

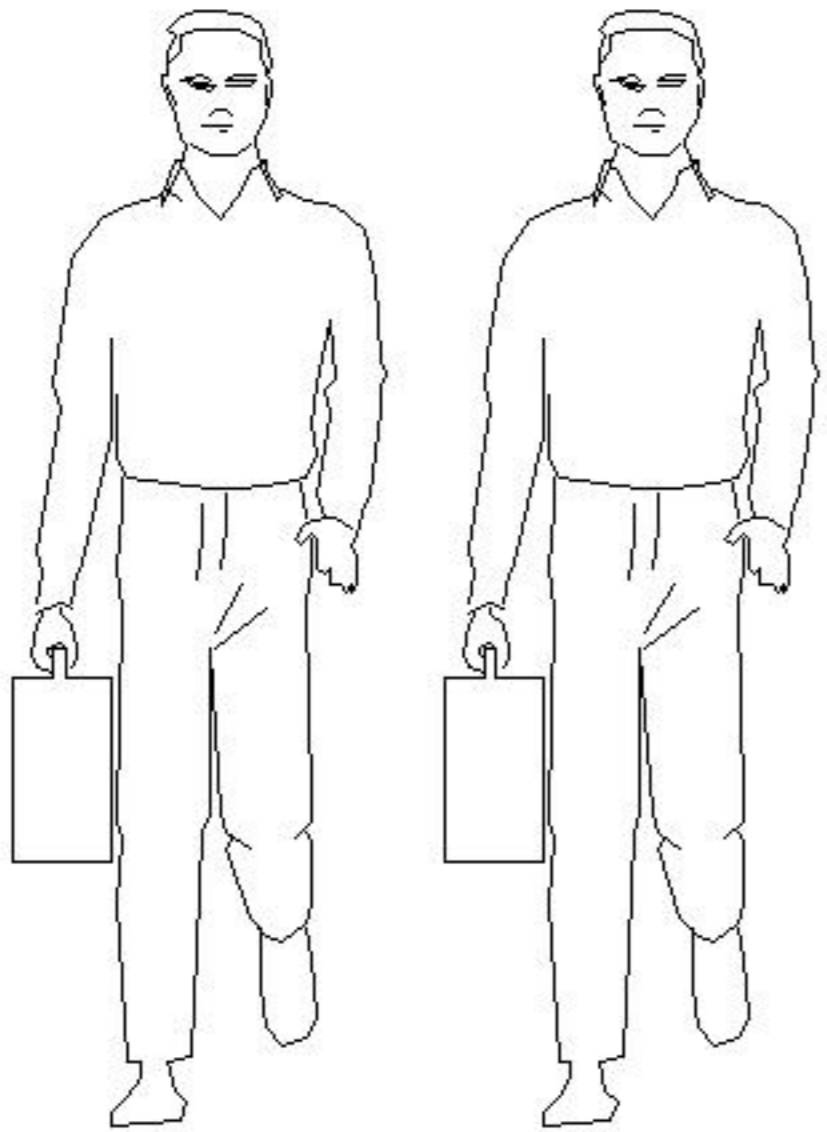
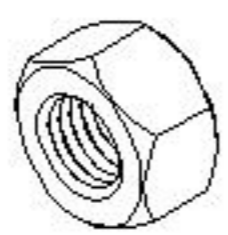

### 安装示意图/Assembly Instruction

产品名称 Model NO.	餐桌
产品型号 Product Model	LH254R7-A 1.6m餐桌
产品规格 Specification	1600*850*753
安装工具 Tool	安装人数 Installer
	

 (A)*8 螺母 M8 nut-(M8)	 (B)*8 双头丝杆 M8*100 Screw rod-(M8*100)	 (C)*8 平垫 $\phi 8*19*1.2$ Flat cushion-( $\phi 8*19*1.2$ )	 (D)*8 弹簧垫 $\phi 8$ Spring pad-( $\phi 8$ )
 (E)*4 自粘棉脚垫 60*60*3 foot pad-(60*60*3)	 (F)*4 双孔螺母 $\phi 12*60*2$ -M8 Double hole nut-( $\phi 12*60*2$ -M8)	 (G)*1 呆扳手 14# wrench-(14#)	

编号NO.	名称Name	规格Specification	数量QTY	材质Material
1	面板组立 Panel assembly	1600*850*120	1	白蜡木 Ash
1-1	面板 panel	1600*850*40	1	白蜡木 Ash
1-2	底框 Surface casing	1506*756*80	1	白蜡木 Ash
1-3	加固条1 Reinforcement Strip 1	86*30*20	4	白蜡木 Ash
1-4	加固条2 Reinforcement Strip 2	86*40*20	6	白蜡木 Ash
2	脚 foot	710*115*115	4	白蜡木 Ash

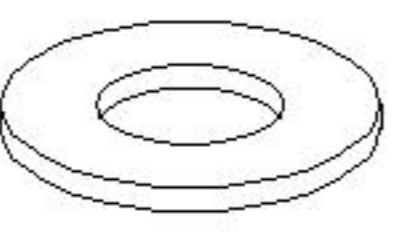
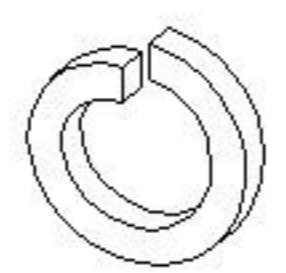
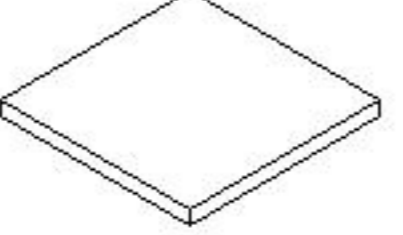
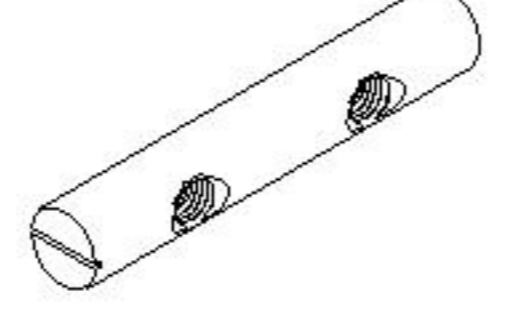
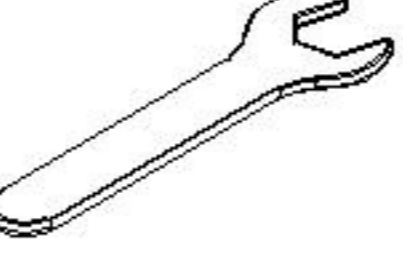
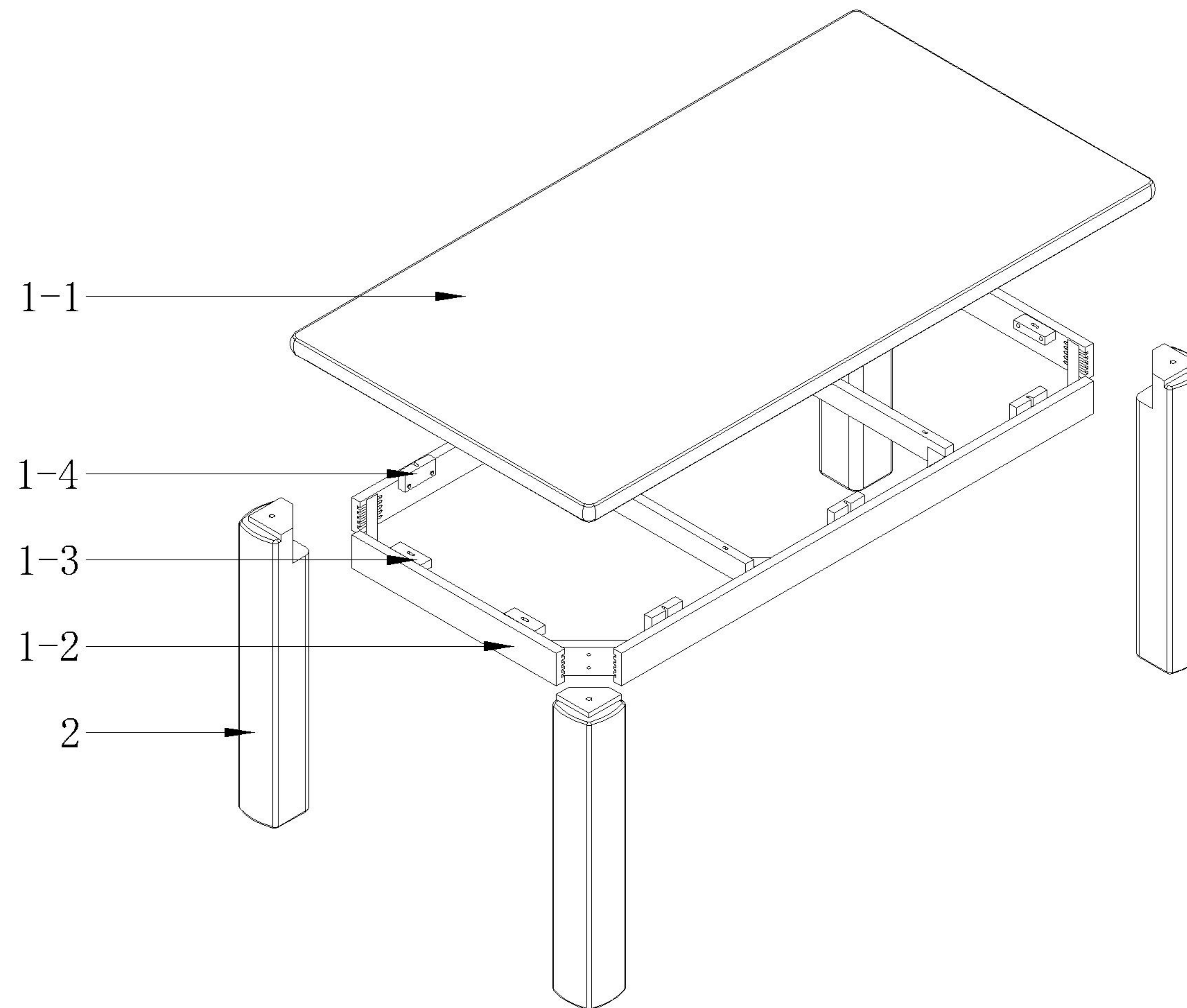
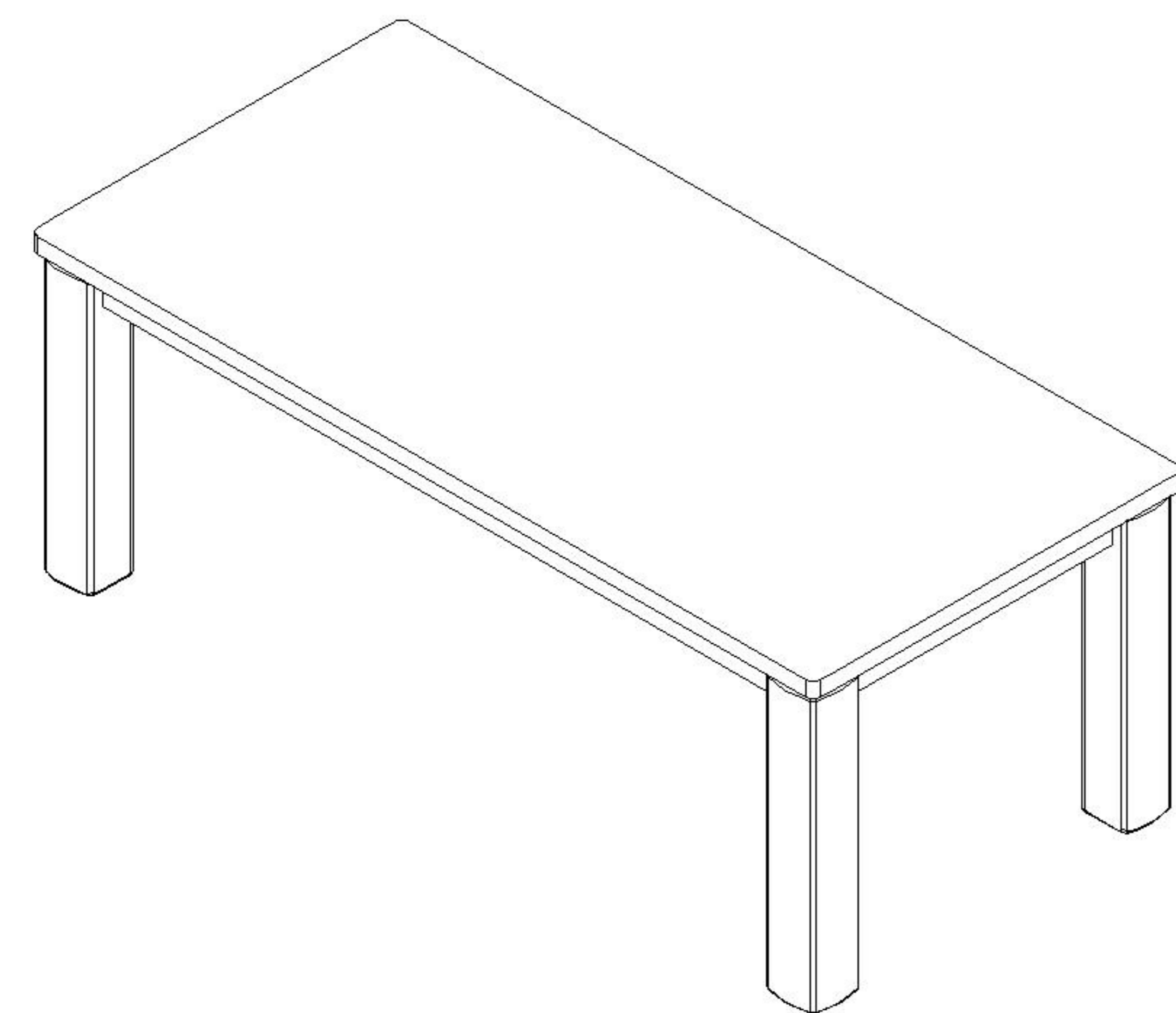

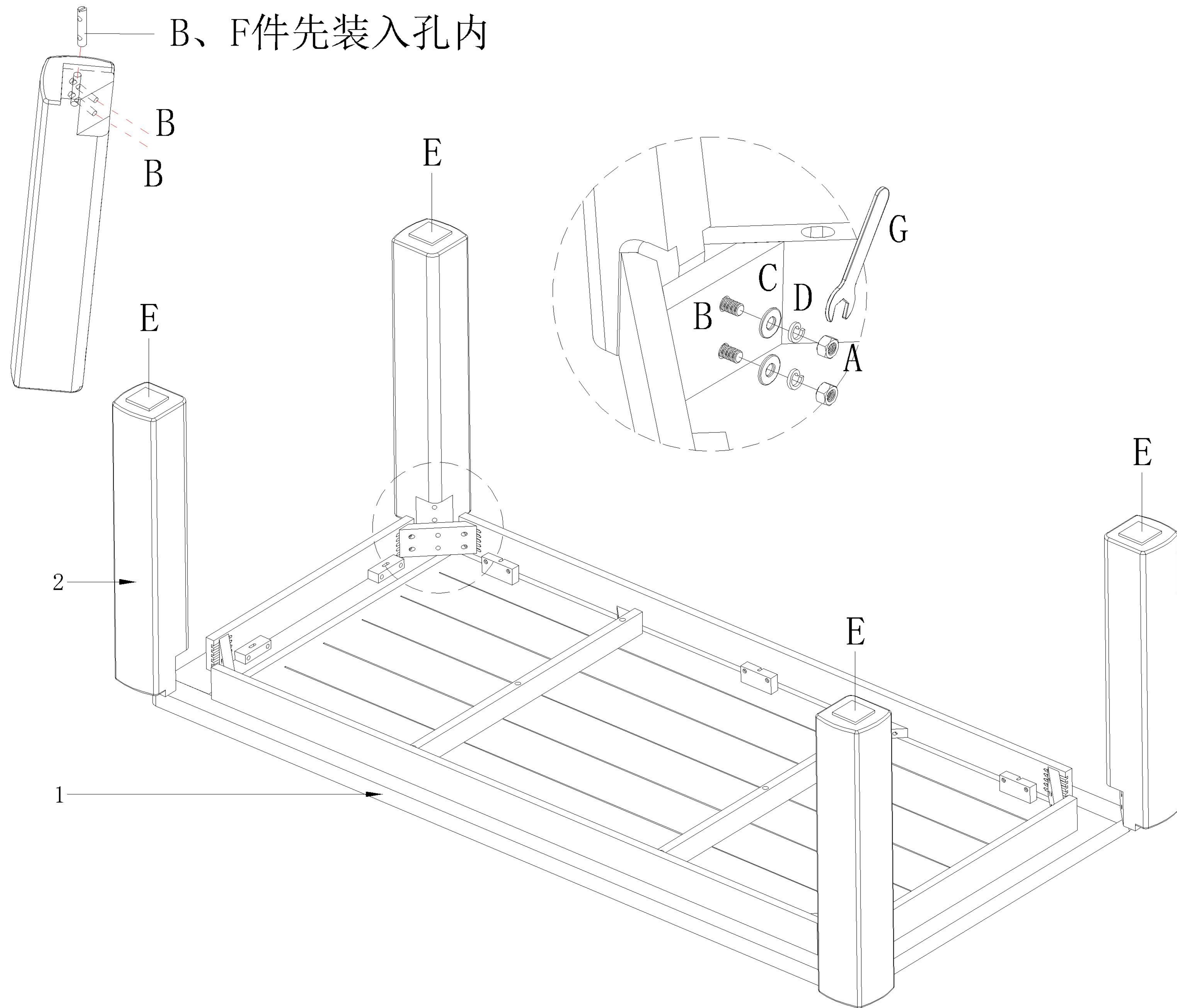

### 安装示意图/Assembly Instruction

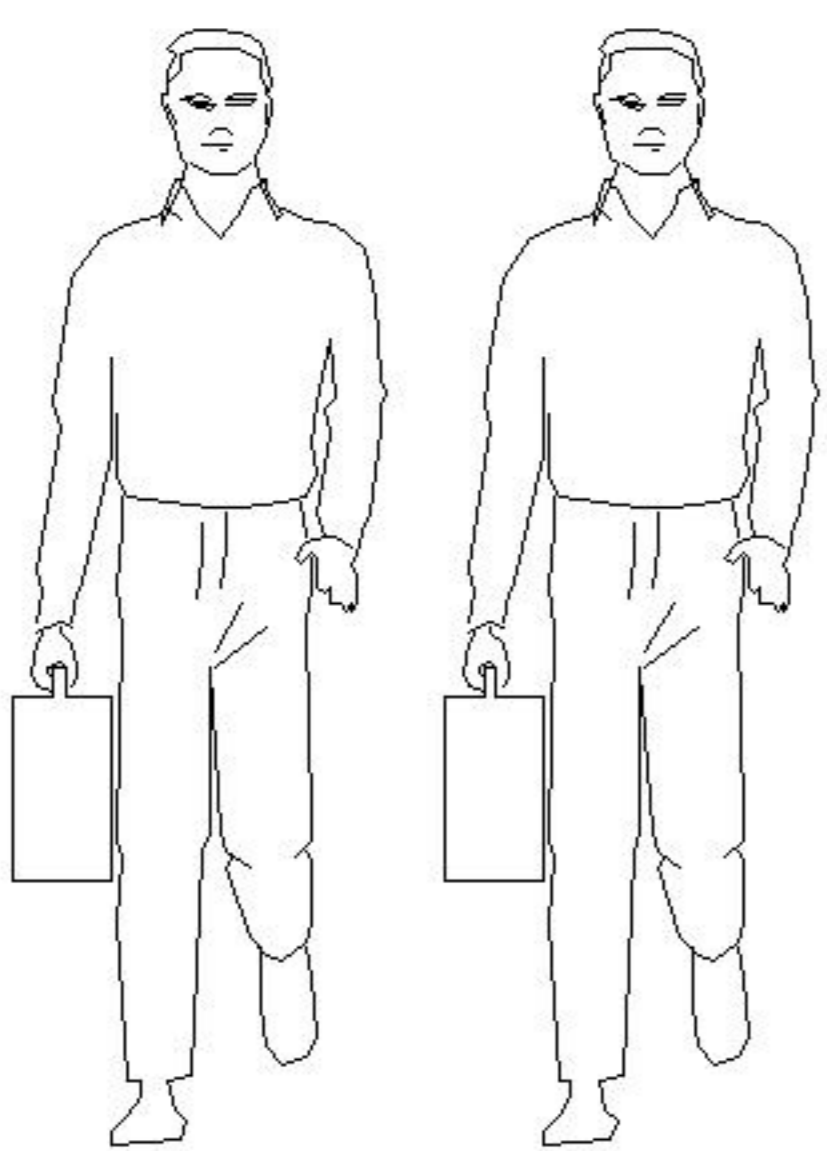
产品名称 Model NO.	餐桌
产品型号 Product Model	LH254R7-A 1.8m餐桌
产品规格 Specification	1800*900*753
安装工具 Tool	安装人数 Installer
	

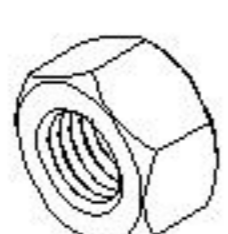
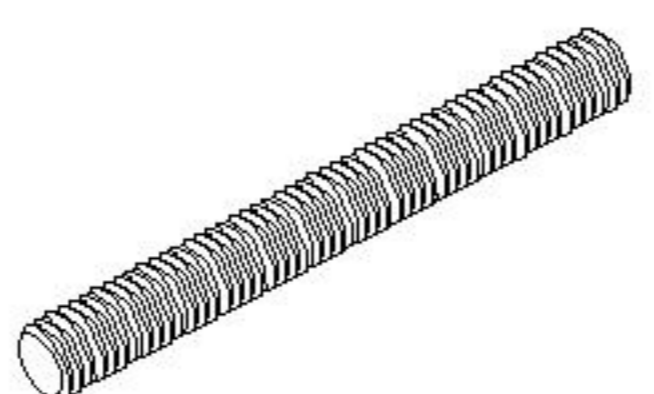
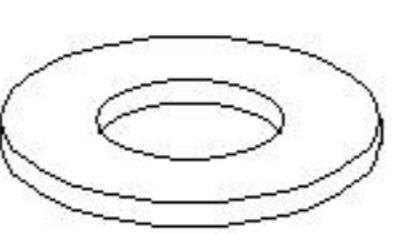
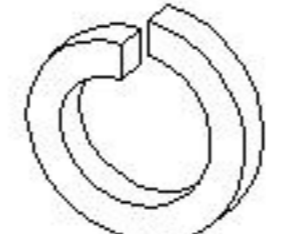
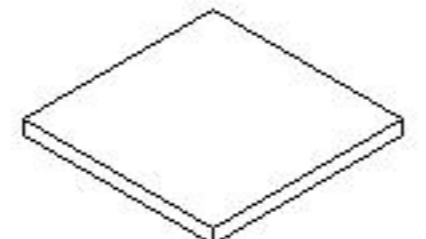
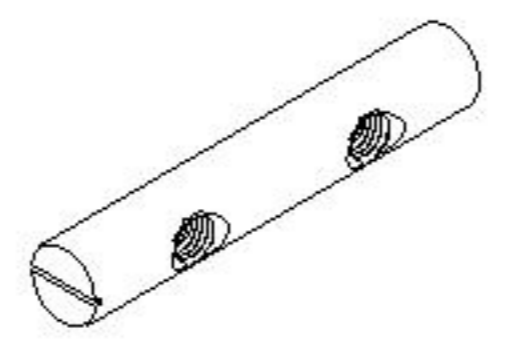
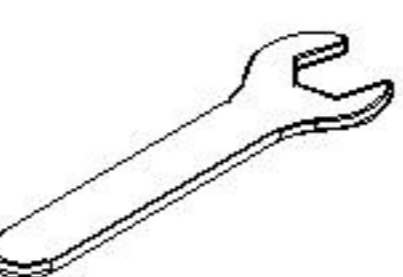
 (A)*8 螺母 M8 nut-(M8)	 (B)*8 双头丝杆 M8*100 Screw rod-(M8*100)	 (C)*8 平垫 $\phi 8*19*1.2$ Flat cushion-( $\phi 8*19*1.2$ )	 (D)*8 弹簧垫 $\phi 8$ Spring pad-( $\phi 8$ )
 (E)*4 自粘棉脚垫 60*60*3 foot pad-(60*60*3)	 (F)*4 双孔螺母 $\phi 12*60*2-M8$ Double hole nut-( $\phi 12*60*2-M8$ )	 (G)*1 呆扳手 14# wrench-(14#)	

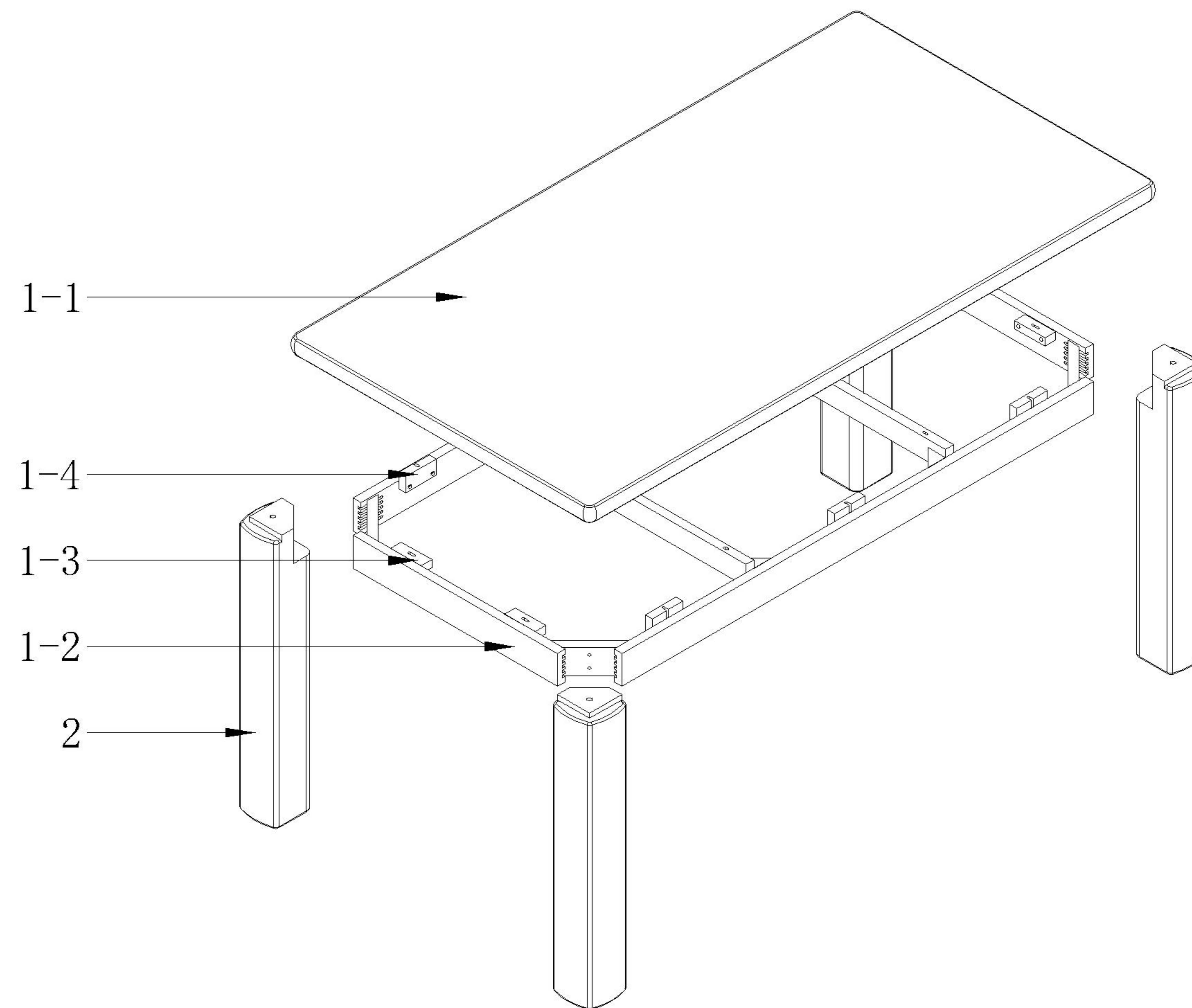
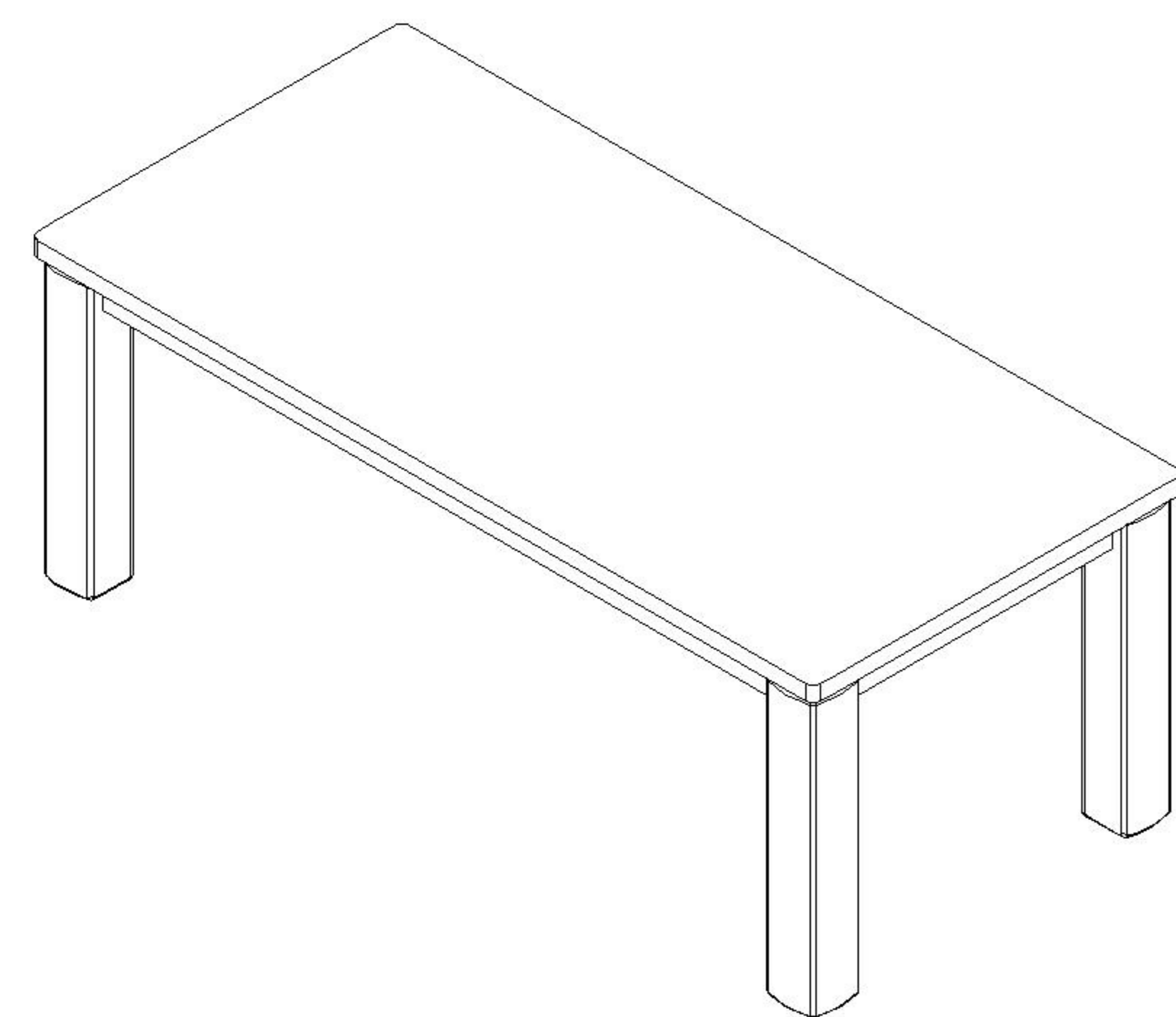

编号NO.	名称Name	规格Specification	数量QTY	材质Material
1	面板组立 Panel assembly	1800*900*120	1	白蜡木 Ash
1-1	面板 panel	1800*900*40	1	白蜡木 Ash
1-2	底框 Surface casing	1706*806*80	1	白蜡木 Ash
1-3	加固条1 Reinforcement Strip 1	86*30*20	4	白蜡木 Ash
1-4	加固条2 Reinforcement Strip 2	86*40*20	6	白蜡木 Ash
2	脚 foot	710*130*130	4	白蜡木 Ash

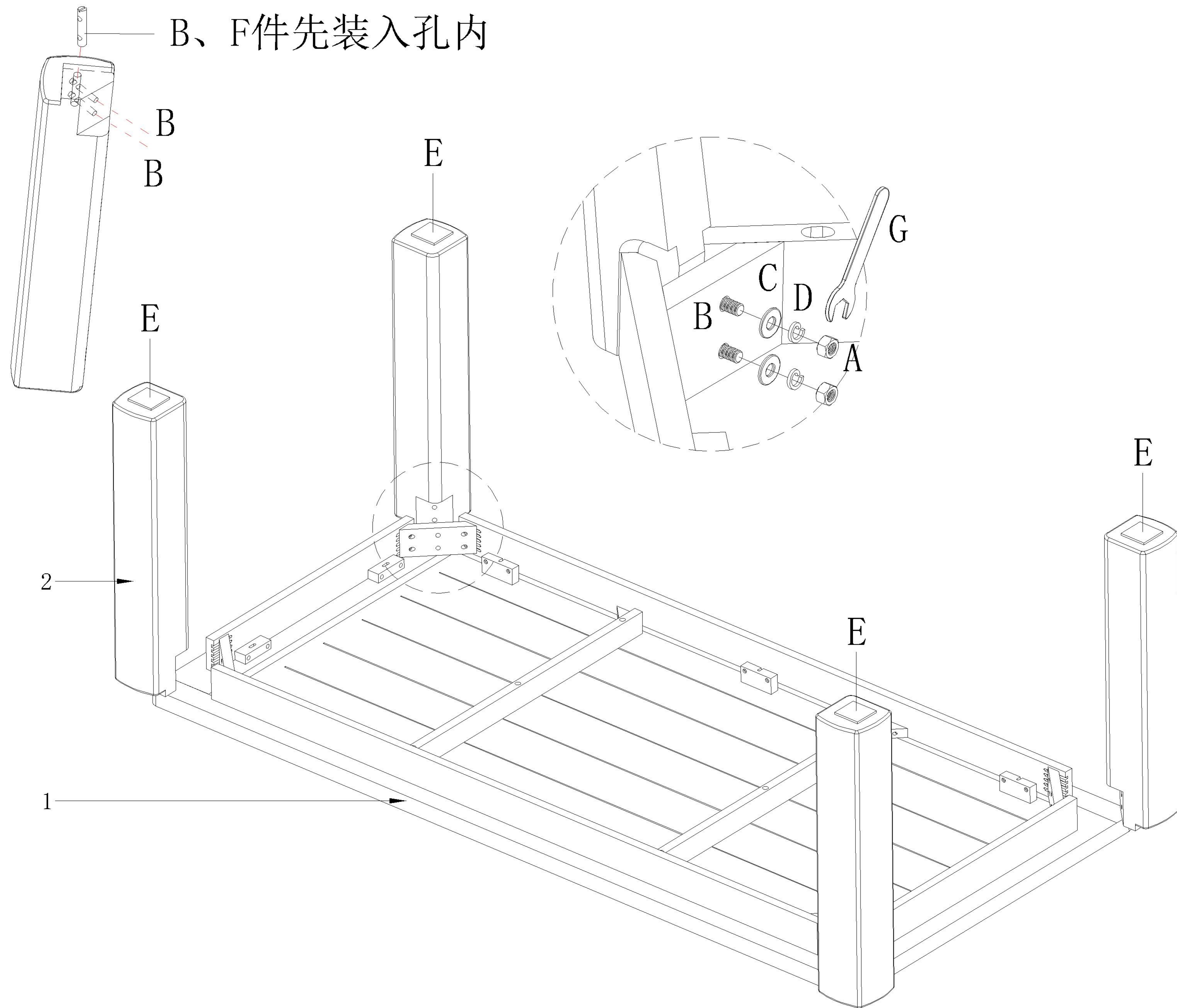

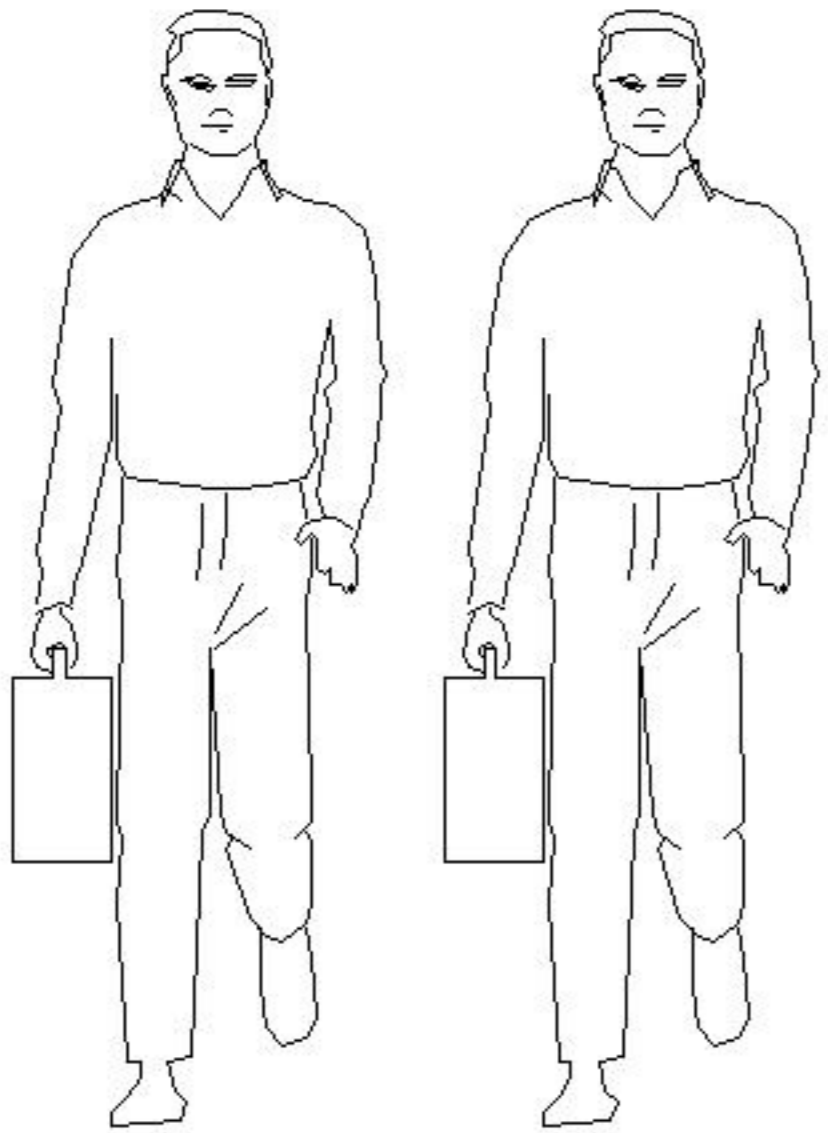

### 安装示意图/Assembly Instruction

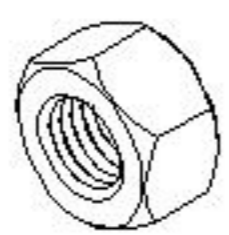
产品名称 Model NO.	餐桌
产品型号 Product Model	LH254R7-A 2.0m餐桌
产品规格 Specification	2000*950*753
安装工具 Tool	安装人数 Installer
	

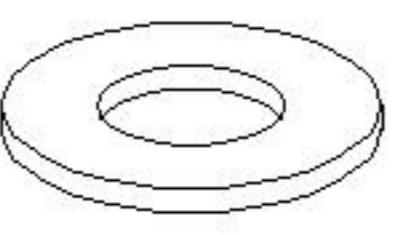
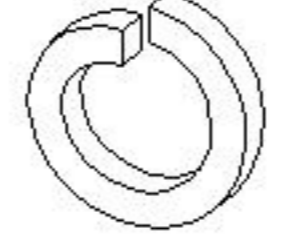
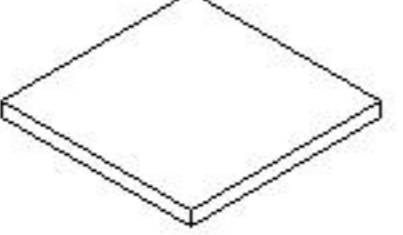
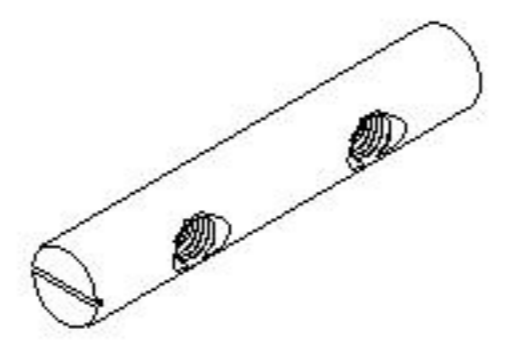
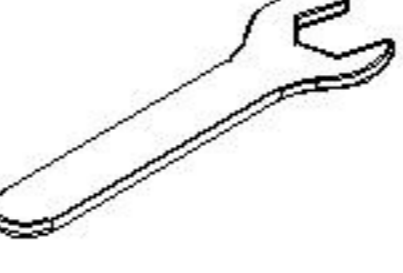
 (A)*8 螺母 M8 nut-(M8)	 (B)*8 双头丝杆 M8*100 Screw rod-(M8*100)	 (C)*8 平垫 $\phi 8*19*1.2$ Flat cushion-( $\phi 8*19*1.2$ )	 (D)*8 弹簧垫 $\phi 8$ Spring pad-( $\phi 8$ )
 (E)*4 自粘棉脚垫 60*60*3 foot pad-(60*60*3)	 (F)*4 双孔螺母 $\phi 12*60*2-M8$ Double hole nut-( $\phi 12*60*2-M8$ )	 (G)*1 呆扳手 14# wrench-(14#)	

编号NO.	名称Name	规格Specification	数量QTY	材质Material
1	面板组立 Panel assembly	2000*950*120	1	白蜡木 Ash
1-1	面板 panel	2000*950*40	1	白蜡木 Ash
1-2	面框 Surface casing	1906*856*80	1	白蜡木 Ash
1-3	加固条1 Reinforcement Strip 1	86*30*20	4	白蜡木 Ash
1-4	加固条2 Reinforcement Strip 2	86*40*20	6	白蜡木 Ash
2	脚 foot	710*130*130	4	白蜡木 Ash

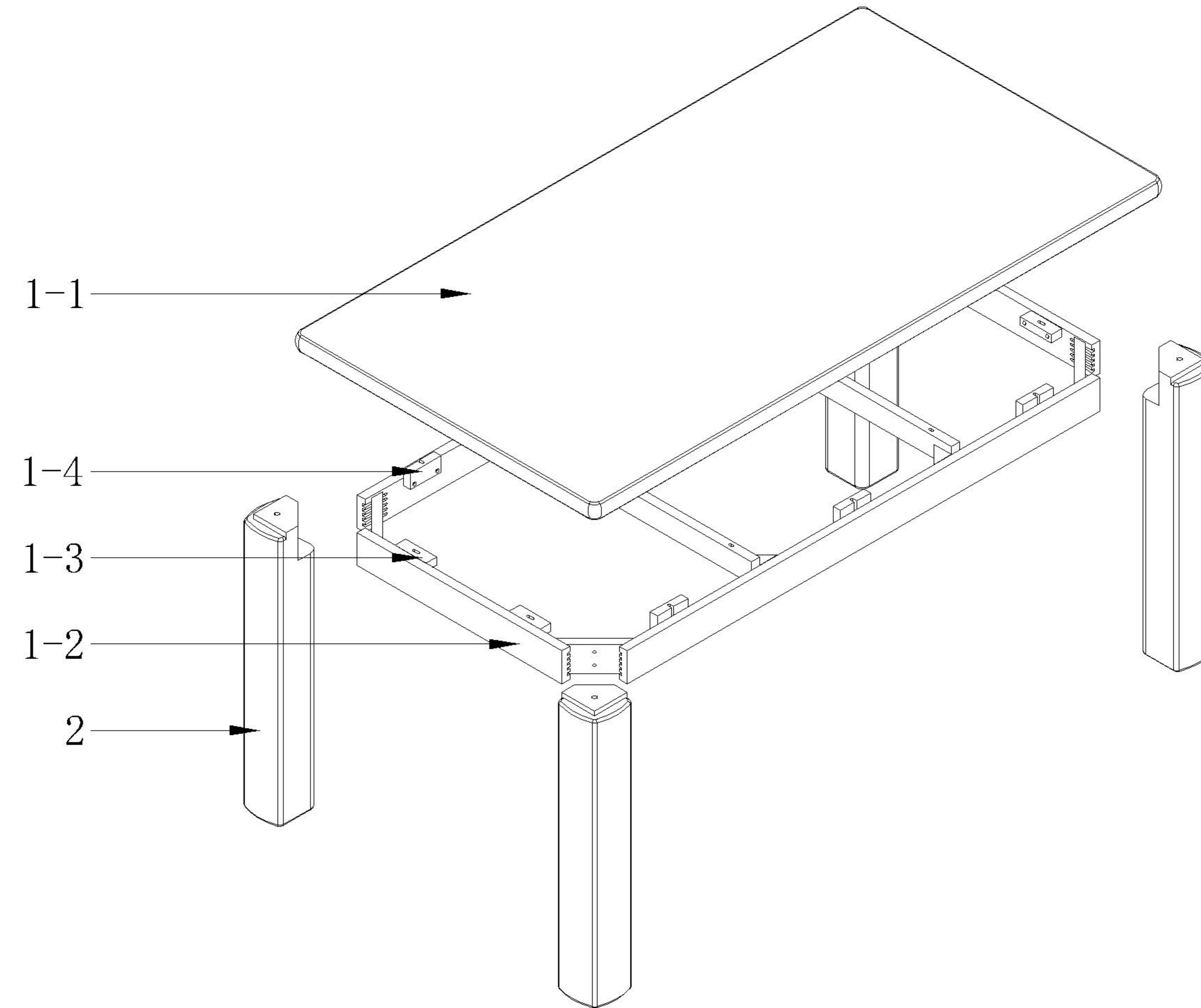
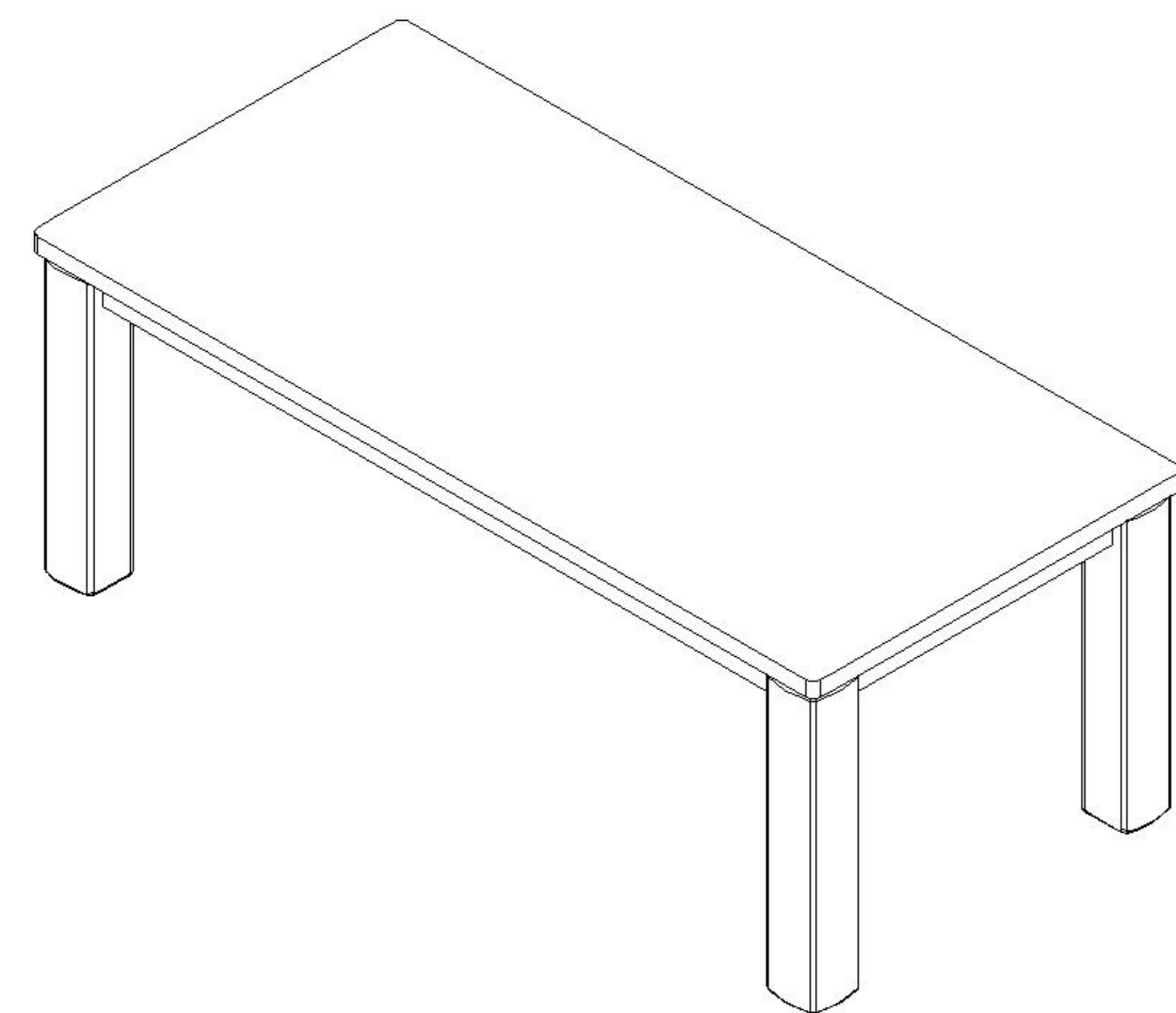

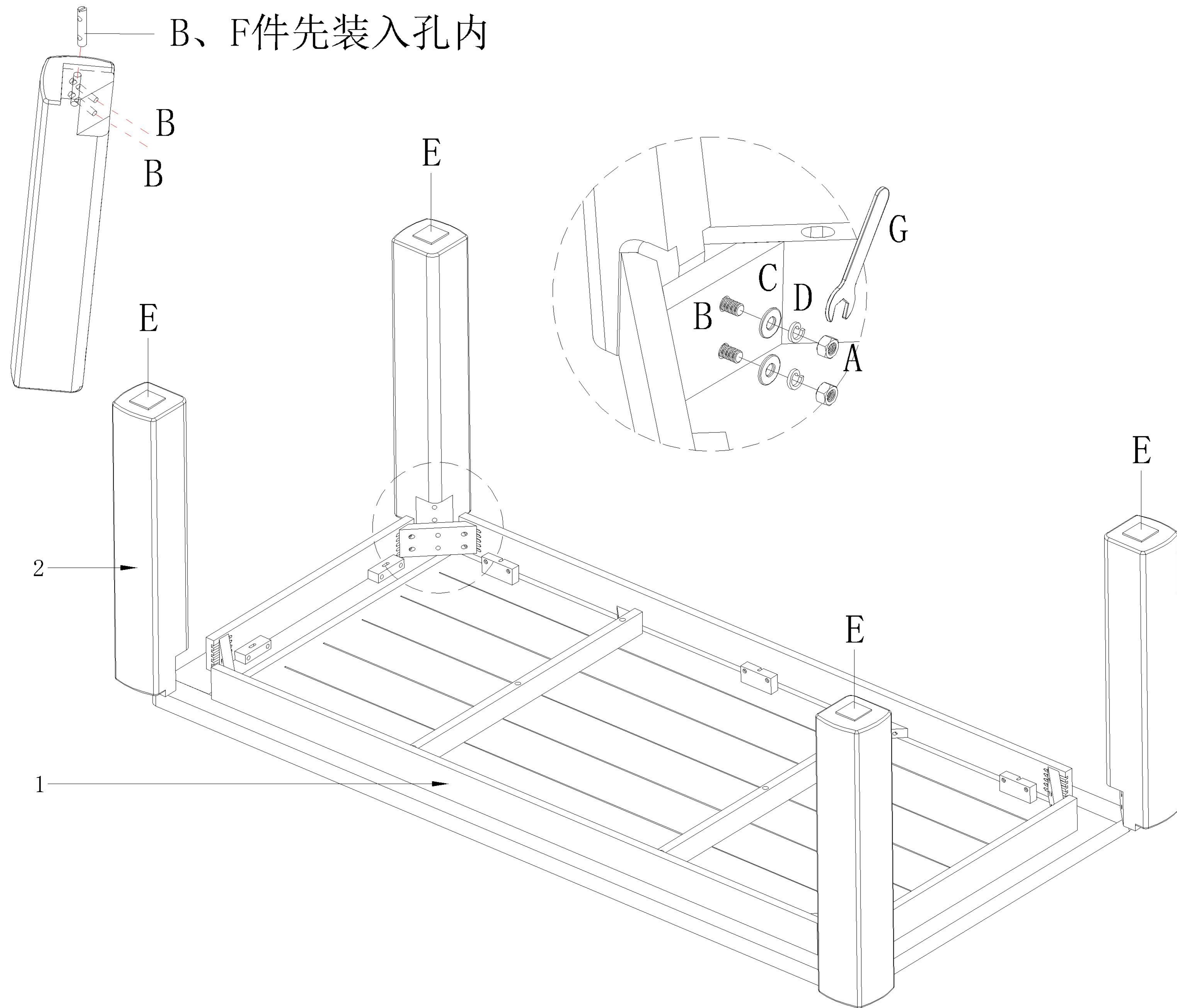



# LINSY 林氏家居

## 五金表/Hardware list

## 部件表/Parts List

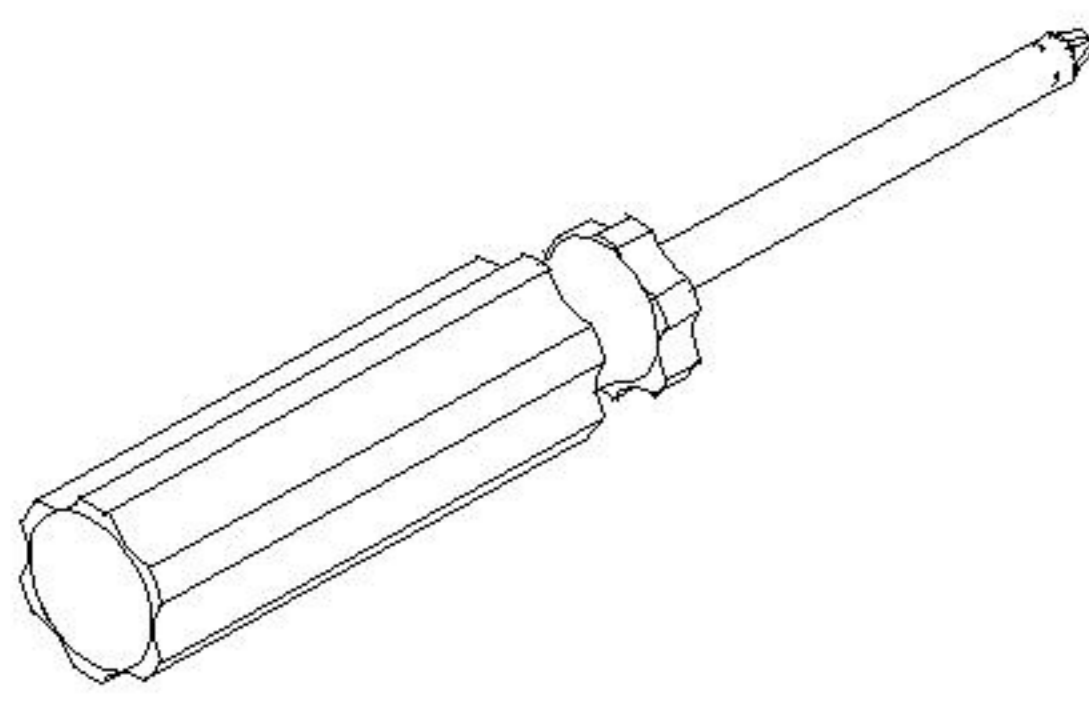
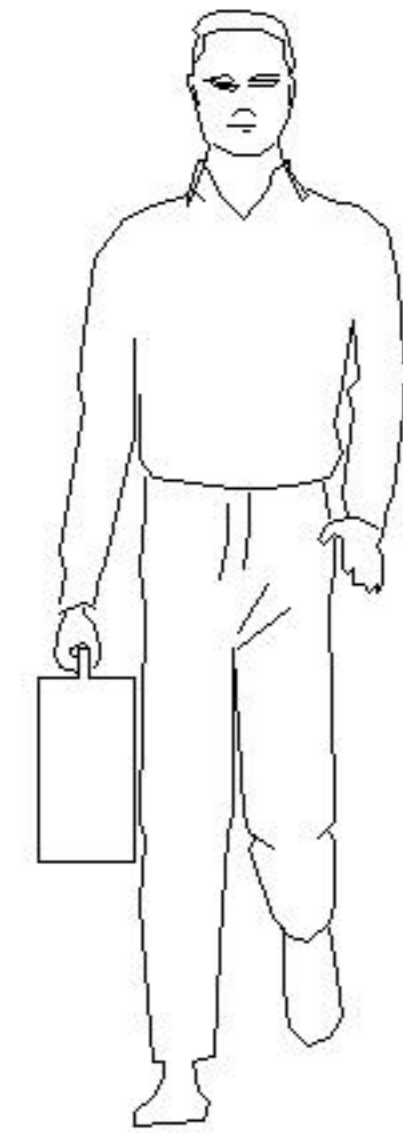
### 安装示意图/Assembly Instruction

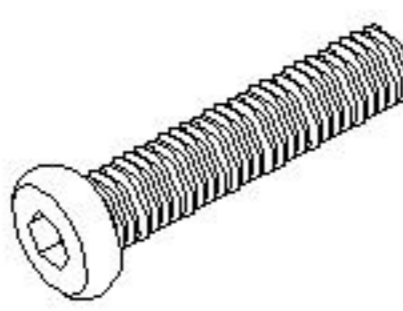
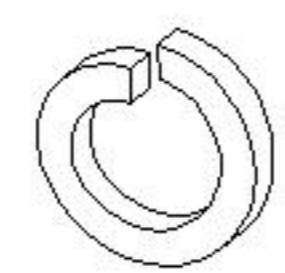
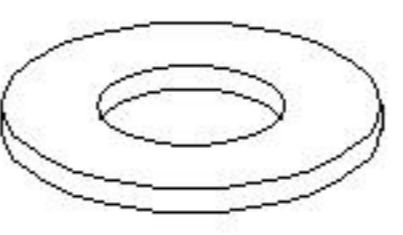
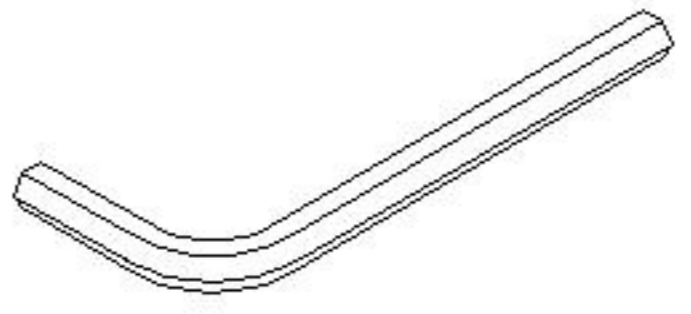
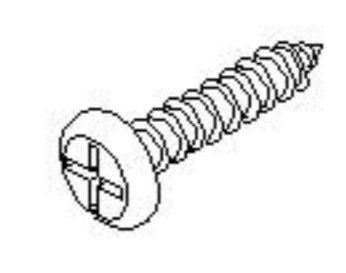
产品名称 Model NO.	餐椅
产品型号 Product Model	LH254S1-A1
产品规格 Specification	430*473*800
安装工具 Tool	安装人数 Installer
	

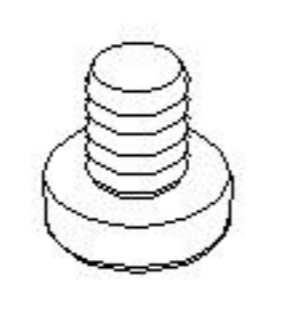
 (A)*8 内六角丝杆 M8*70 Screw rod-(M8*70)	 (B)*8 弹簧垫 φ8 Spring pad-(φ8)	 (C)*8 平垫 φ8*16*1.2 Flat cushion-(φ8*16*1.2)	 (D)*1 六角扳手 5# Wrench-(5mm)
 (E)*10 大扁头自攻钉 M4*16 Self tapping silk-(M4*16)	 (F)*5 角铁 25*25*18*2 angle iron-(25*25*18*2)	 (G)*4 透明橡胶脚垫 φ16*φ8.8*16 door mat-(φ16*φ8.8*16)	

编号NO.	名称Name	规格 Specification	数量QTY	材质Material
1	靠背 backrest	800*430*88	1	白蜡木 Ash
1.1	背弯 Root	430*140*20	1	白蜡木 Ash
1.2	后脚架 Rear tripod	765*420*35	1	白蜡木 Ash
2	坐框 Sitting frame	370*382*60	1	白蜡木 Ash
3	前脚 Forefoot	φ35*415	2	白蜡木 Ash
4	软包坐板 Seat plate	425*435*40	1	多层板+海绵+皮料 Plywood+Sponge-Artificial leather

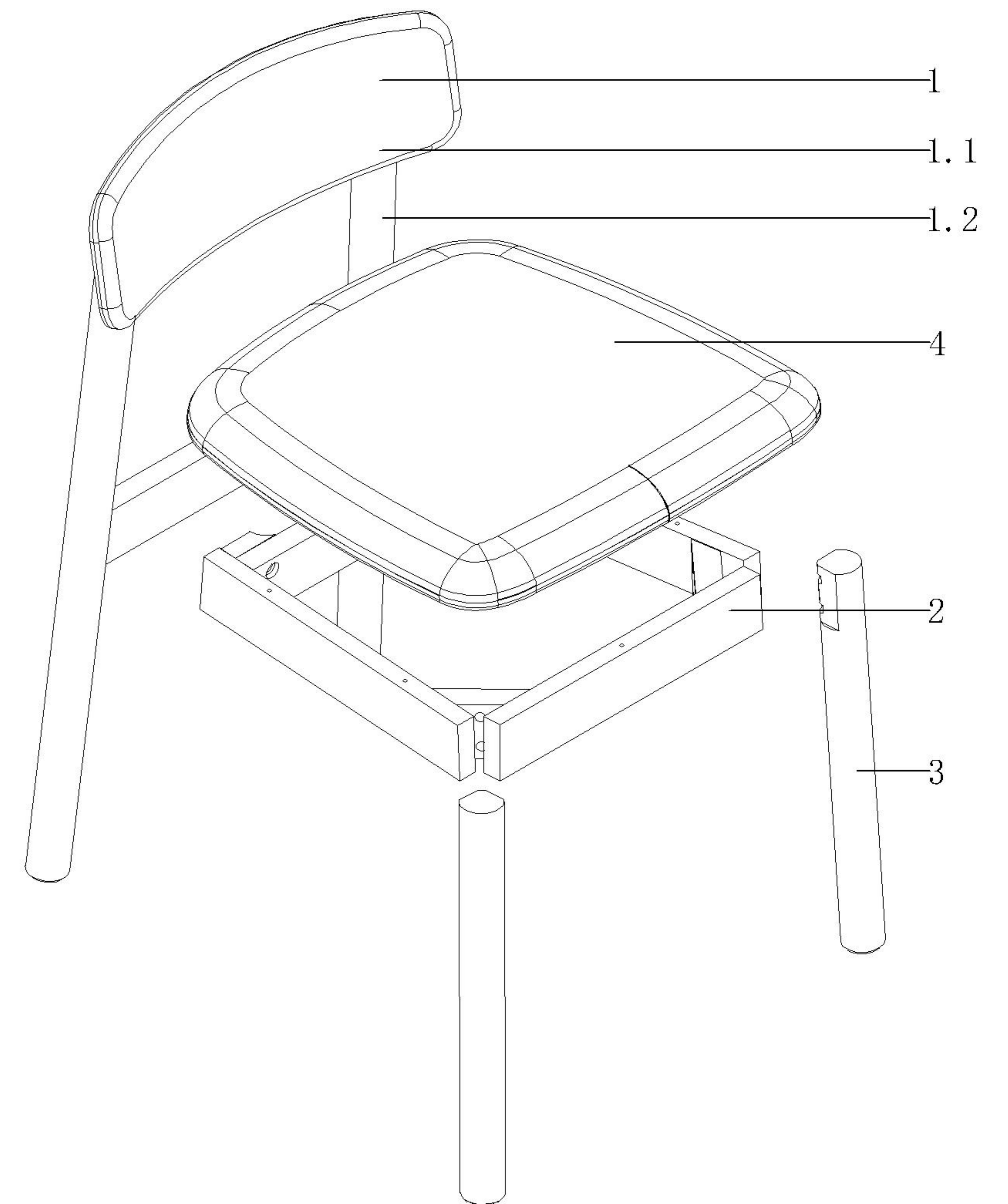
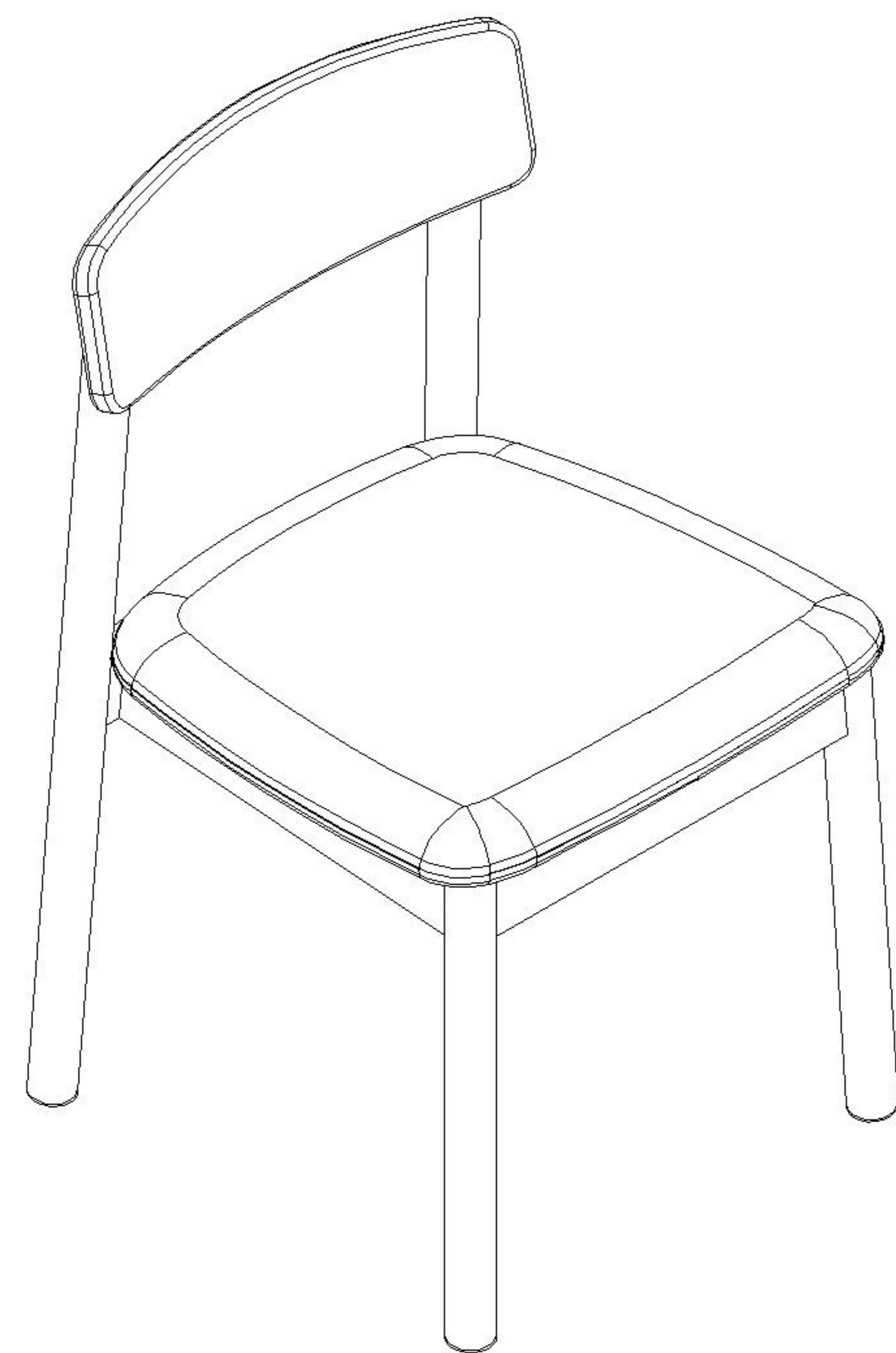

LH254S1-A1

安装方法/  
Installation method

- (A)\*4
- (B)\*4
- (C)\*4
- (D)\*1

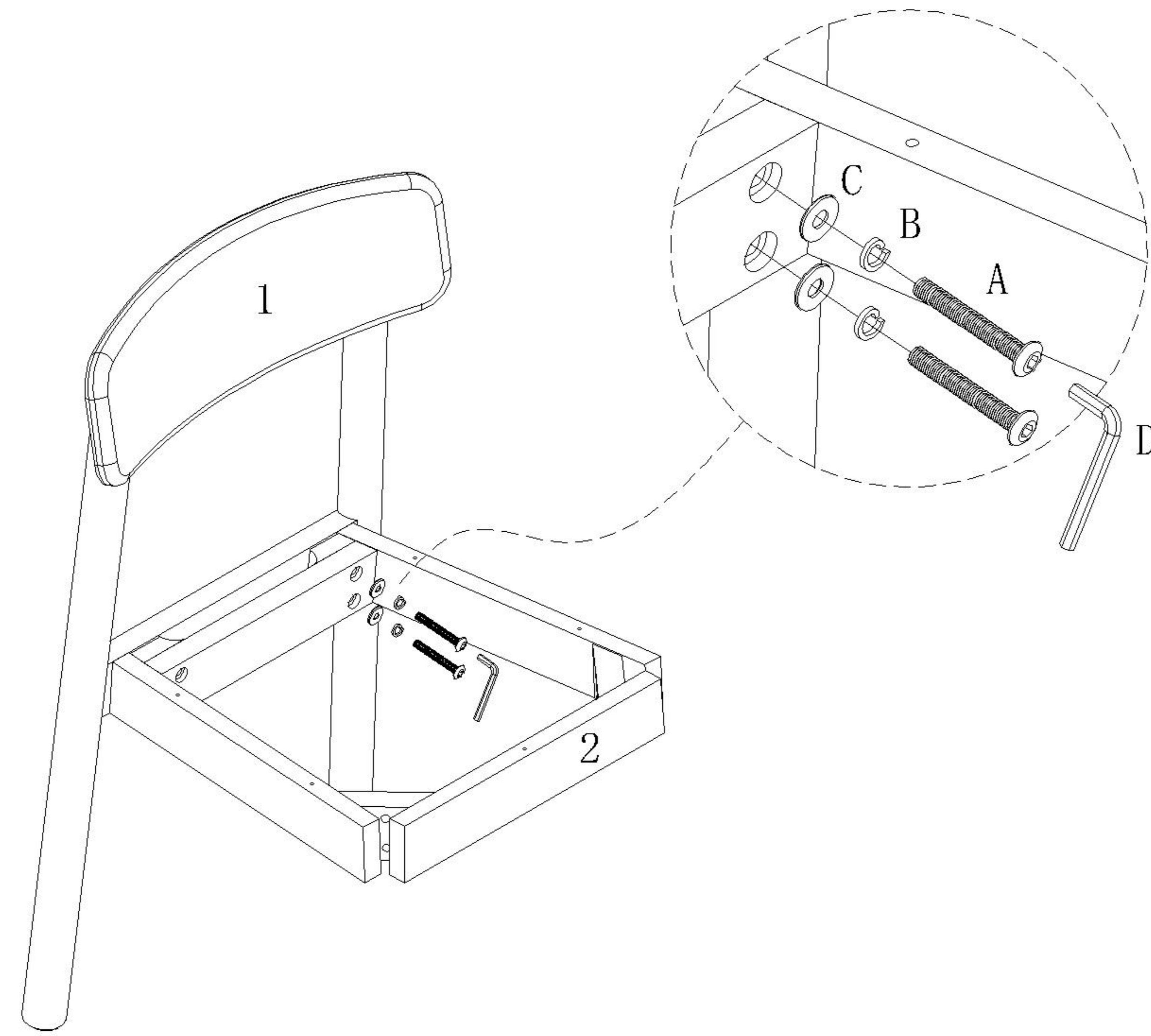

- (A)\*1
- (B)\*4
- (C)\*4
- (D)\*4

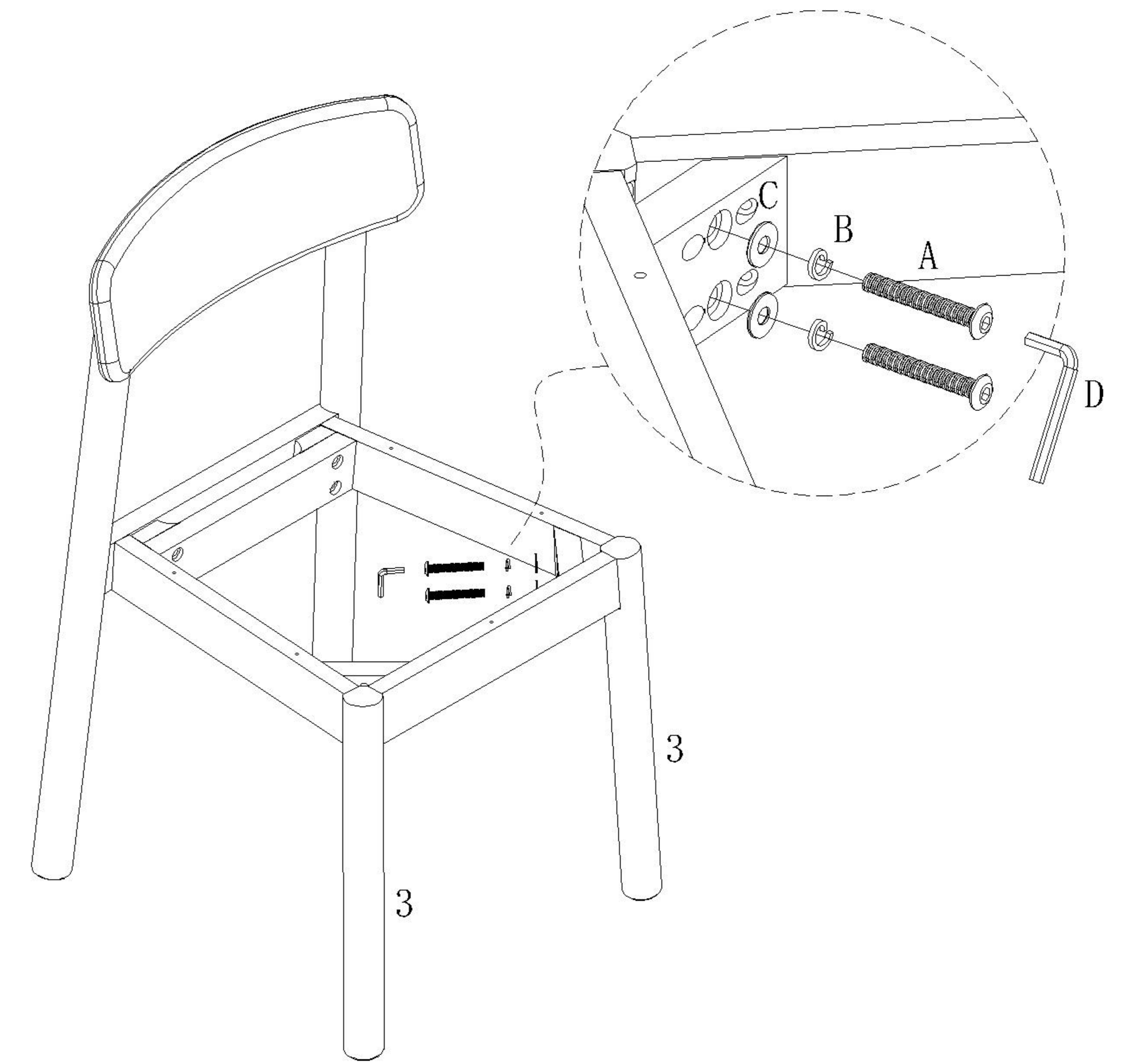

- (E)\*5
- (F)\*5

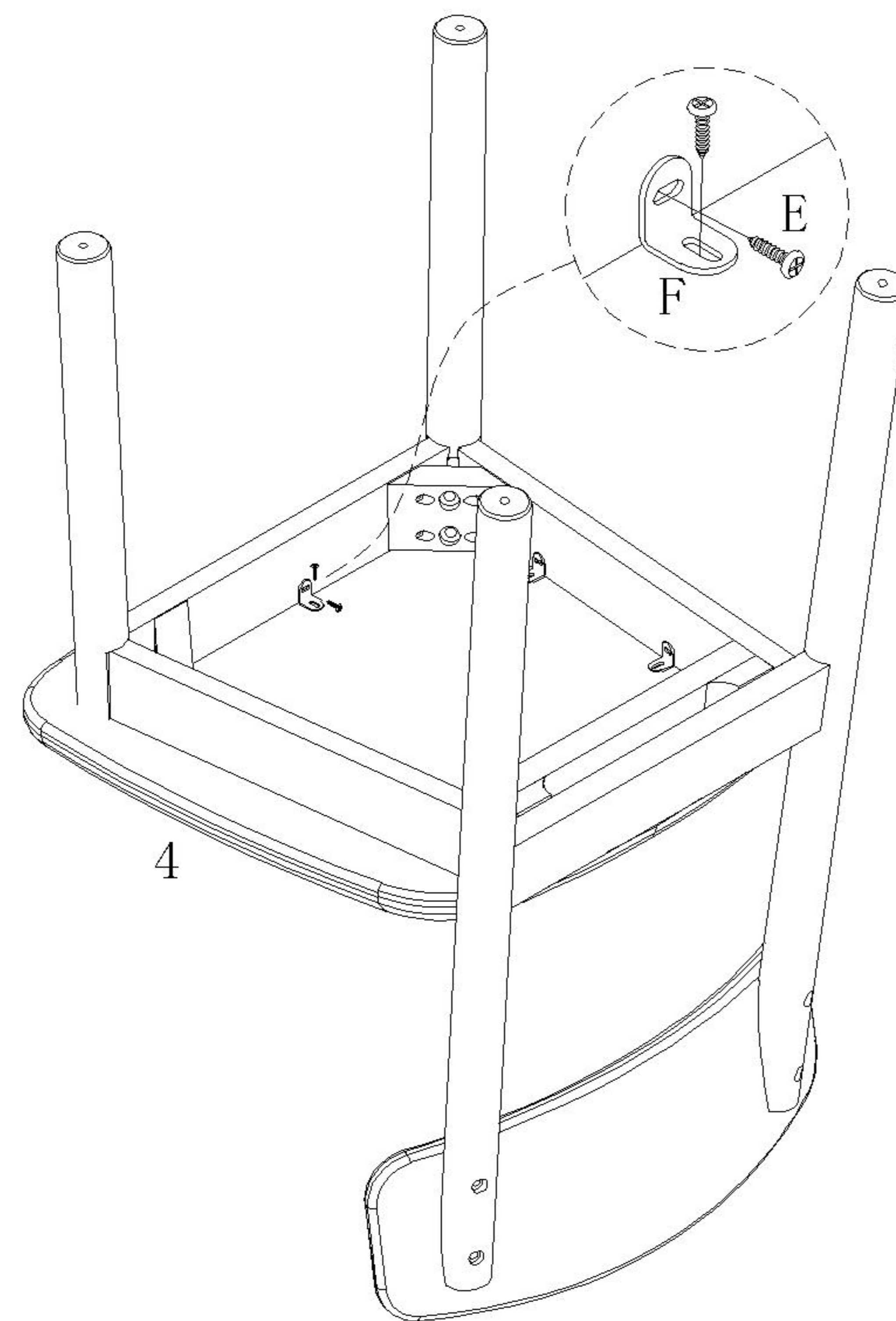

- (G)\*4

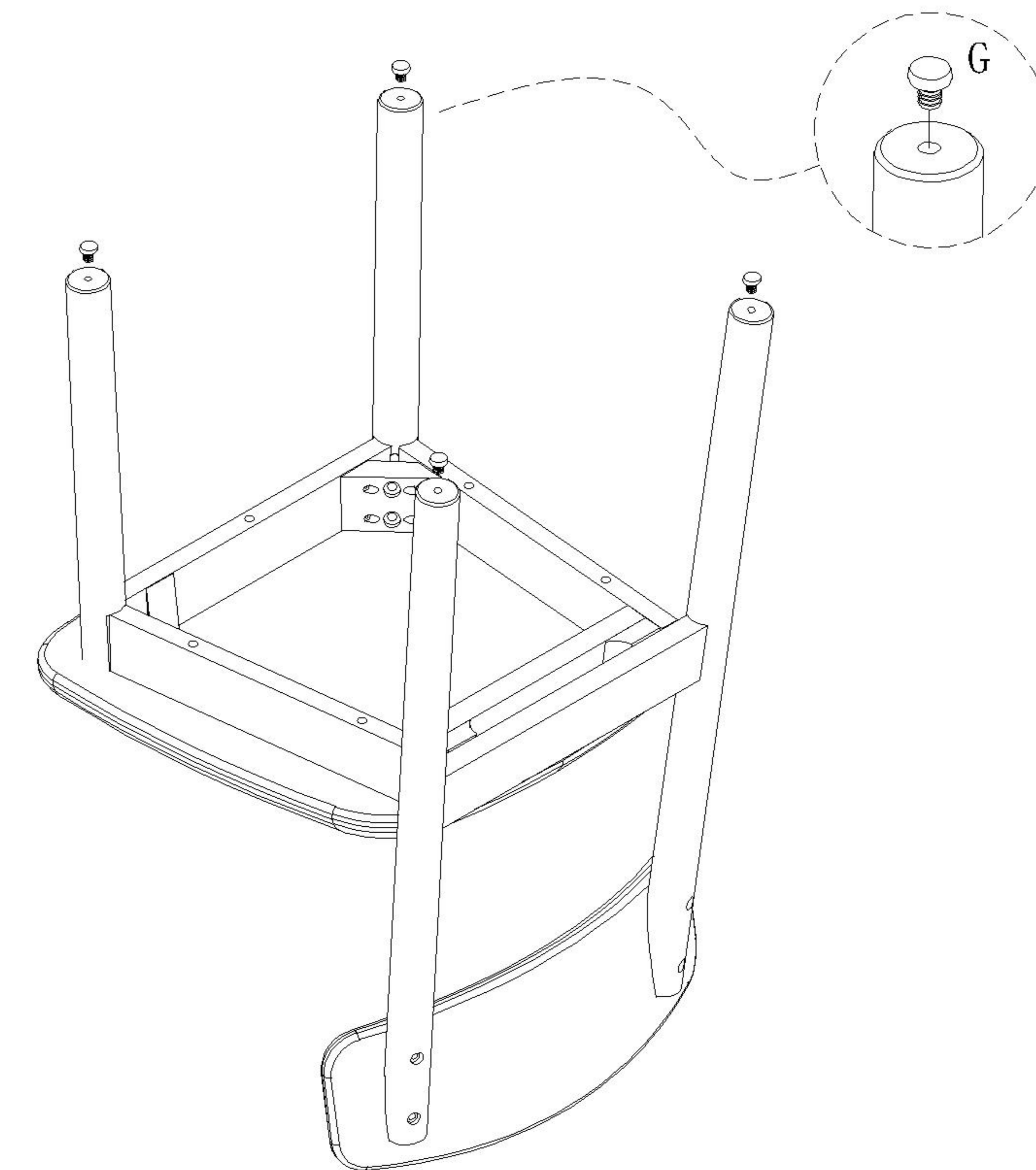



# LINSY 林氏家居

## 五金表/Hardware list

## 部件表/Parts List

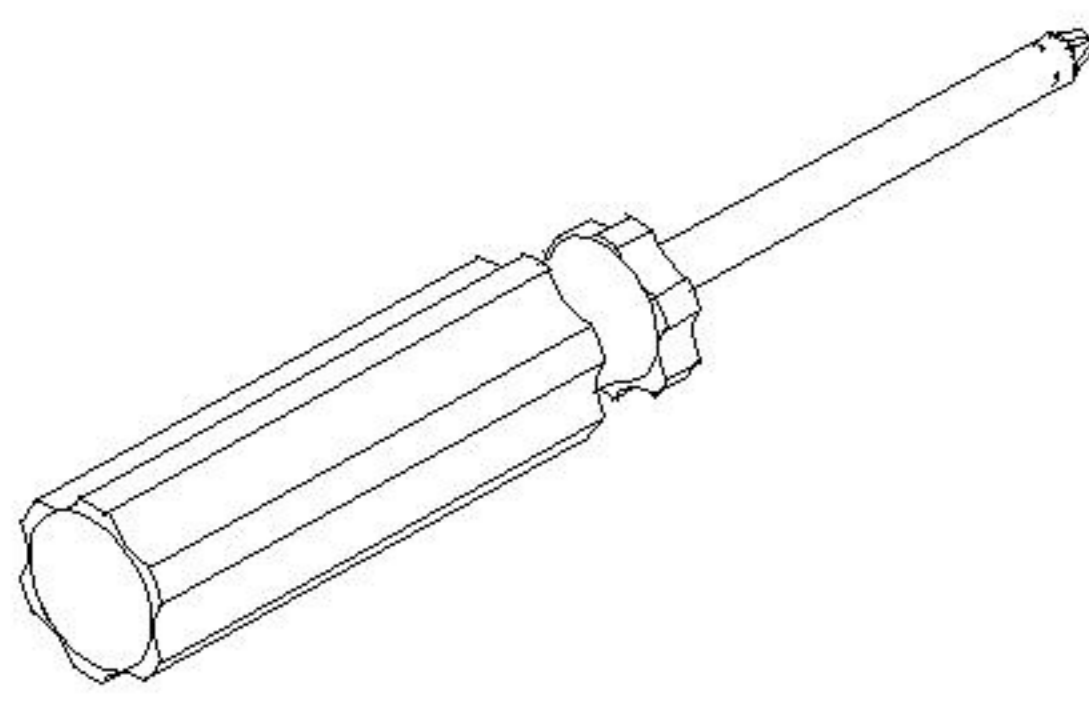
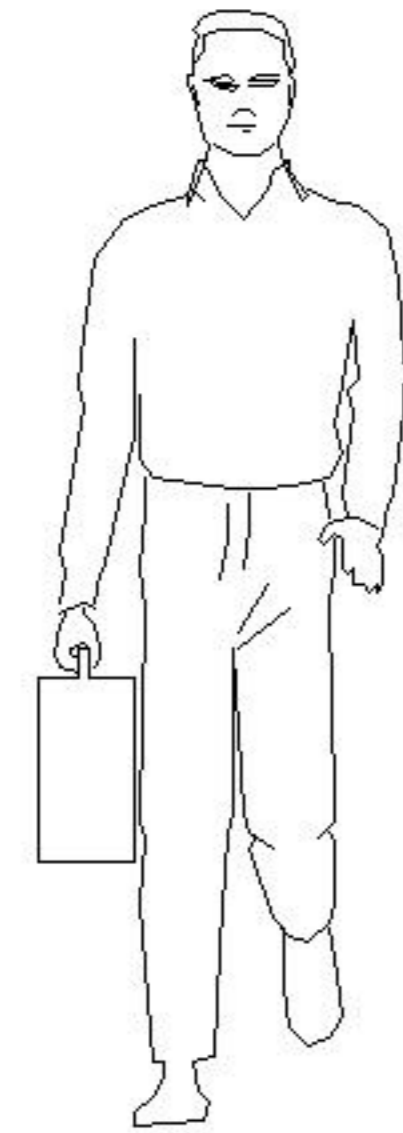
### 安装示意图/Assembly Instruction

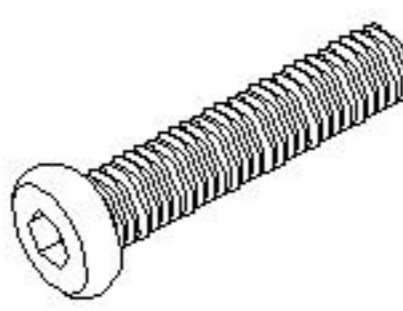
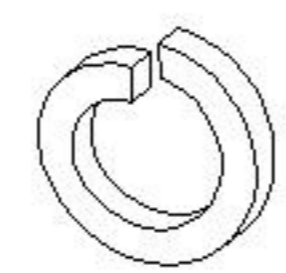
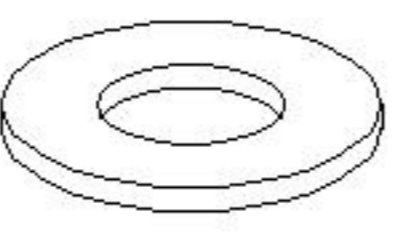
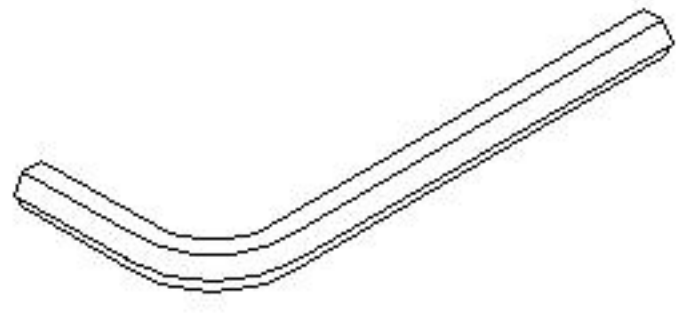
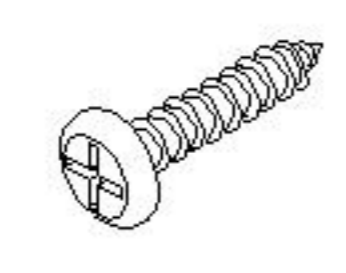
产品名称 Model NO.	餐椅
产品型号 Product Model	LH254S2-A1
产品规格 Specification	430*473*800
安装工具 Tool	安装人数 Installer
	

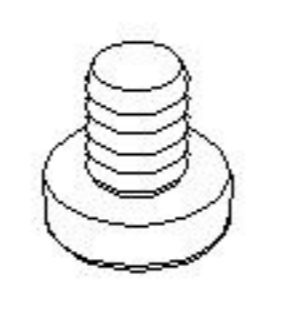

 (A)*8 内六角丝杆 M8*70 Screw rod-(M8*70)	 (B)*8 弹簧垫 φ8 Spring pad-(φ8)	 (C)*8 平垫 φ8*16*1.2 Flat cushion-(φ8*16*1.2)	 (D)*1 六角扳手 5# Wrench-(5mm)
 (E)*10 大扁头自攻钉 M4*16 Self tapping silk-(M4*16)	 (F)*5 角铁 25*25*18*2 angle iron-(25*25*18*2)	 (G)*4 透明橡胶脚垫 φ16*φ8.8*16 door mat-(φ16*φ8.8*16)	

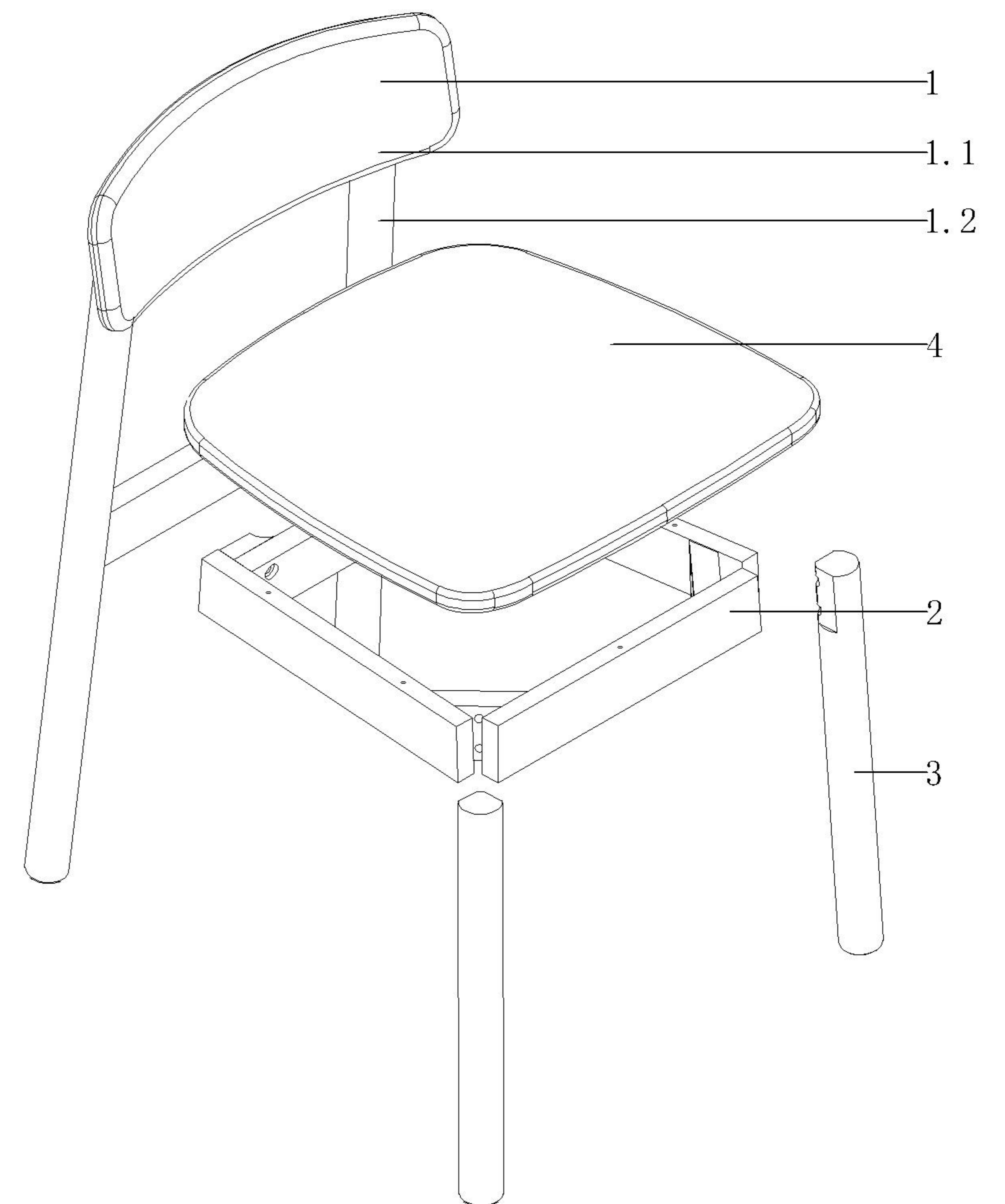
编号NO.	名称Name	规格 Specification	数量QTY	材质Material
1	靠背 backrest	800*430*88	1	白蜡木 Ash
1.1	背弯 Root	430*140*20	1	白蜡木 Ash
1.2	后脚架 Rear tripod	765*420*35	1	白蜡木 Ash
2	坐框 Sitting frame	370*382*60	1	白蜡木 Ash
3	前脚 Forefoot	φ35*415	2	白蜡木 Ash
4	坐板 Seat plate	425*435*20	1	白蜡木 Ash



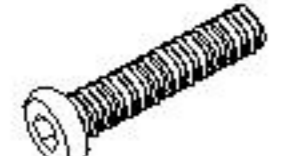
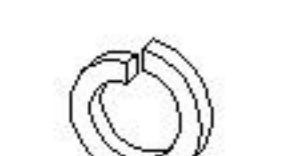
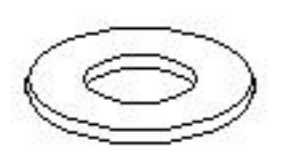

LH254S2-A1

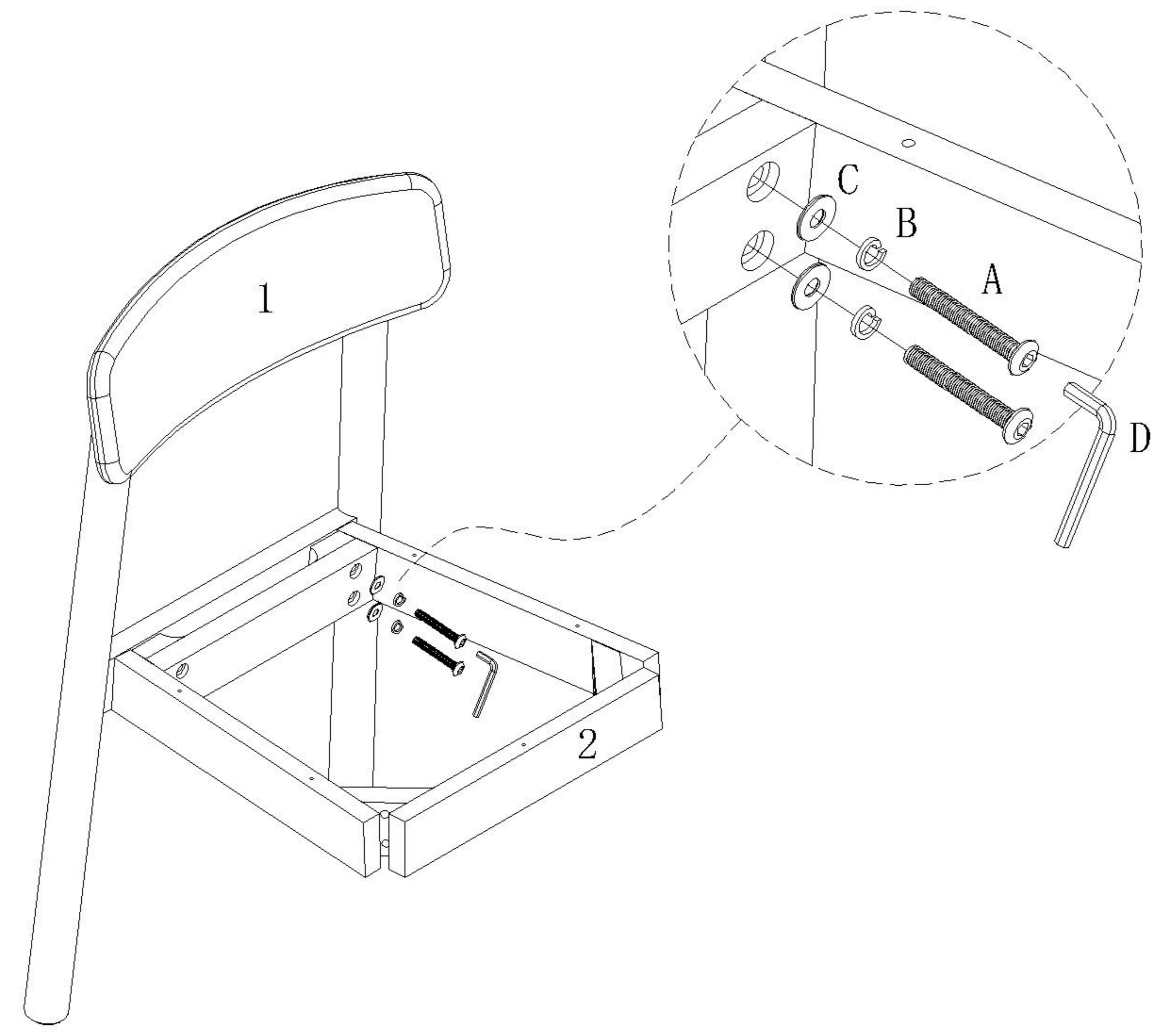

安装方法/  
Installation method

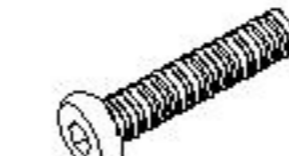
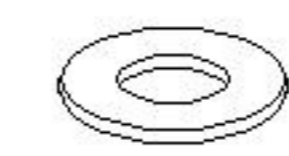
-  (A)\*4
-  (B)\*4
-  (C)\*4
-  (D)\*1

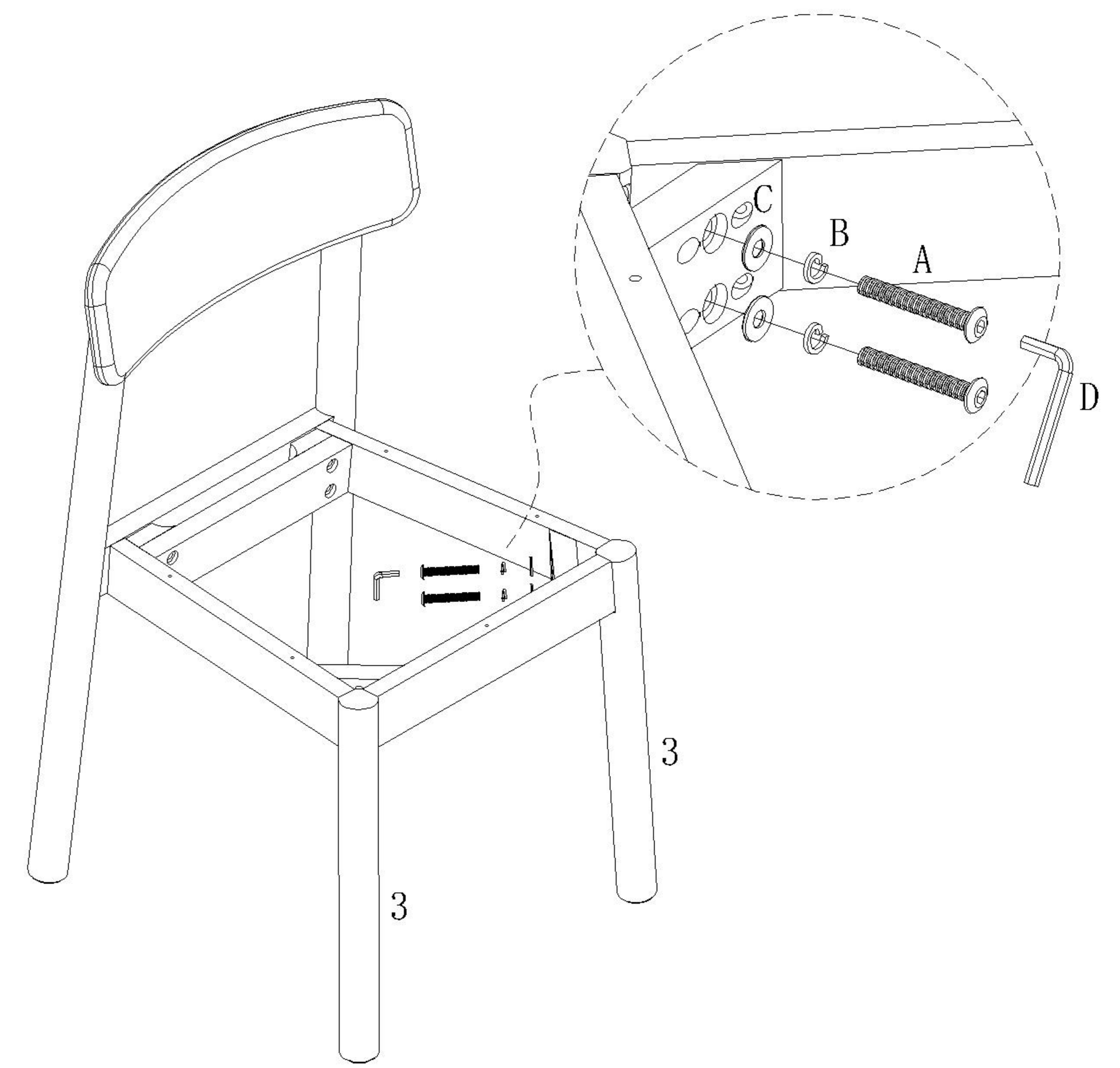

-  (A)\*1
-  (B)\*4
-  (C)\*4
-  (D)\*4

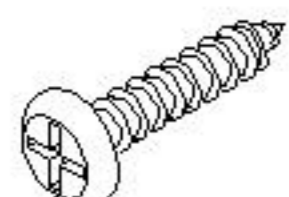

-  (E)\*5
-  (F)\*5

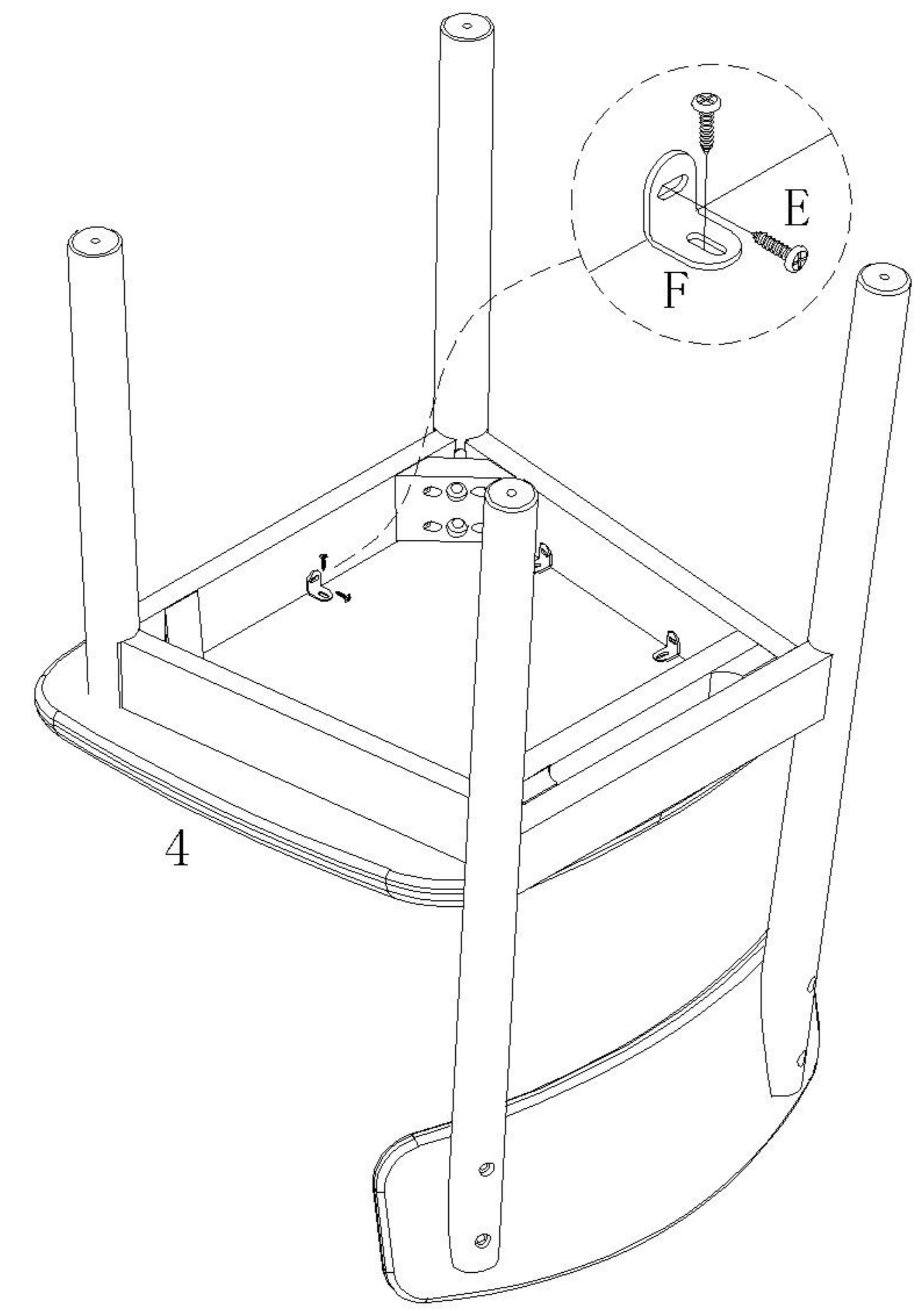

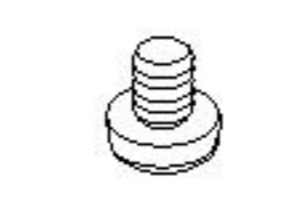
-  (G)\*4

