

LINSY 林氏家居

安装示意图

Installation diagram

产品名称
Product name
LS357R1-A

产品规格
Product specification
收拢/Collapse: 926*626*775mm
展开/Open: 1200*900*750mm

安装工具
Installation tools
安装人数
Number of Installers

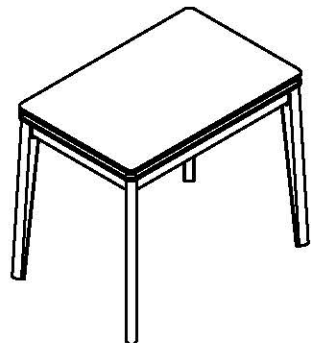
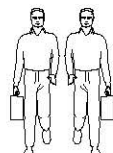

收拢/Collapse: 926*626*775mm

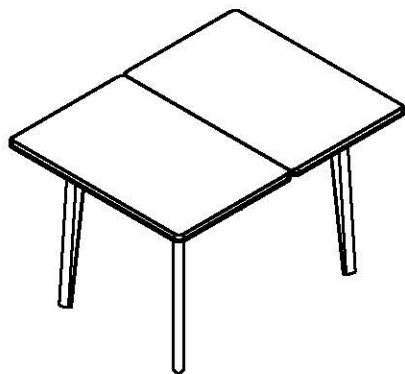

展开/Open: 1200*900*750mm

五金表/Hardware list

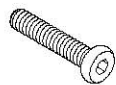

(A) *8
内六角螺钉 M8*80
Socket head cap screw



(B) *8
弹垫 Φ8
Spring washer



(C) *8
大垫圈 Φ8/Φ22
Large washer



(D) *1
内六角扳手 S5 (8mm)
Inner hexagon spanner



(E) *4
带牙胶脚钉
Adhesive foot nail with teeth

部件表/Parts list

编号 NO.	名称 Name	规格 Specifications	数量 QTY	材质 Material
①	脚柱 Foot column	718*68*40	4	橡胶木 Rubber wood
②	围框 Enclosure	840*540*70	1	三胺中纤板+橡胶木 Melamine MDF + Rubber wood
③	旋转面板 Rotate panel	900*596*25	1	三胺中纤板 Melamine MDF
④	翻板面板 Flap panel	900*596*24	1	三胺中纤板+岩板 Melamine MDF + Slate

LS357R1-A



(E) *4

安装方法

Installation method



带牙胶脚钉安装方法

Installation method of adhesive foot nail with teeth

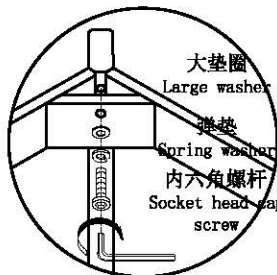

餐桌脚柱安装方法

Installation method of table foot column

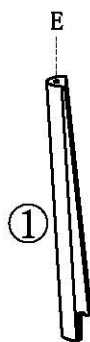

1

- (A) *8
- (B) *8
- (C) *8
- (D) *1

2

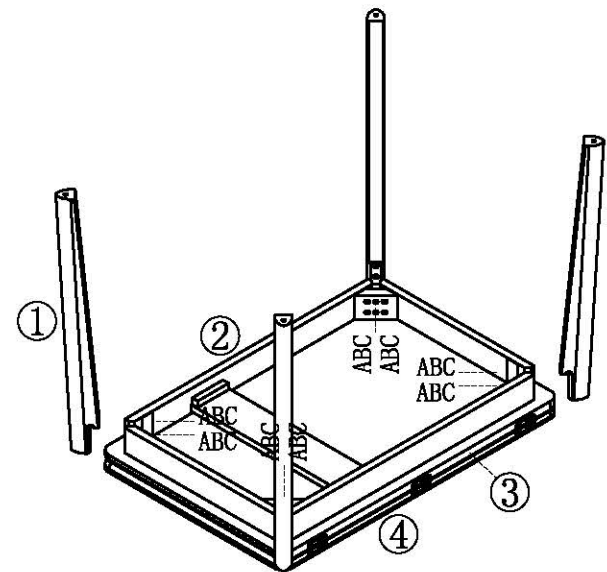

3

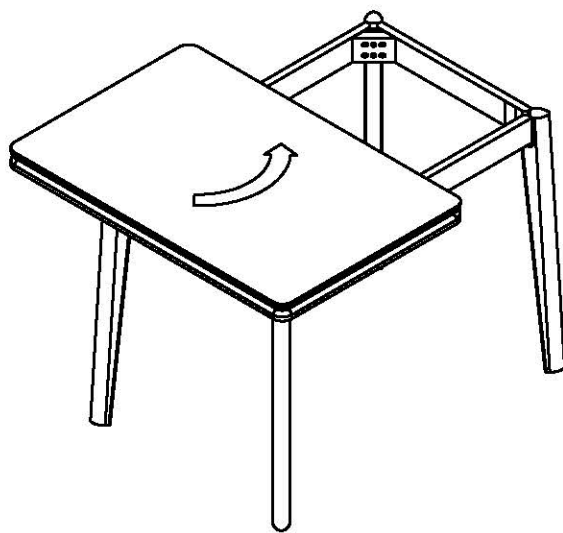

4

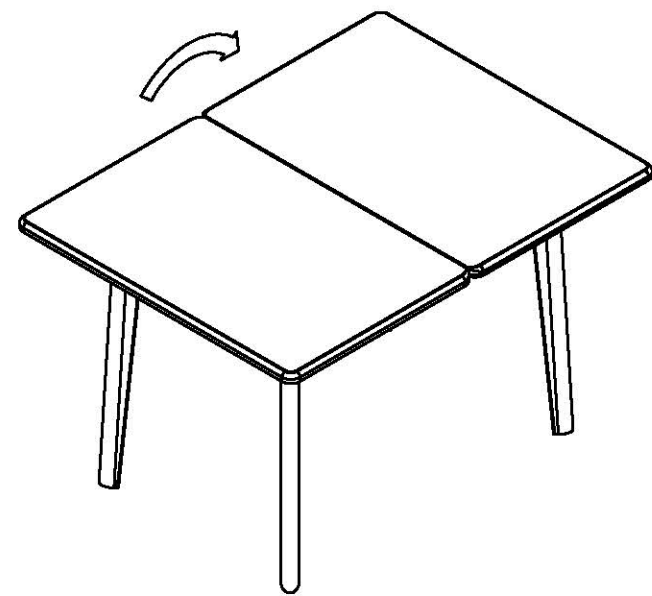

LINSY 林氏家居

五金表 Hardware list

部件表 Parts List

安装示意图 Installation diagram

产品名称 Product name: LH217S1-A1

产品规格 Product specifications: 445*480*815

安装工具 Tools required: 安装人数 No. of people required

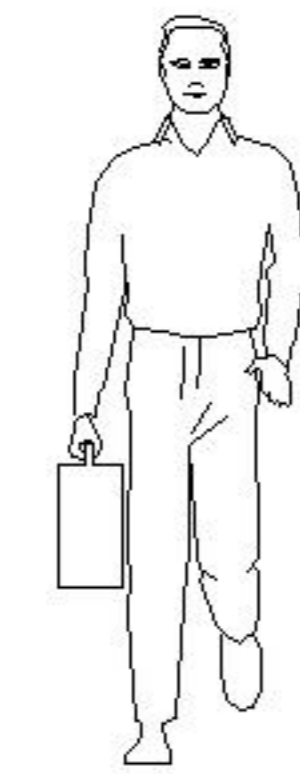
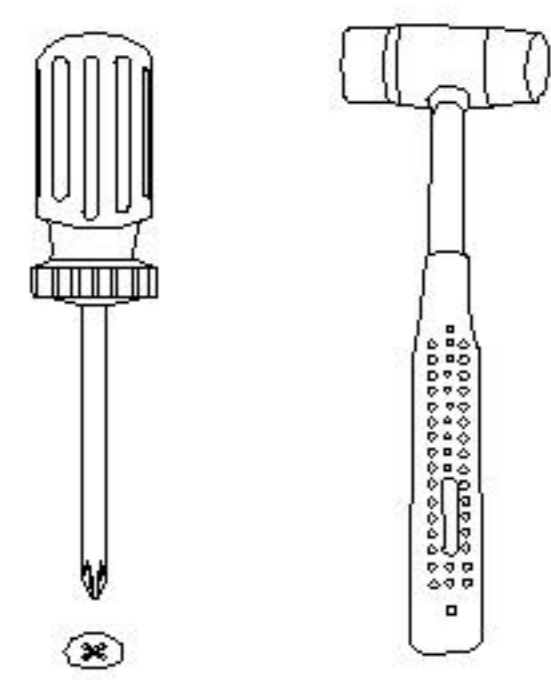

注:为保证设计效果,部分尺寸为定制尺寸,不影响使用。
 Note: To ensure design effectiveness, some sizes are customized and do not affect usage.

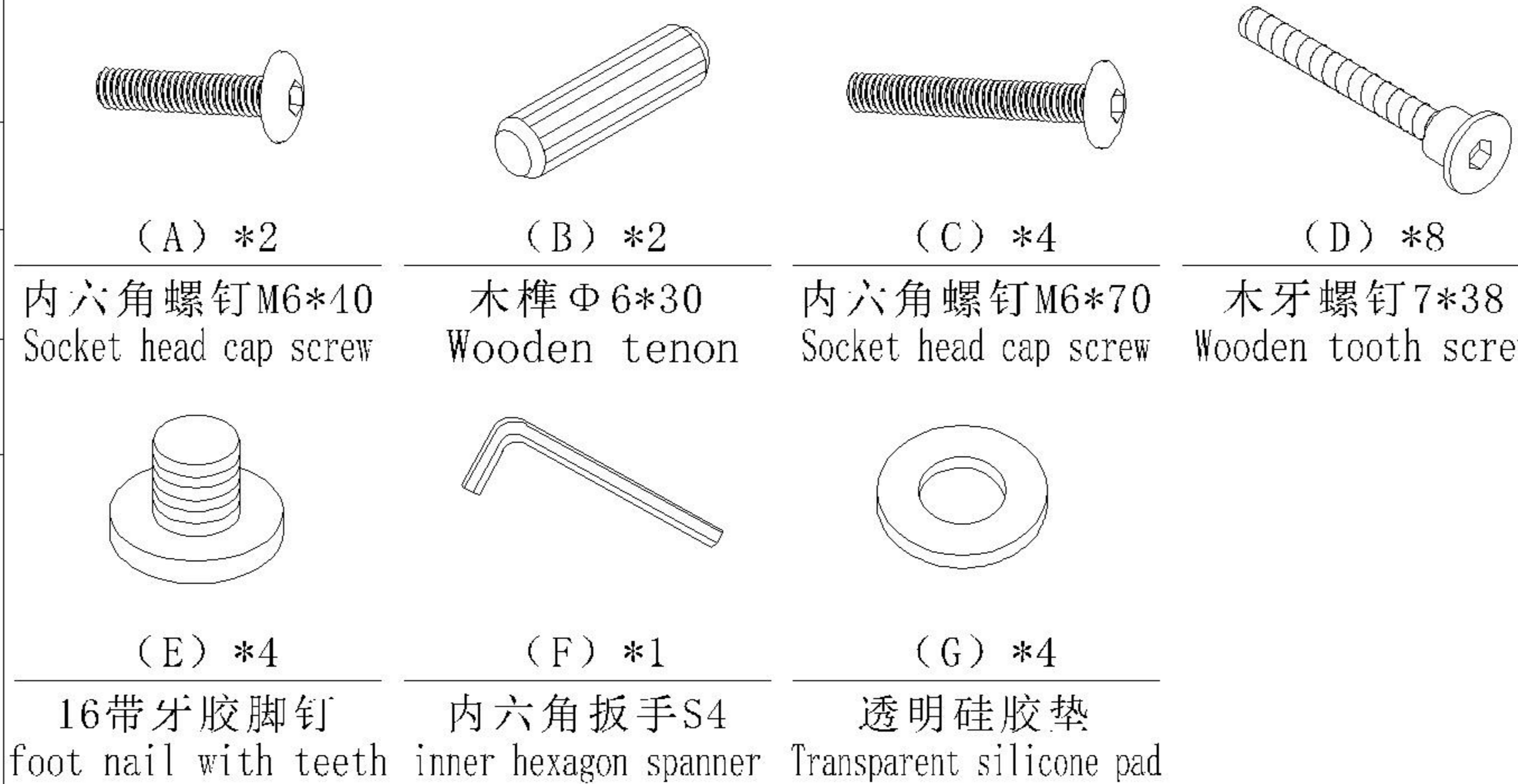
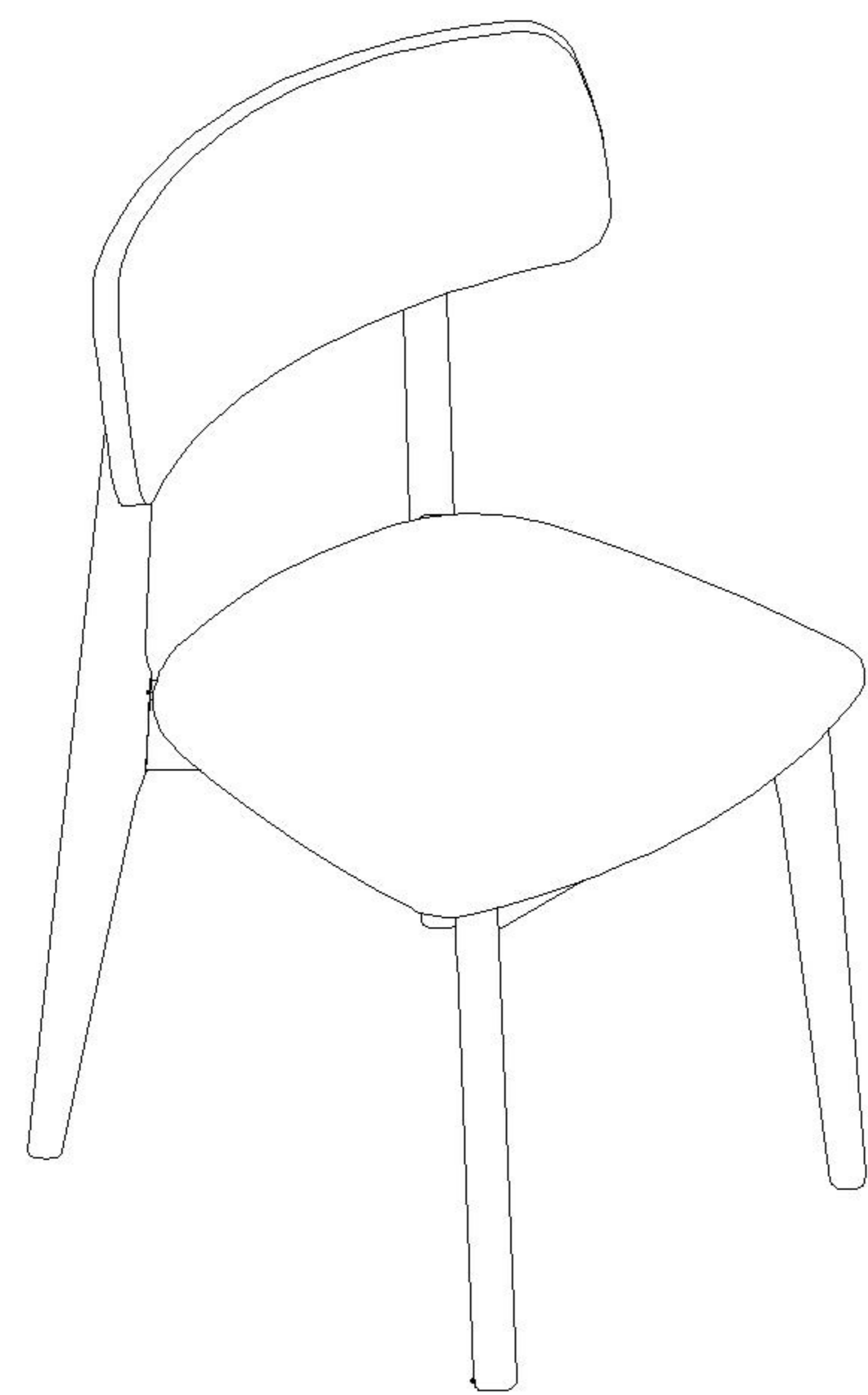

编号 NO.	名称 Name	规格 Specification	数量 QTY	材质 Material
①	下脚框 Understand	590*748*30	1	橡胶木 Rubber wood
②	上脚框 Upper tripod	590*748*30	1	橡胶木 Rubber wood
③	前角木 Front corner wood	275*58*22	1	橡胶木 Rubber wood
④	后角木 Rear corner wood	250*58*22	1	橡胶木 Rubber wood
⑤	软座板 Soft seat plate	445*440*12	1	中纤板+海棉+仿皮 MDF + sponge + fabric
⑥	背板 Backplane	435*197*18	1	中纤压弧板 Medium fiber curved pressure plate

LH217S1-A1

安装方法 Installation method

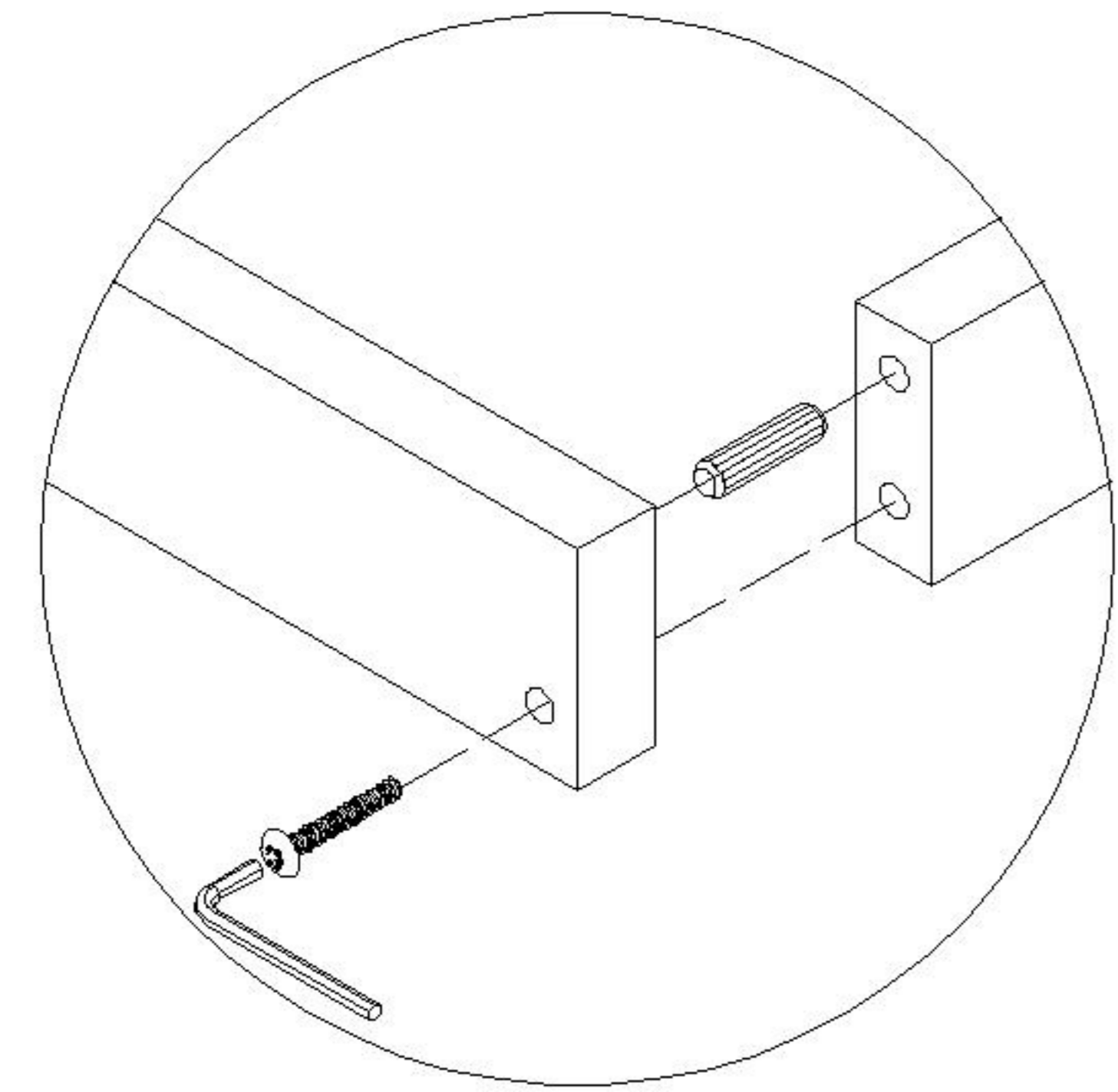

螺钉+木梢安装示意图
Installation diagram of
screw + wooden tenon

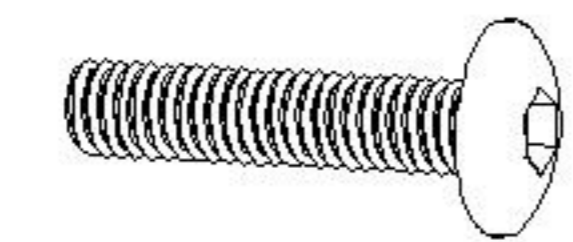

(A)*2

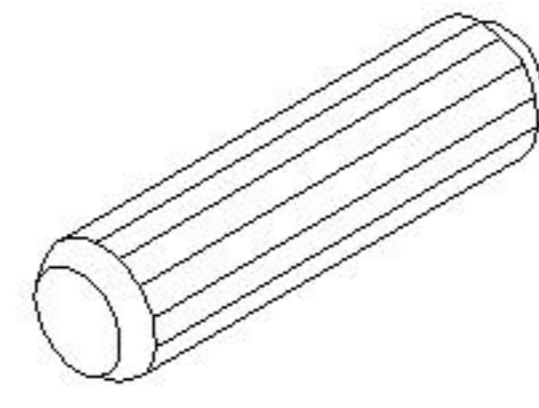

(B)*2

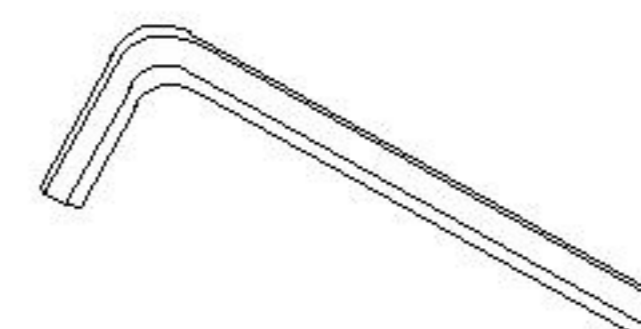

(F)*1

步骤1

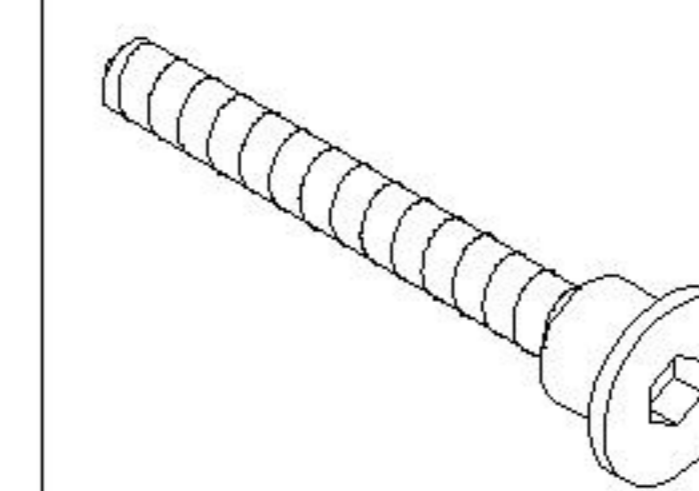
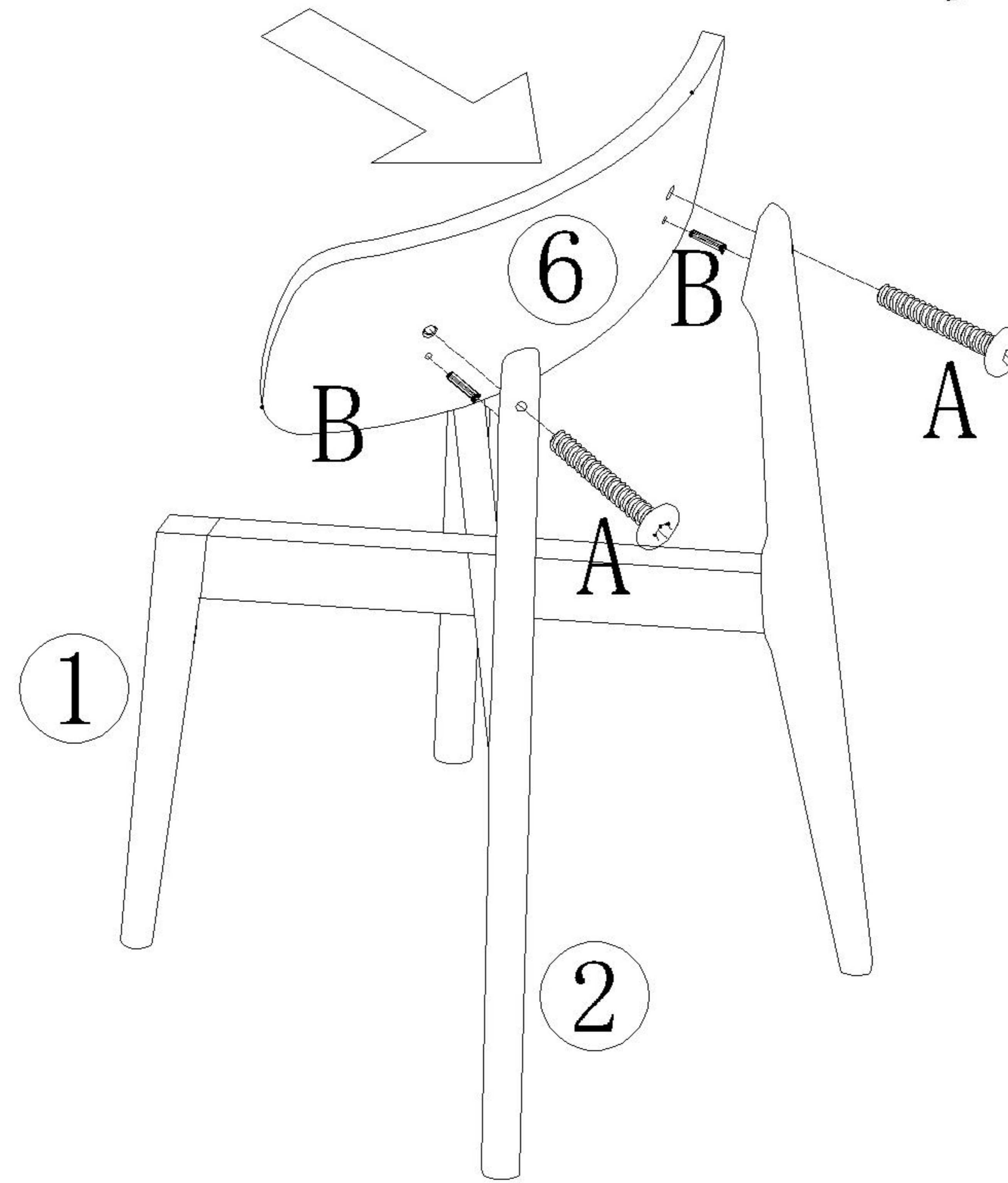

(D)*8

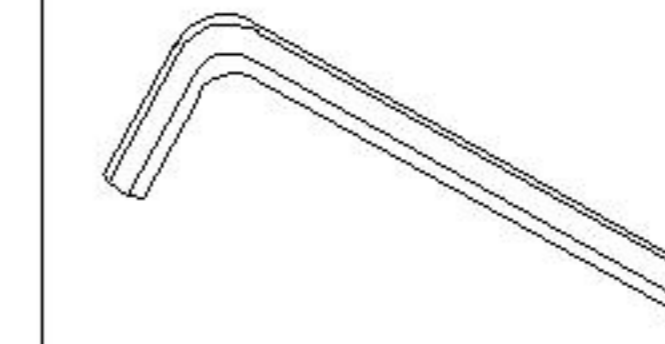

(F)*1

步骤2

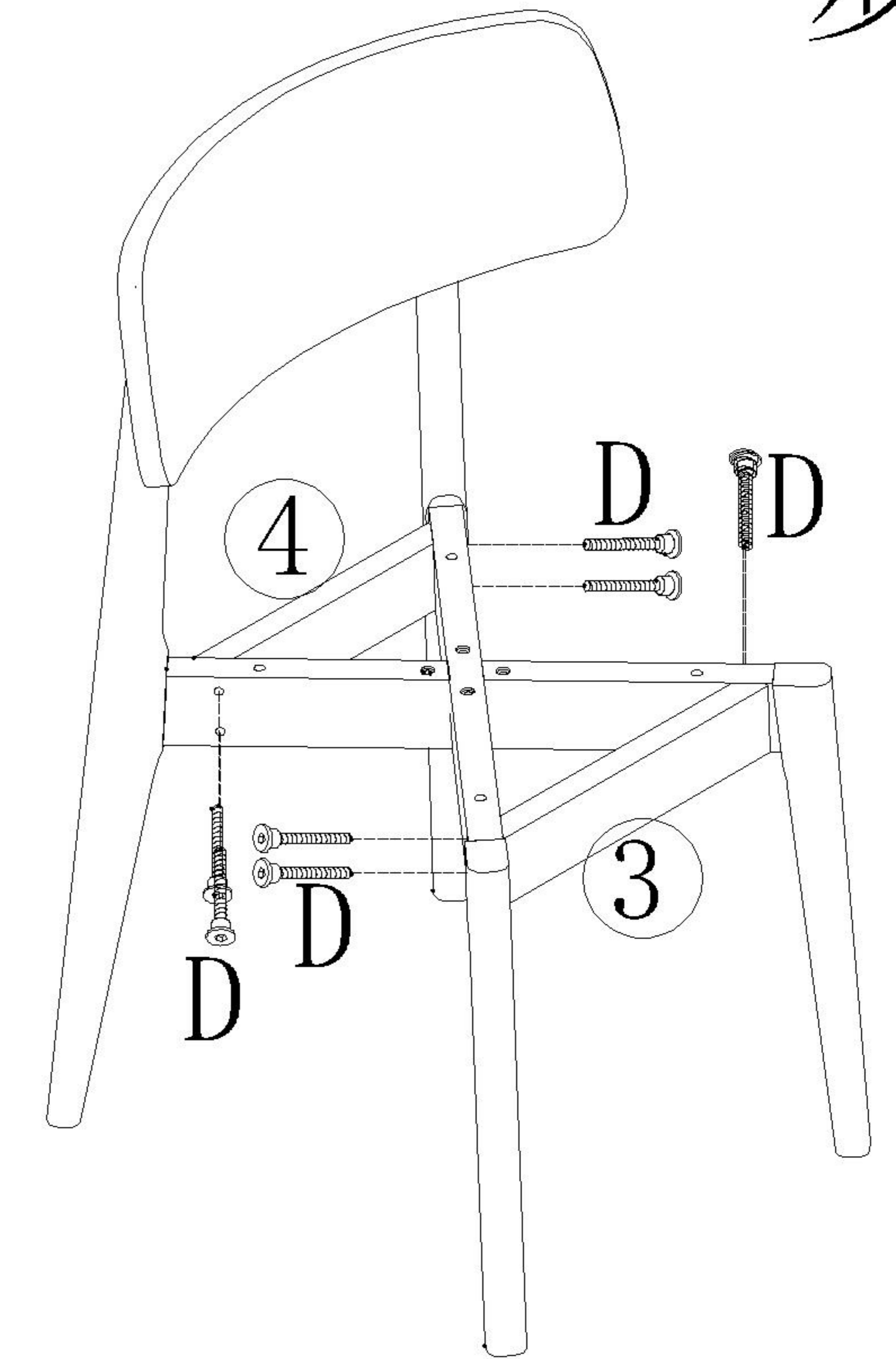

步骤3



(C)*4

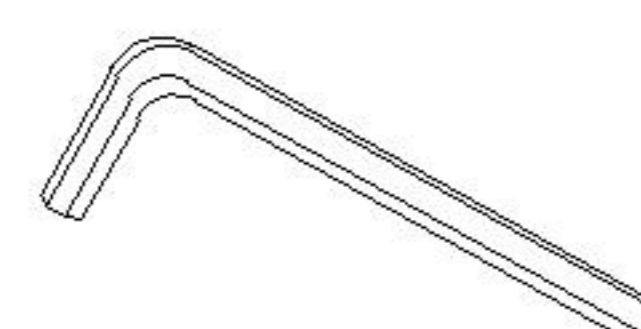

(F)*1

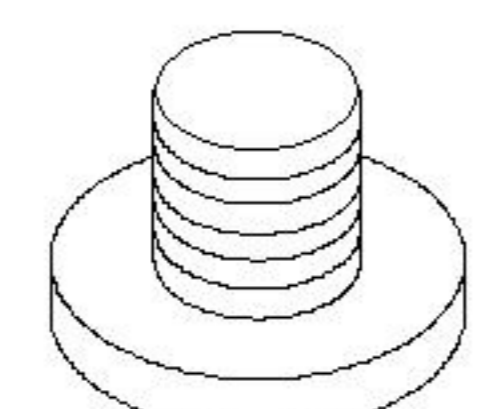

(E)*4

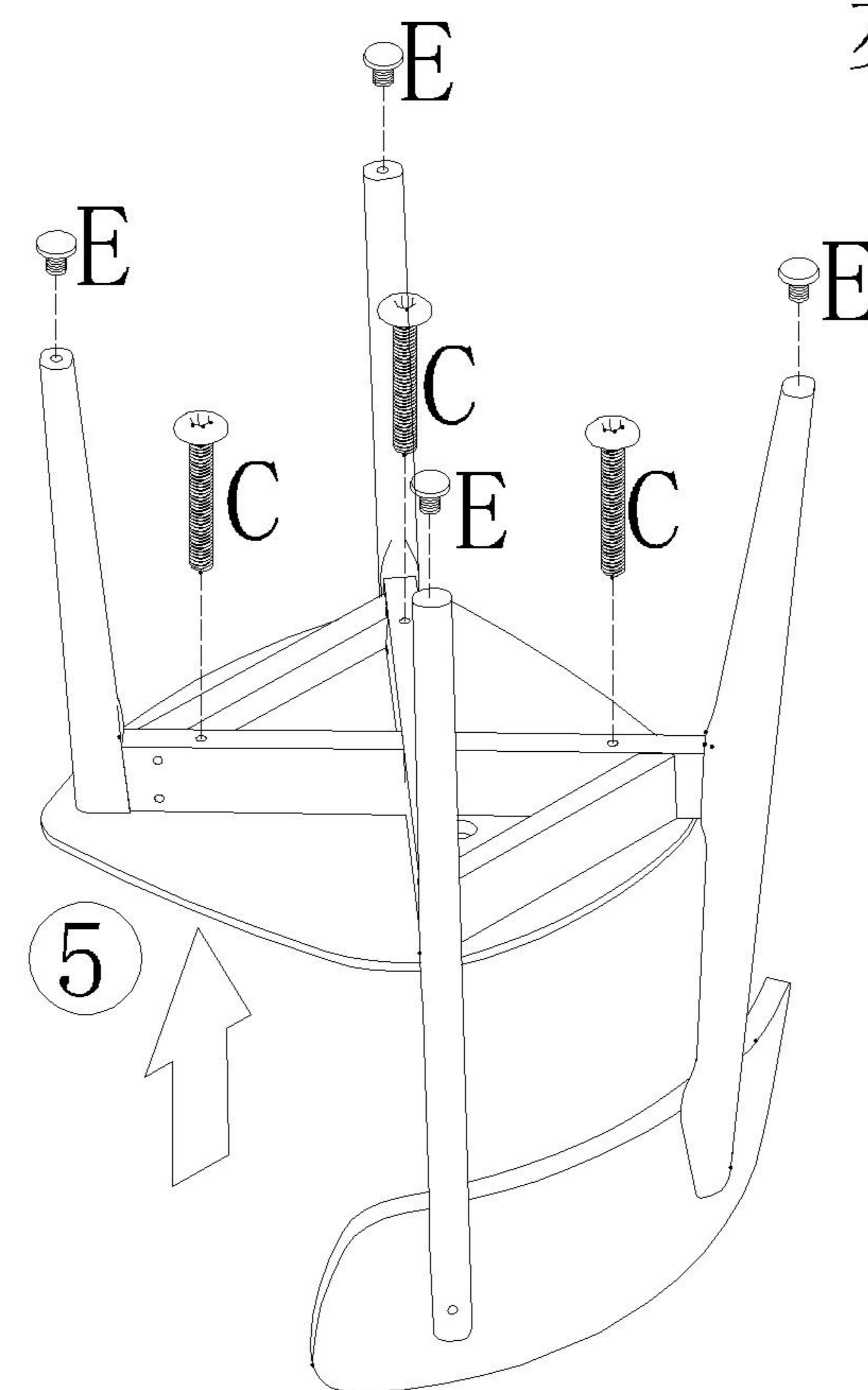

透明硅胶垫用于脚柱高低不平时，套于带胶脚钉上安装了矮的脚柱上
The transparent silicone pad is used for the uneven height of the foot post, which is covered on the foot nail with dental glue and installed on the low foot post

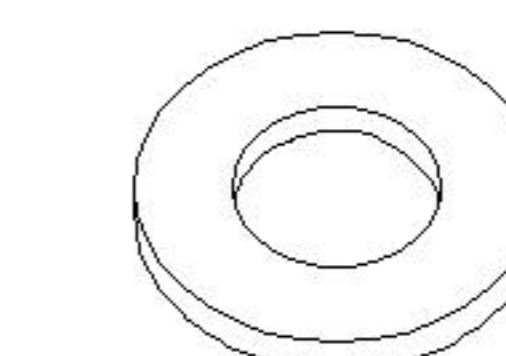
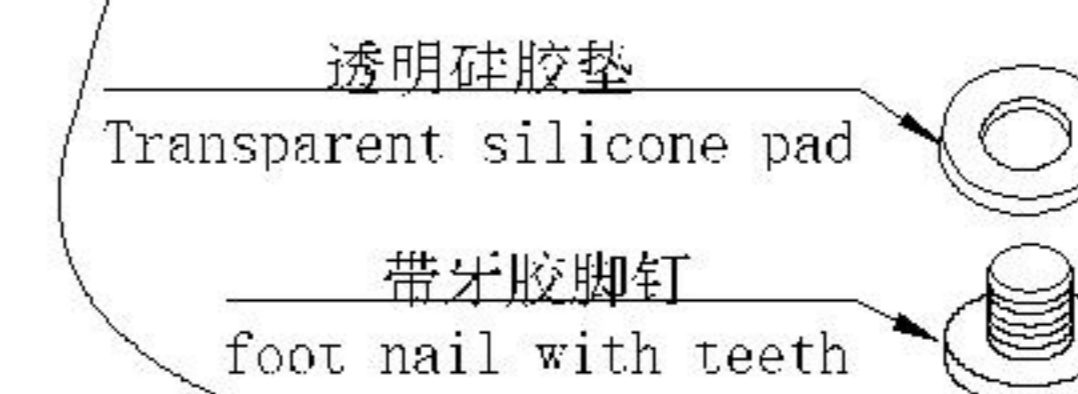

(G)*4

步骤4

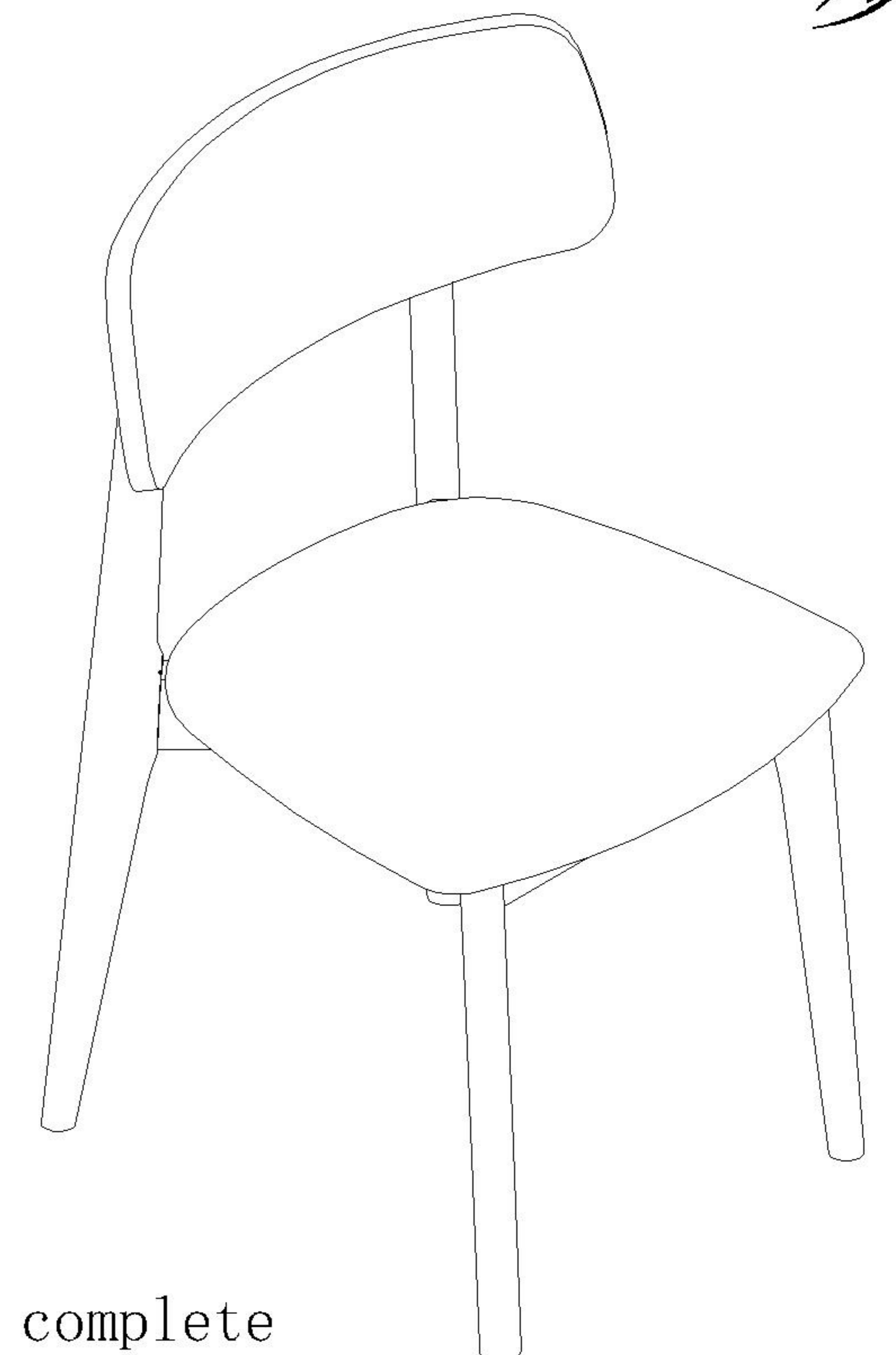

安装完成
installation is complete

脚钉安装示意图
Foot pin installation diagram

安装示意图/Assembly Instruction

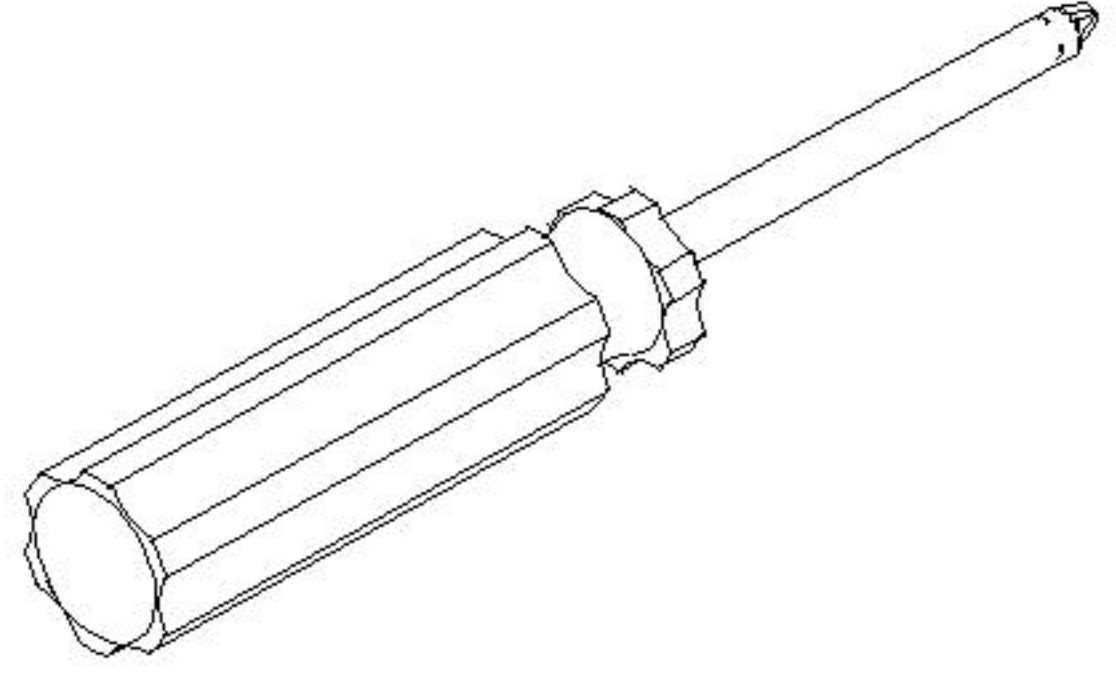
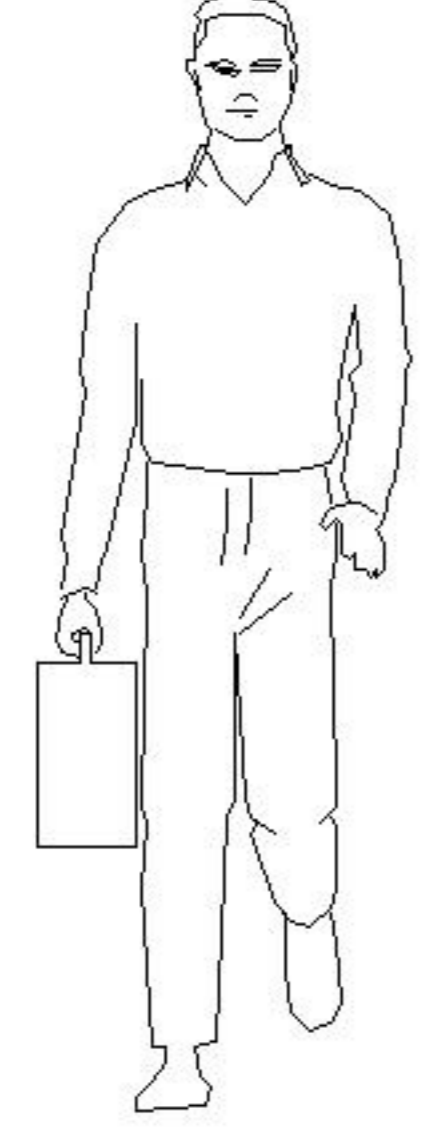
产品名称 Model NO.	圆餐凳 (2把装) 原木色
产品型号 Product Model	UB1S-A
产品规格 Specification	425*425*466
安装工具 Tool	安装人数 Installer
	

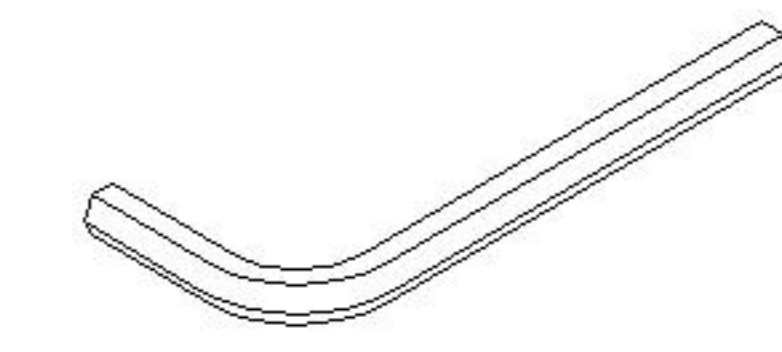
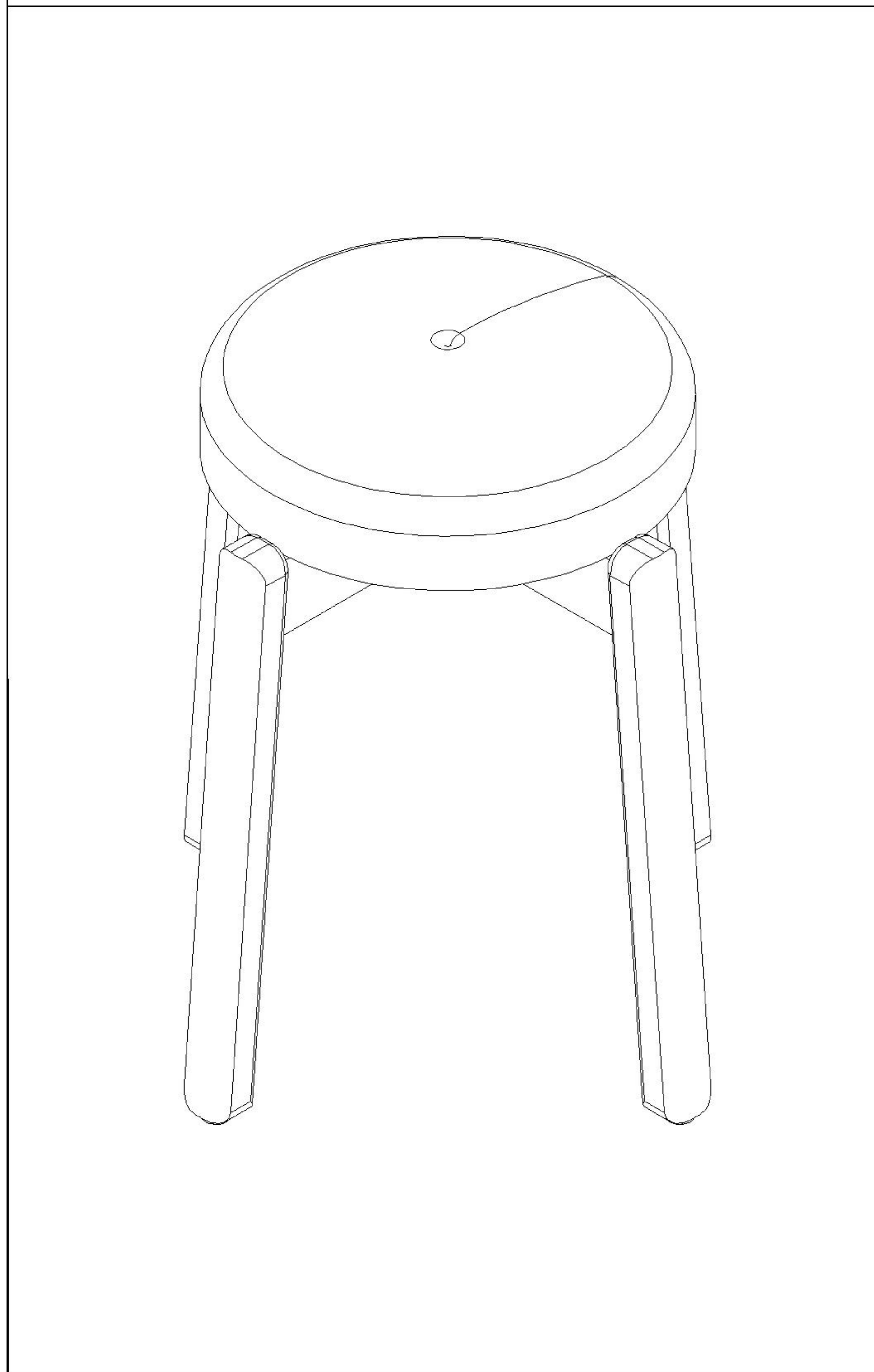

(A)*1
4mm内六角扳手
Wrench-(4mm)

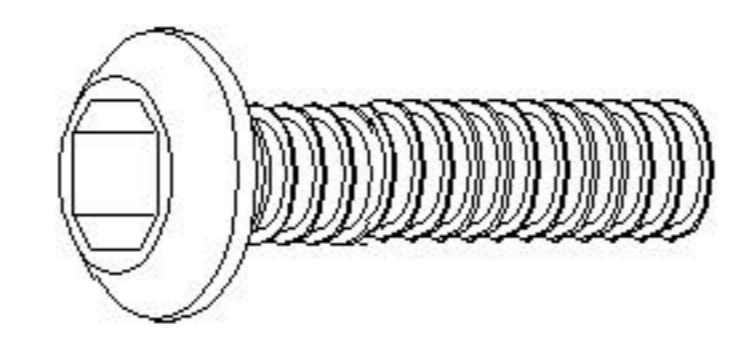

(B)*16
丝杆,斜边内六角
平头 M6*50
Lead screw, beveled
inner hexagon
Flat head M6*50

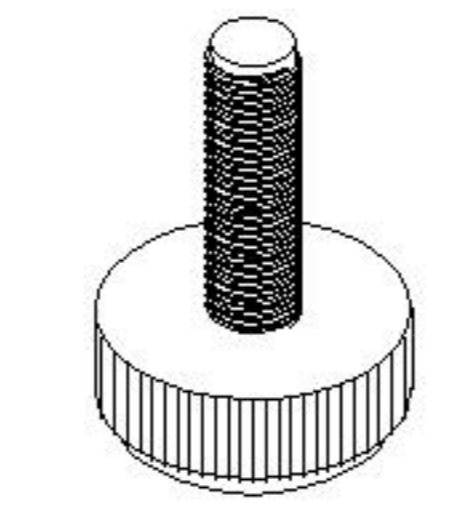

(C)*8
调节垫,黑色 Φ20*6
(丝杆M6*13)
Adjusting pad, black
Φ20*6 (lead screw
M6*13)

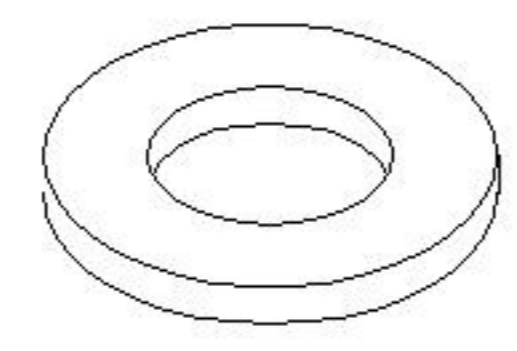

(D)*8
平垫,金属 Φ6*18*1.2
Flat washer,
metal Φ6*18*1.2

编号NO.	名称Name	规格Specification	数量QTY	材质Material
1	立脚1 Bottom frame	425*40*400	2	橡胶木 Rubber wood
2	立脚2 foot	425*40*400	2	橡胶木 Rubber wood
3	座板 Soft-padded seat board	Φ300*15	2	多层板+海绵皮料 Multi-layer board +leather material
4				

UB1S-A

安装方法/
Installation method



(A)*1

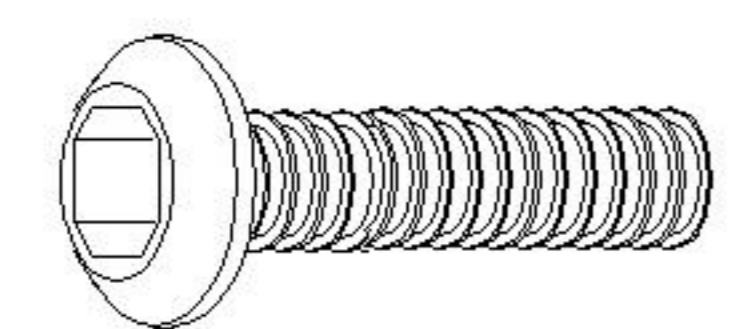

(B)*16

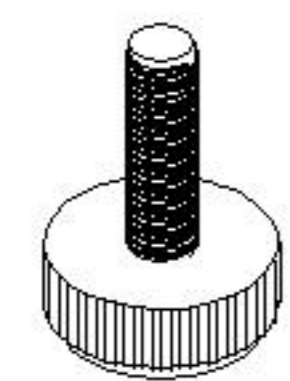

(C)*8

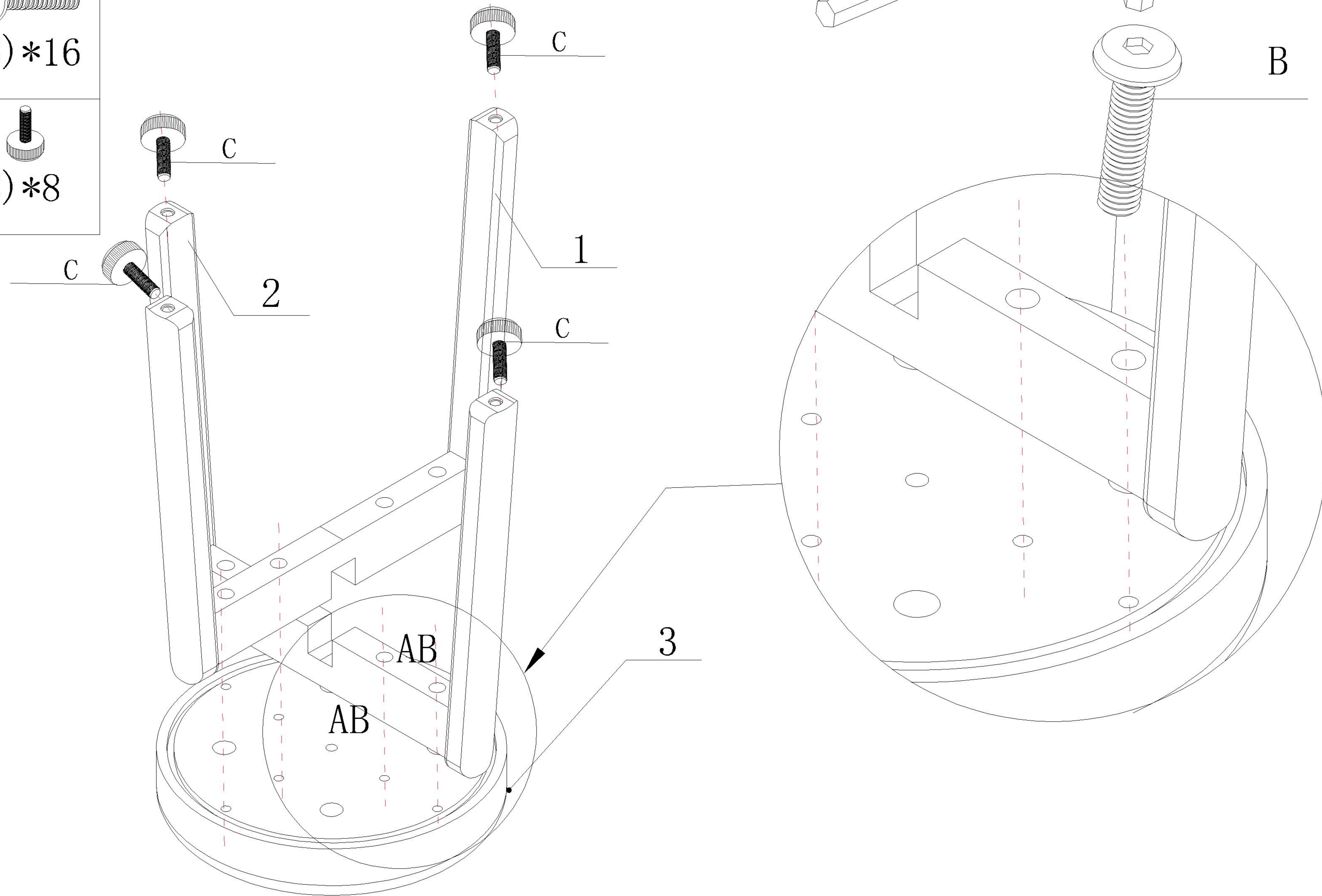

UB1S-A

安装方法/
Installation method

(D)*8

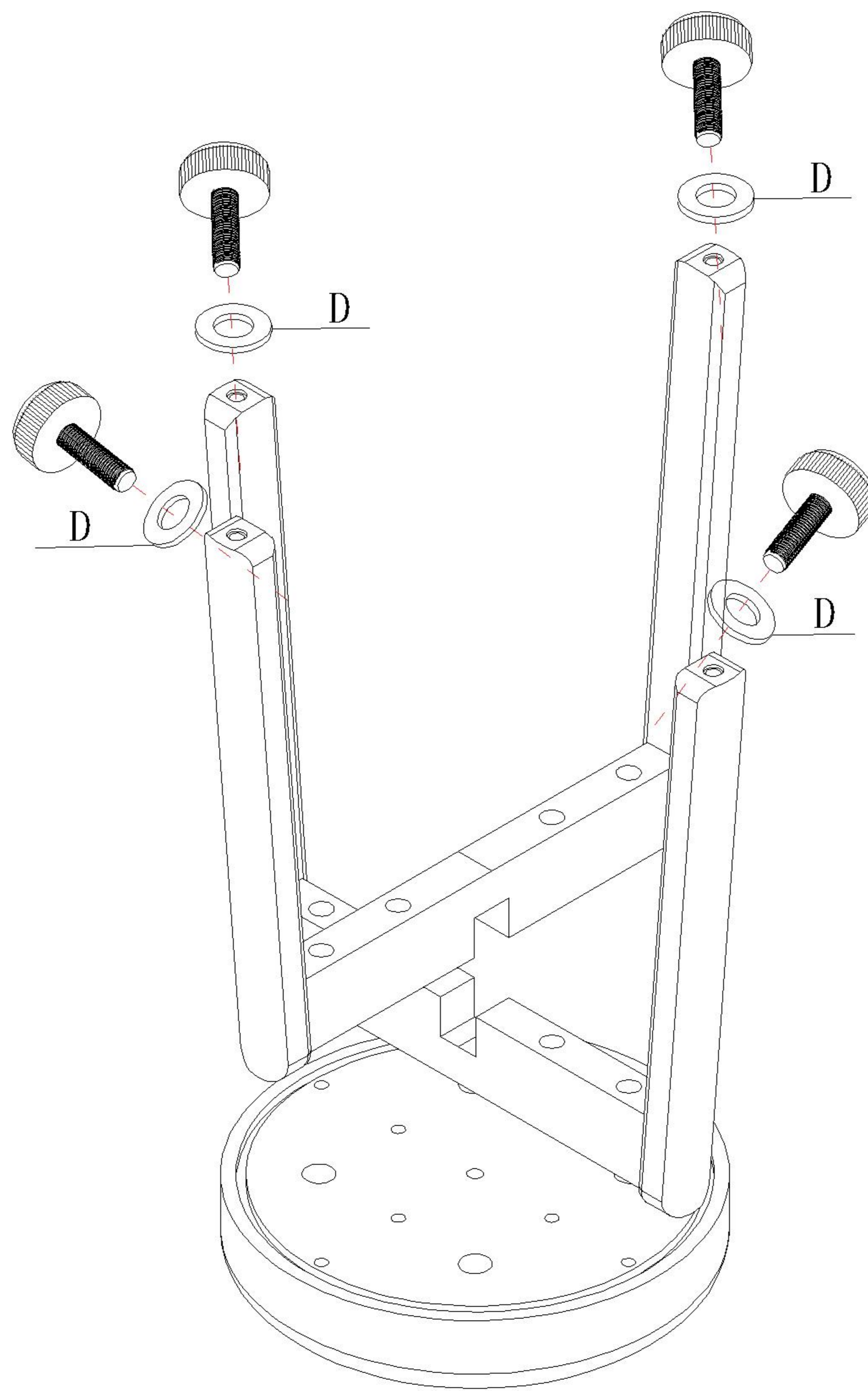
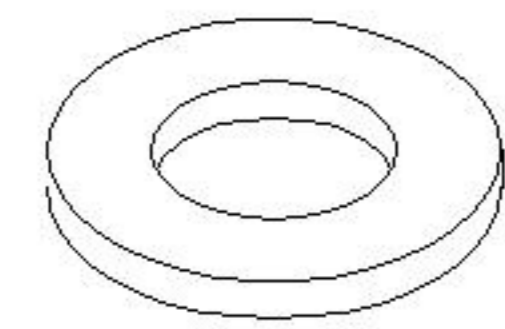

EN: The same board flipped 180°

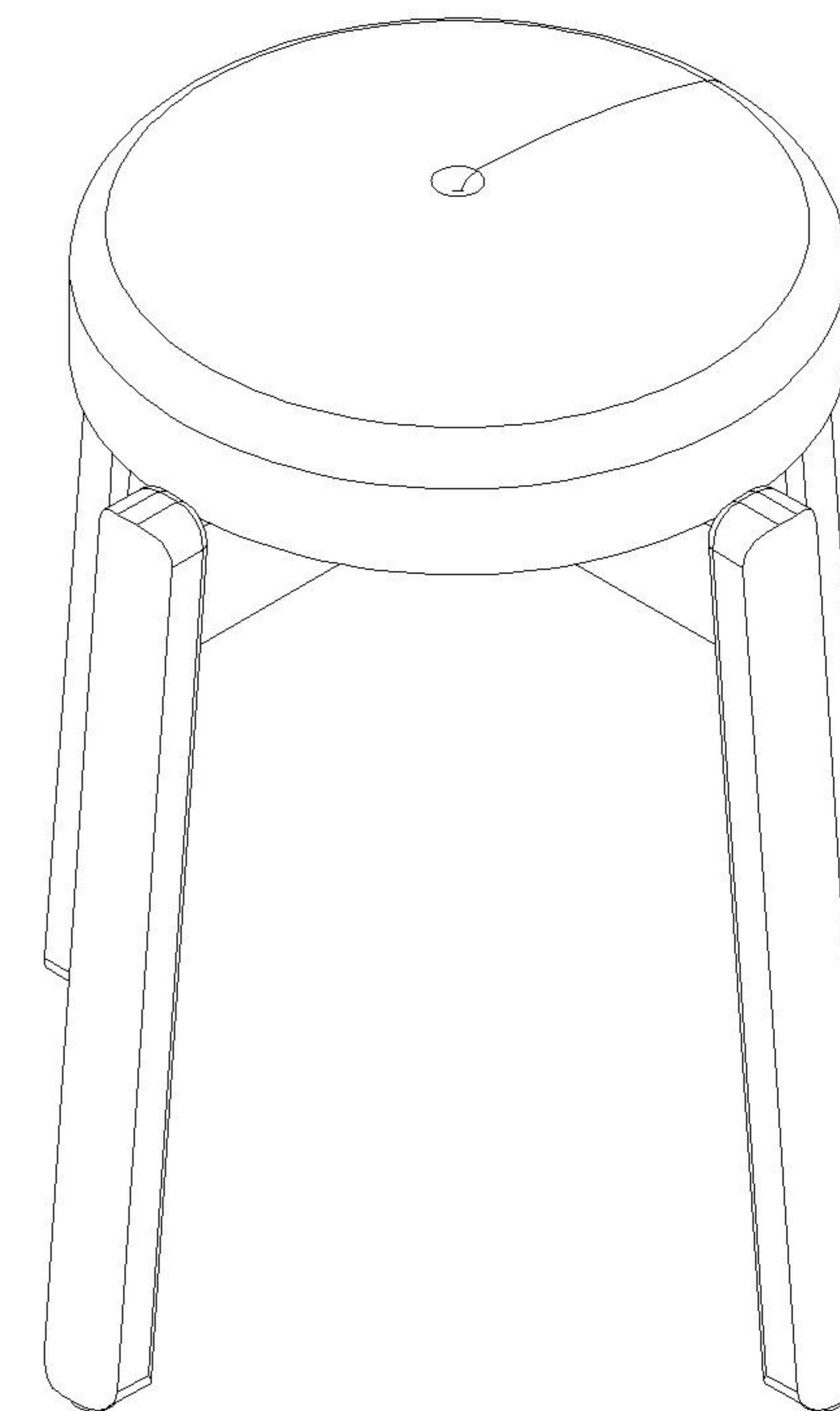

如遇不平,可按此图在相应脚端安装五金D调平底部(平放平整请忽略此步骤)

If there is an unevenness, you can install the hardware D to level the bottom according to this picture at the corresponding foot end (please ignore this step if it placed flat and even).