

# LINSY 林氏家居

## 安装示意图/Assembly Instruction

产品名称 Model NO BY137-A/C 产品规格 Specification 660mmW x 675mmD x 1070-1240mmH

安装工具 Tools required 安装人数 No. of people required

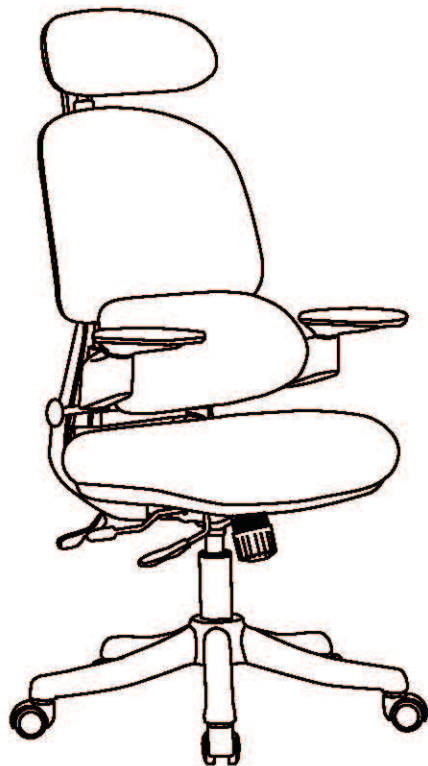
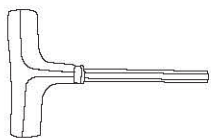

## 五金表 Hardware list

编号 NO	名称 Name	图示 Diagram	数量 QTY
Ⓐ	T字型扳手 T-shaped wrench		1
Ⓑ	大扁头内六角螺丝带弹簧 垫片与平垫片 Large flathead hexagonal screw with spring washer and flat washer	 M8X25mm	3
Ⓒ	大扁头内六角螺丝 Big flat head hexagonal	 M6X22mm	4

## 部件表 Parts List

编号 NO	名称 Name	规格 Specification	数量 QTY	材质 Material
①	背+扶手 back+armrest		1	塑料+布料 Plastic+Cloth
②	座垫 Cushion		1	布料+塑料+海绵 Cloth+Plastic+Sponge
③	脚 foot		1	塑料 Plastic
④	四级气杆 Class 4 gaslift		1	铁 Iron
⑤	PU 轮 PU wheel		5	铁+塑料 Iron+Plastic
⑥	托盘 Tray		1	铁 Iron
⑦	头枕 Headrest		1	塑料 Plastic

产品名称 Model NO BY137-A/C

## 安装示意图 Assembly Instruction

### STEP 1

将部件5 (PU轮) 插入部件3 (脚)

Insert part5 (PU wheel)  
into part3 ( foot)

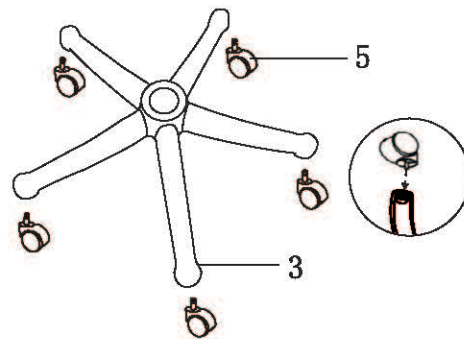

### STEP 2

将部件4 (四级气杆) 插入部件3 (脚)

Insert part4 (class 4 gaslift)  
into part3 ( foot)

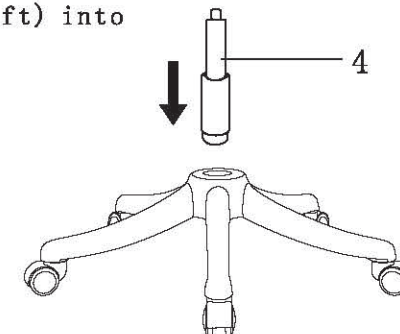

### STEP 3

将部件6 (托盘) 放置在部件2 (座垫)  
底部中心位, 使用五金C (M6\*22) 对  
准座垫的孔位锁紧固定。

Insert part 6 (tray) at the bottom center of  
part2 (seat cushion), and use hardware C  
(M6 \* 22) to align with the hole of the  
seat cushion and lock it in place.

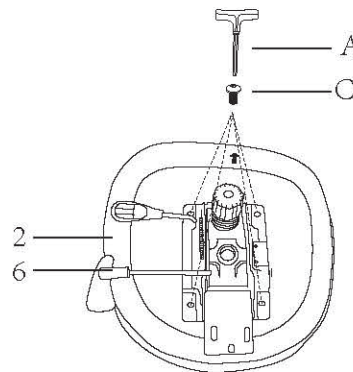

### STEP 4

将部件1 (背+扶手) 和部件6 (托  
盘) 孔位对齐, 使用五金B (M8\*25  
) 锁紧固定。

Align the holes of part 1 (backrest)  
and part 6 (tray), and secure them  
with hardware B (M8 \* 25)

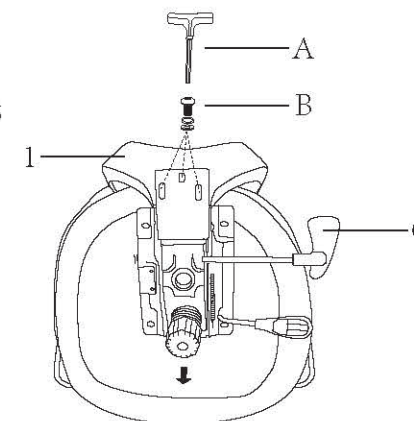

### STEP 5

将托盘孔对准气杆, 把组装好的靠背坐垫  
放到气杆上

Place the fully assembled back and seat  
cushion into the gaslift

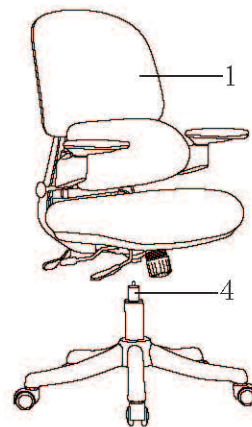

### STEP 6

将部件7 (头枕) 插入  
到部件1 (背+扶手)

Insert part7 (headrest) into  
part 1 (backrest).

