

# LINSY 林氏家居

## 安装示意图/Assembly Instruction

产品名称 Model NO | BY122-A/B/C | 产品规格 Specification | 650\*650\*1230-1290mm

安装工具 Tools required | 安装人数 No. of people required

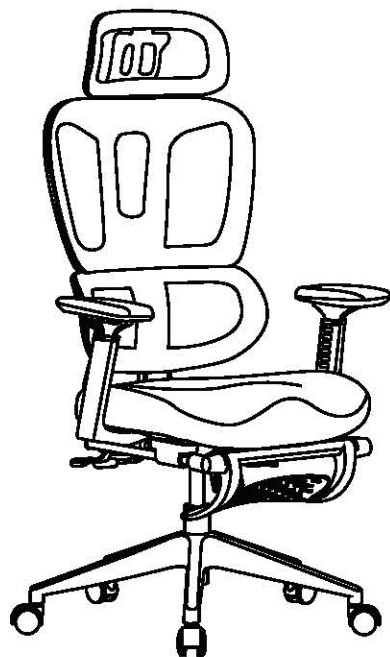
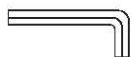

## 五金表 Hardware list

编号 NO	名称 Name	图示 Diagram	数量 QTY
Ⓐ	内六角扳手 Wrench-(7mm)		1
Ⓑ	大扁头内六角 M6*25 Hexagon Socket Flat Head Screw, M6*25		3
Ⓒ	大扁头内六角带垫 M6*20 Hexagon Socket Flat Head Screw, M6*20		6
Ⓓ	大扁头内六角带垫 M8*25 Hexagon Socket Flat Head Screw, M8*25		3
Ⓔ	大扁头内六角 M6*35 Hexagon Socket Flat Head Screw, M6*35		2
Ⓕ	大扁头内六角 M6*40 Hexagon Socket Flat Head Screw, M6*40		4

## 部件表 Parts List

编号 NO	名称 Name	规格 Specification	数量 QTY	材质 Material
①	背 Back		1	塑料+布料 Plastic+Cloth
②	座垫 Cushion		1	布料+海绵+胶合板 Cloth+Sponge+ Plywood
③	左扶手 Right armrest		1	塑料 Plastic
④	右扶手 Left armrest		1	塑料 Plastic
⑤	脚 Foot		1	塑料 Plastic
⑥	托盘 Tray		1	铁 Iron
⑦	三级气杆 Class 3 gaslift		1	铁 Iron
⑧	PU轮 PU wheel		5	铁+塑料 Iron+Plastic
⑨	头枕 Headrest		1	塑料+布料 Plastic+Cloth
⑩	背支架 Back support		1	塑料 Plastic
⑪	靠背装饰盖 Back Cover		1	塑料 Plastic
⑫	头枕装饰盖 Headrest Cover		1	塑料 Plastic

## STEP 1

将部件8(PU轮)插入部件5(脚)组装好的上部分通过部件7(气杆)插入部件5(脚)

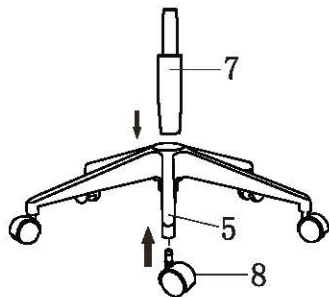

Insert part 8 (PU wheel) into the assembled upper part of part 5 (foot) through part 7 (gas lift) into part 5 (foot)

## STEP 2

用五金E (M6\*35)和五金F (M6\*40) 将部件3(左扶手)和部件4(右扶手)和部件2(座垫)紧锁固定Secure part 3 (left armrest), part 4 (right armrest) and part 2 (cushion) tightly with hardware E (M6\*35) and hardware F (M6\*40)

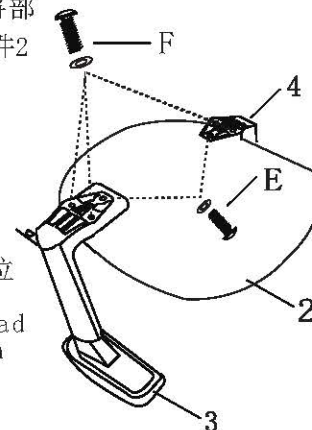

备注：请把每个扶手3颗螺丝对准孔位拧到螺纹，再100%拧紧  
Note: Align and partially thread the 3 screws per handrail, then fully tighten all to 100%.

## STEP 3

将部件6(托盘)放置在部件2(座垫)底部的中心位，使用五金C (M6\*20)对准座垫的孔位锁紧固定

Place part 6 (tray) in the center position at the bottom of part 2 (Cushion), and use hardware C (M6 \* 20) to align with the hole position of the seat cushion and lock it tightly

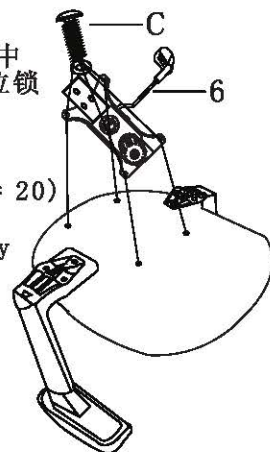

## STEP 4

用五金D (M8\*25)将部件10(背支架)和部件6(托盘)紧锁固定

Secure part 10 (back support) and part 6 (tray) tightly with hardware D (M8\*25)

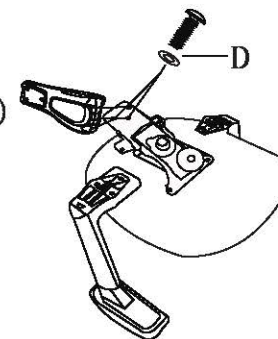

## STEP 5

将部件10(背支架)与部件1(背)用五金B (M6\*25)连接，再用部件11(靠背装饰盖)盖住装螺丝部位

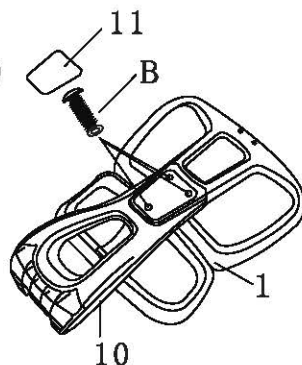

Connect part 10 (back bracket) to part 1 (back frame) using hardware B (M6\*25), then cover the screw installation area with part 11 (back cover).

## STEP 6

用五金C (M6\*20) 将部件9(头枕)与部件1(背)紧锁固定，再用部件12(头枕装饰盖)盖住装螺丝的部位。至此，安装完毕

Secure part 9 (headrest) and part 1 (back) tightly with hardware C (M6\*20), , then cover the screw installation area with part 12 (headrest cover).

The installation is completed

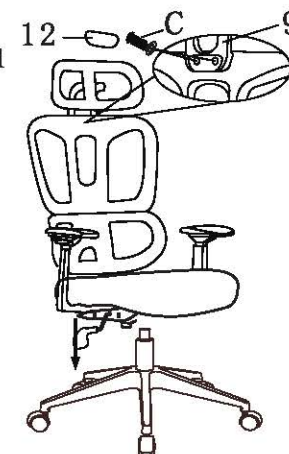

产品名称  
Model NO

BY122-A/B/C

安装示意图  
Assembly Instruction