

LINSY 林氏家居

五金表/Hardware list

部件表/Parts List

安装示意图/Assembly Instruction

产品名称 Model NO.	BY051-A/B Computer Chair
产品规格 Specification	710*705*1180~1255
安装工具 Tool	安装人数 Installer



(A)*1 6mm内六角扳手 Wrench-(6mm) Hexagon bar wrench	(B)*4 圆头内六角螺丝6*20 Round head hexagon screw-(6*20) black	(C)*3 平头内六角螺丝8*20 Round head hexagon screw-(8*20) black	(D)*6 圆头内六角螺丝6*40 Round head hexagon screw-(6*40) black
(E)*2 平头内六角螺丝8*15 Flat Head Hexagon screw-(8*15) black	(F)*3 圆头内六角螺丝6*30 Round head hexagon screw-(6*30) black	(G)*2 靠背软扣盖 plastic cover	(H)*5 PU万向轮 Pu Wheel
(I)*1 防尘套 dustproof cover	(J)*1 三级气压棒 3 class gas lift		

编号NO.	名称Name	规格 Specification	数量QTY	材质Material
①	靠背-左 Backrest	430*220*110	1	PP+ Foam+Mesh PP+海绵+网布
②	靠背-右 Backrest	430*220*110	1	PP+ Foam+Mesh PP+海绵+网布
③	座垫 Seat	540*485*90	1	PP+ Foam+Mesh PP+海绵+网布
④	椅脚330# Chair Base-330mm	330mm	1	PP+FG/PP+玻璃纤维
⑤	双手柄可躺托 Recliner Mechanism		1	Steel/铁
⑥	扶手-左 Armrest -Left		1	PP+FG/PP+玻璃纤维
⑦	扶手-右 Armrest -Right		1	PP+FG/PP+玻璃纤维
⑧	头靠手轮 Head on the handwheel		1	PP+FG/PP+玻璃纤维
⑨	头靠钢管 Head on the pipe		1	Steel/铁
⑩	靠背塑料板 Backrest plastic sheet		1	PP+FG/PP+玻璃纤维
⑪	头靠 Headrest		1	Steel+PP/铁+PP

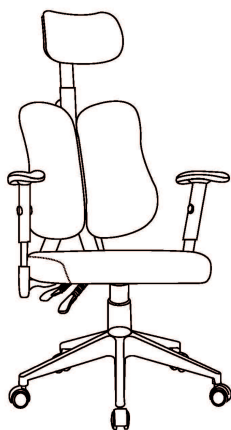

BY051-A无脚托

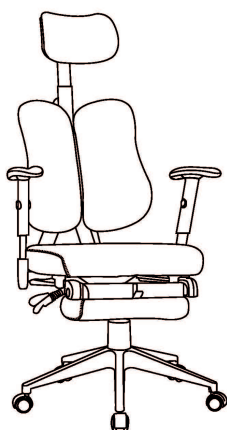

BY051-B有脚托

备注：2款产品说明书通用

扫一扫获取安装视频教程
Scan for installation video



第一步:扫码自动跳转林氏公众号页面
Step 1: Scan the code to automatically jump to the page of Linsy Official Accounts.

第二步:下拉页面至安装视频位置
Step 2: Pull down the page to the installation video location.

BY051-A/B Computer Chair

安装方法/Installation method

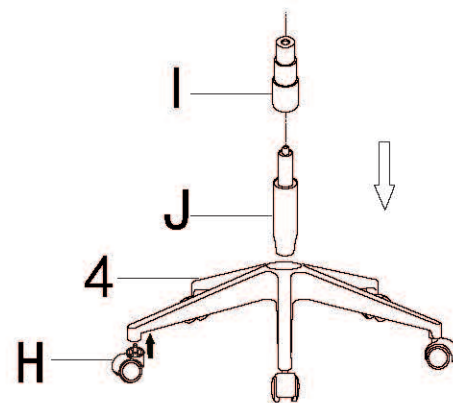

把椅轮H分别装入椅脚4的五个脚孔，再将气压棒J装入椅脚4的中心孔，最后套上防尘套I
 Install the gaming wheels H into the five holes of the chair base 4, then install the gas lift J into the center hole of the chair base 4, and finally put on the dustproof cover I

1

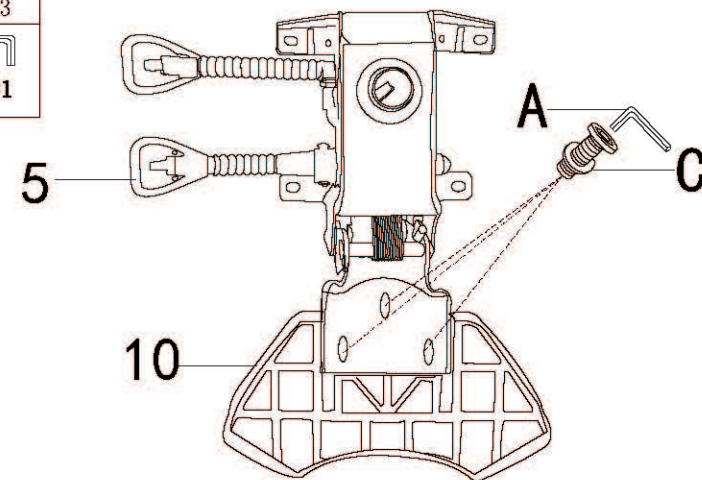
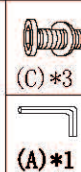

将靠背塑板10与双手柄可躺托5孔位对准，使用五金C对准孔位锁紧固定
 Align the backrest plastic plate 10 with the chassis 5 hole position, and lock and fix it with the hardware C alignment hole position

2

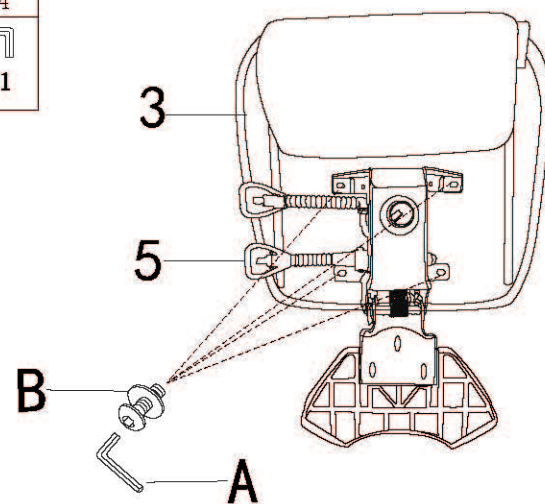
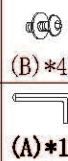

将双手柄可躺托5放置在坐垫3的中心位，使用五金B对准坐垫3的孔位
 The chassis 5 is placed in the center of the Cushion 3, and the hole of the cushion 3 is locked and fixed with hardware B

3

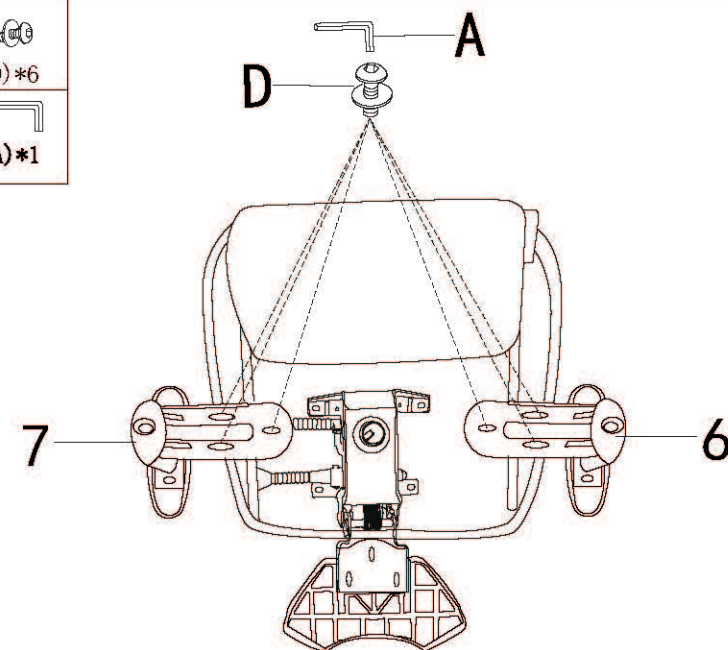
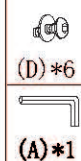

将座垫3用扶手5、6进行连接，使用五金D对准座垫3的孔位锁紧固定
 The seat Cushion 3 is connected with armrests 6 and 7 and the hole of the seat cushion 3 is locked and fixed with hardware D

4

BY051-A/B Computer Chair

安装方法/Installation method

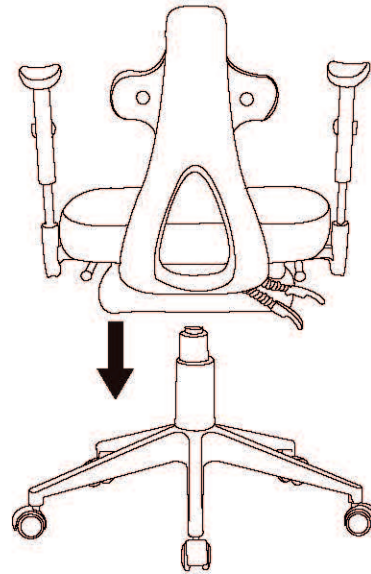

将气杆的顶端对准底盘的孔位对接，椅子下半部分按照完成
Align the top of the air rod to the hole of the chassis,
and the bottom half of the chair is finished

5

(F)*3

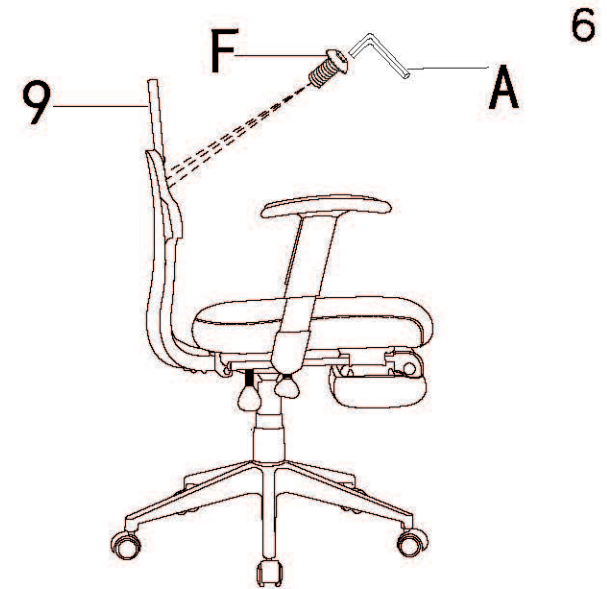

(A)*1



将头靠钢管板9与靠背塑料板进行连接，使用五金F对准靠背塑料板与头靠钢管孔位紧
The head against steel tube plate 9 is connected with the backrest plastic plate,
and the head against steel tube hole is tightly aligned with the backrest plastic
plate by using hardware F

(E)*2

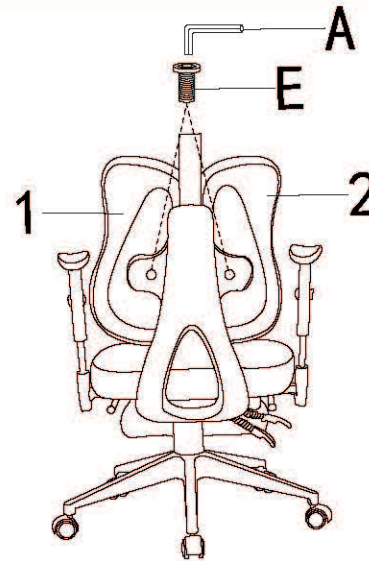

(A)*1



将靠背塑料板10与靠背1、2进行连接，使用五金E对准靠背塑料板和靠背孔位锁紧
The backrest plastic plate 10 is connected with the backrest 1 and 2,
and the backrest plastic plate and the backrest hole are locked using
the hardware E

7

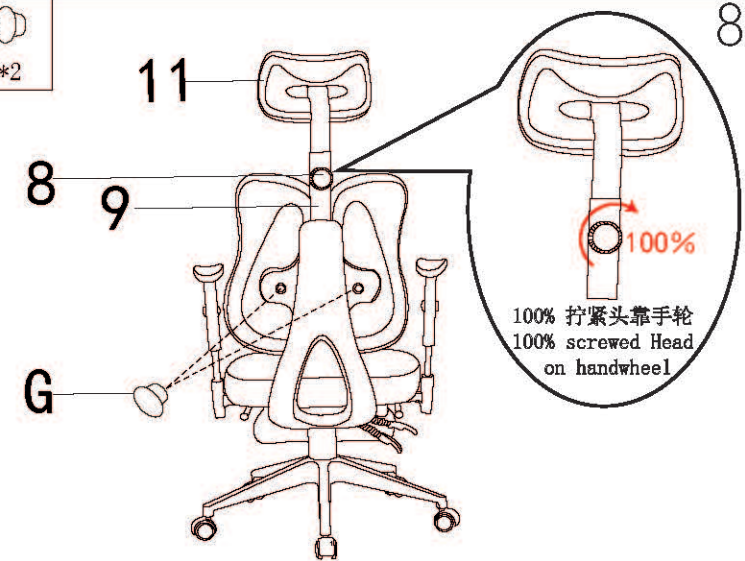
(G)*2



将头靠11插进头靠钢管9，用头靠手轮8顺时针旋紧，再使用打盖G打住靠背孔位。
安装完成

Insert the head against 11 into the head against the steel tube 9, turn the head
against the handwheel 8 clockwise tight, and then use the touch cover g to
touch the backrest hole. Installation complete

8

LINSY 林氏家居

五金表/Hardware list

部件表/Parts List

安装示意图/Assembly Instruction

产品名称 Model NO.	BY051-A/B Computer Chair
产品规格 Specification	710*705*1180~1255
安装工具 Tool	安装人数 Installer



(A)*1 6mm内六角扳手 Wrench-(6mm) Hexagon bar wrench	(B)*4 圆头内六角螺丝6*20 Round head hexagon screw-(6*20) black	(C)*3 平头内六角螺丝8*20 Round head hexagon screw-(8*20) black	(D)*6 圆头内六角螺丝6*40 Round head hexagon screw-(6*40) black
---	--	--	--

(I)*1 防尘套 dustproof cover	(J)*1 三级气压棒 3 class gas lift	(G)*2 靠背软扣盖 plastic cover	(H)*5 PU万向轮 Pu Wheel
---------------------------------	------------------------------------	---------------------------------	----------------------------

编号NO.	名称Name	规格 Specification	数量QTY	材质Material
①	靠背一套 Backrest		1	PP+Foam+Mesh PP+海绵+网布
①①	头靠 Headrest		1	Steel+PP+铁+PP
③	座垫 Seat	540*485*90	1	PP+Foam+Mesh PP+海绵+网布
④	椅脚330# Chair Base-330mm	330mm	1	PP+FG/PP+玻璃纤维
⑤	双手柄可躺托 Recliner Mechanism		1	Steel/铁
⑥	扶手-左 Armrest -Left		1	PP+FG/PP+玻璃纤维
⑦	扶手-右 Armrest -Right		1	PP+FG/PP+玻璃纤维
⑧	头靠手轮 Head on the handwheel		1	PP+FG/PP+玻璃纤维

扫一扫获取安装视频教程
Scan for installation video



第一步：扫码自动跳转林氏木业公众号页面
Step 1: Scan the code to automatically jump to the page of Linsy Official Accounts.

第二步：下拉页面至安装视频位置
Step 2: Pull down the page to the installation video location

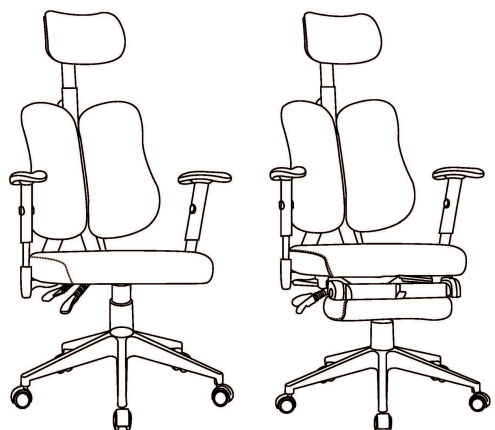

BY051-A无脚托

BY051-B有脚托

备注：2款产品说明书通用

BY051-A/B Computer Chair

安装方法/Installation method

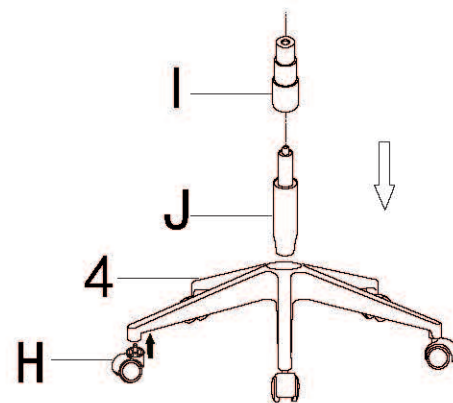

把椅轮H分别装入椅脚4的五个脚孔，再将气压棒J装入椅脚4的中心孔，最后套上防尘套I
 Install the gaming wheels H into the five holes of the chair base 4, then install the gas lift J into the center hole of the chair base 4, and finally put on the dustproof cover I

1

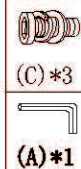

(C) *3

(A) *1

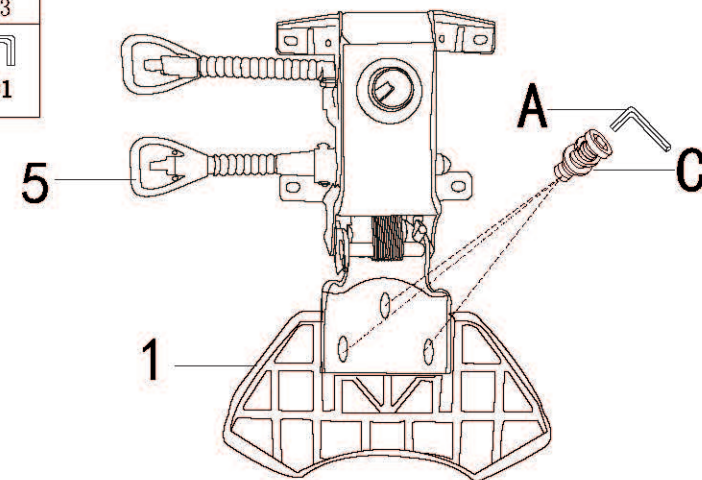

将靠背塑板与双手柄可躺托5孔位对准，使用五金C对准孔位锁紧固定
 The backrest plastic plate and the double handles can be reclined 5 holes to align, using hardware C to align the holes to lock and fix

2



(B) *4



(A) *1

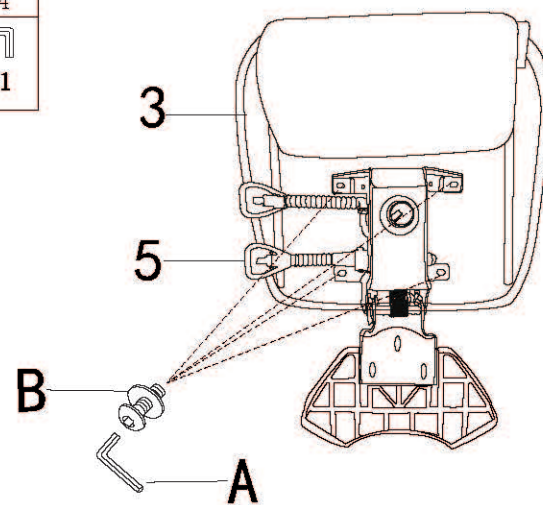

将双手柄可躺托5放置在坐垫3的中心位，使用五金B对准坐垫3的孔位
 The chassis 5 is placed in the center of the Cushion 3, and the hole of the cushion 3 is locked and fixed with hardware B

3



(D) *6



(A) *1

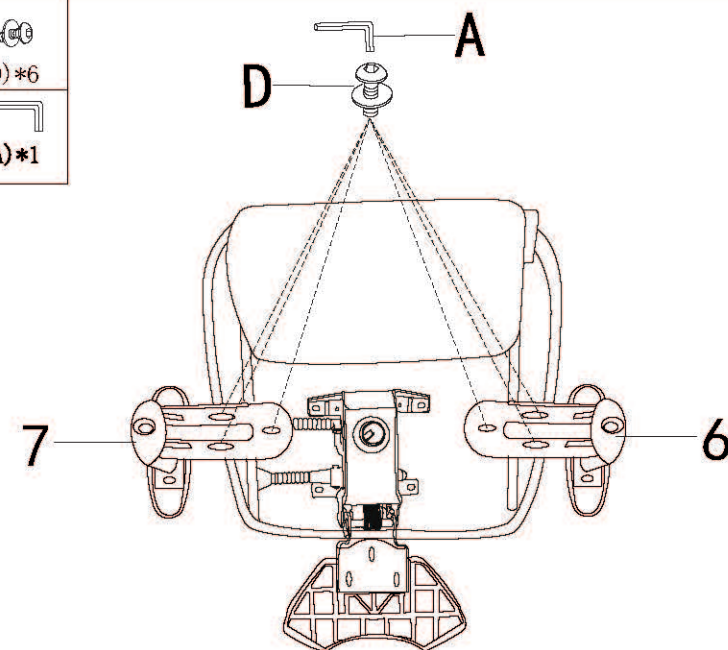

将座垫3用扶手5、6进行连接，使用五金D对准座垫3的孔位锁紧固定
 The seat Cushion 3 is connected with armrests 6 and 7 and the hole of the seat cushion 3 is locked and fixed with hardware D

4

BY051-A/B Computer Chair

安装方法/Installation method

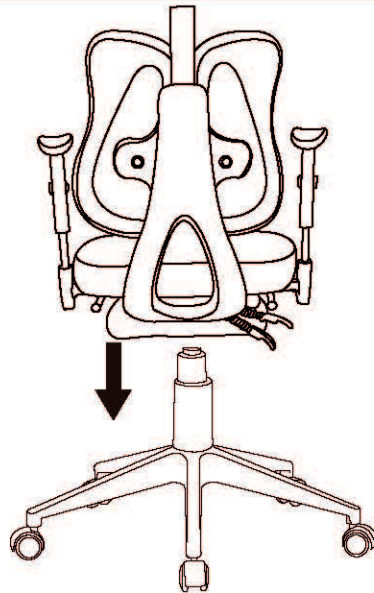

将气杆的顶端对准底盘的孔位对接，椅子下半部分按照完成
Align the top of the air rod to the hole of the chassis,
and the bottom half of the chair is finished

5



(G) *2

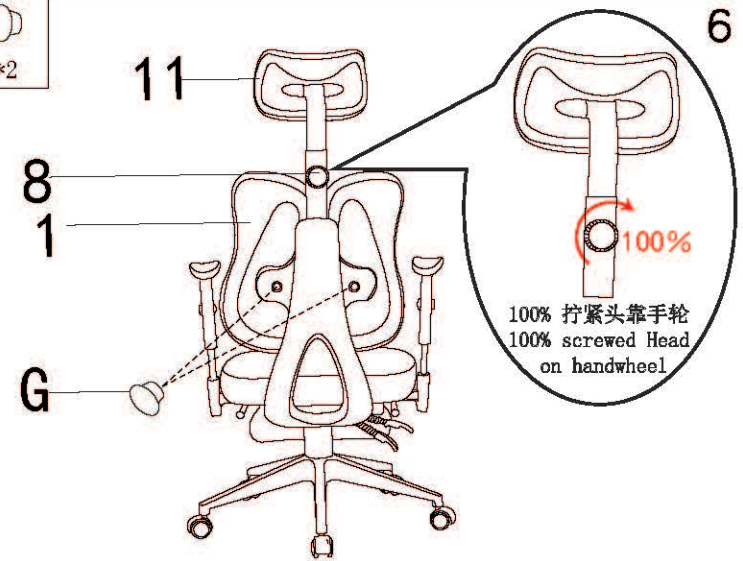

将头靠11插进头靠钢管，用头靠手轮8顺时针旋紧，再使用扣盖G扣住靠背孔位。
安装完成

Insert the head 11 into the head on the steel tube, turn the head on the handwheel 8
clockwise tight, and then use the G touch cover to touch the back hole. Installation
complete