

LINSY 林氏家居

五金表/Hardware list

部件表/Parts List

安装示意图/Assembly Instruction

产品名称 Model NO.	YZ1E-A 九斗柜
产品规格 Specification	1592*398*754mm
安装工具 Tool	安装人数 Installer

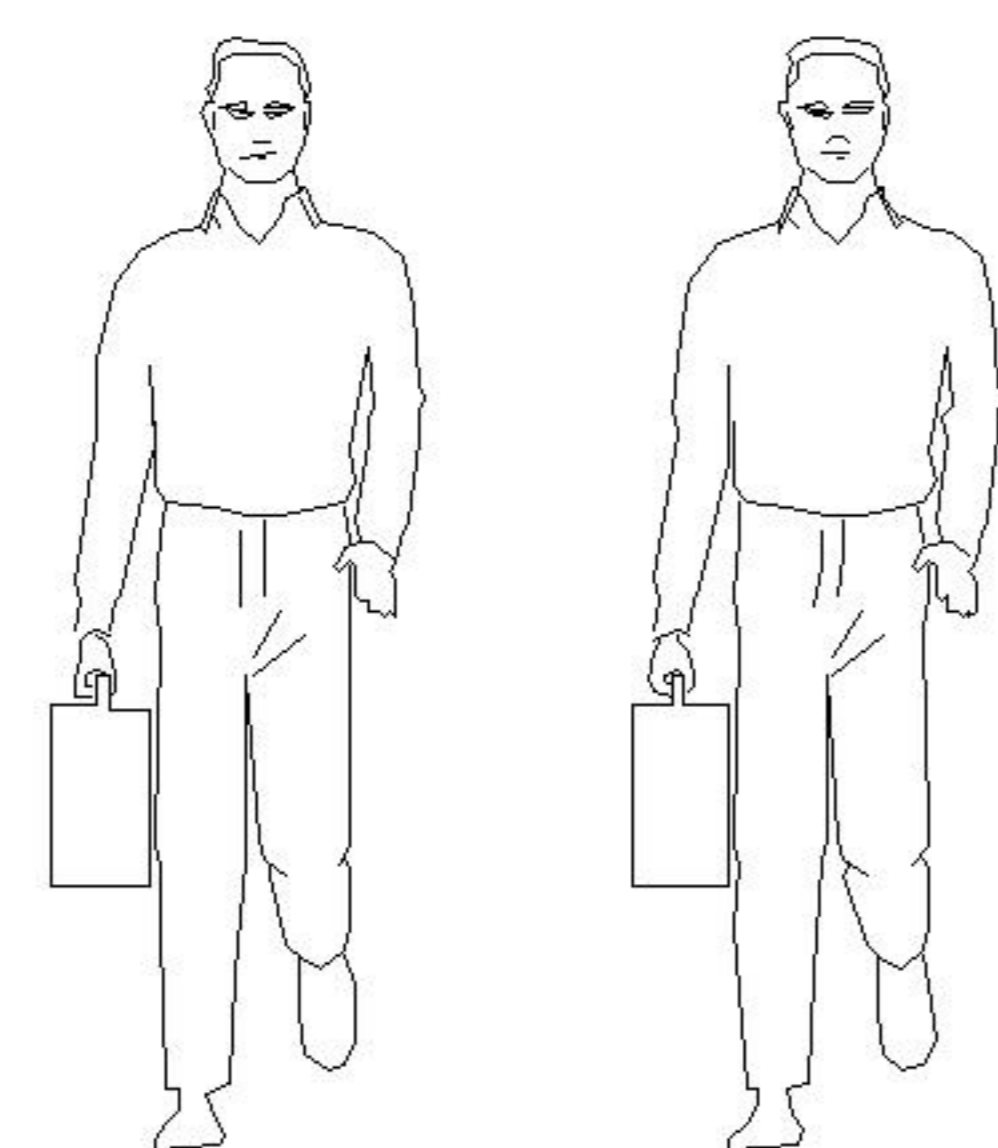
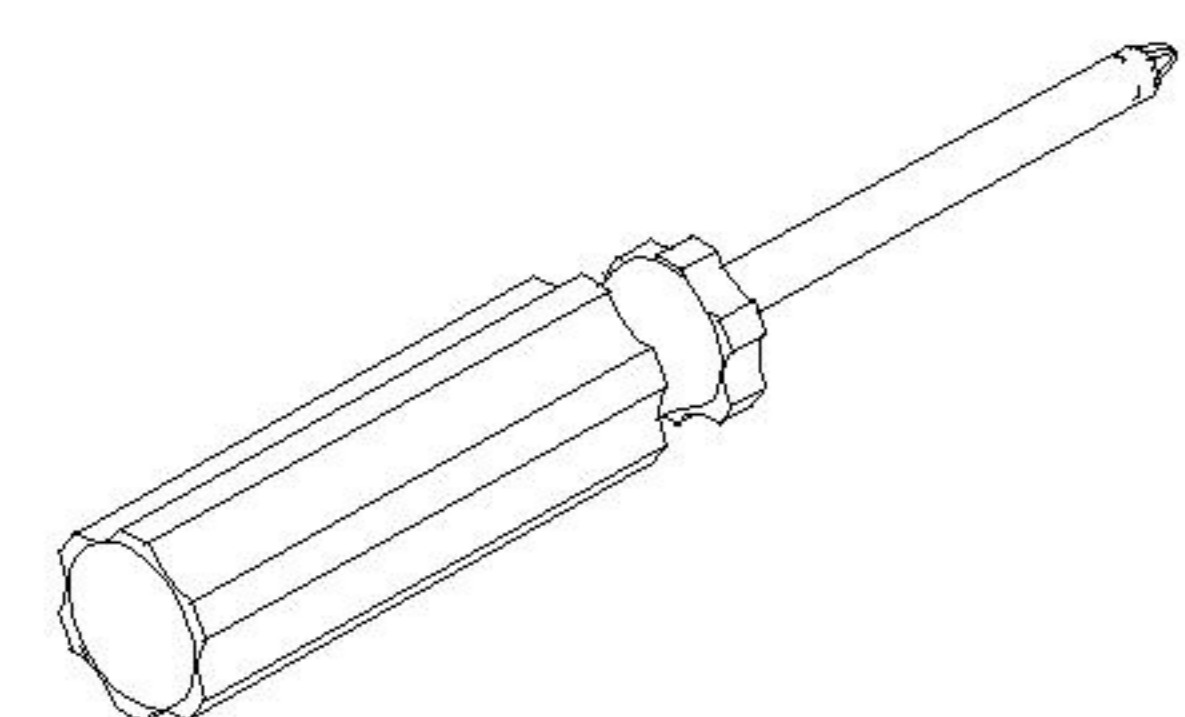

注：为保证设计效果，部分尺寸为定制尺寸，不影响使用。

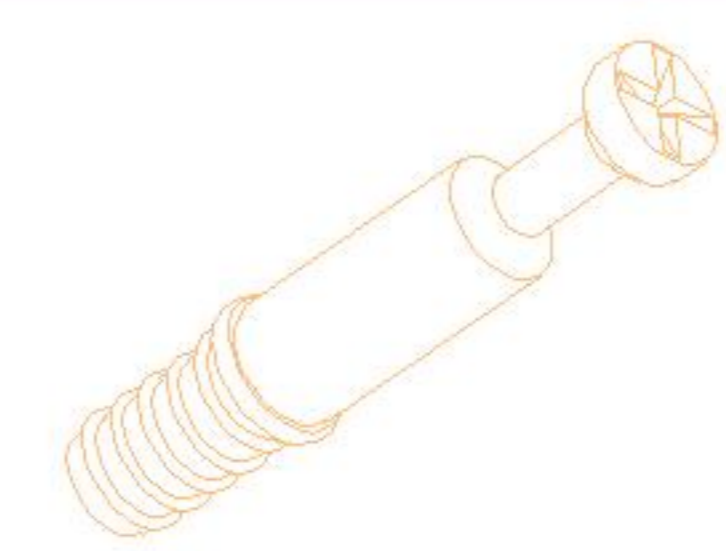
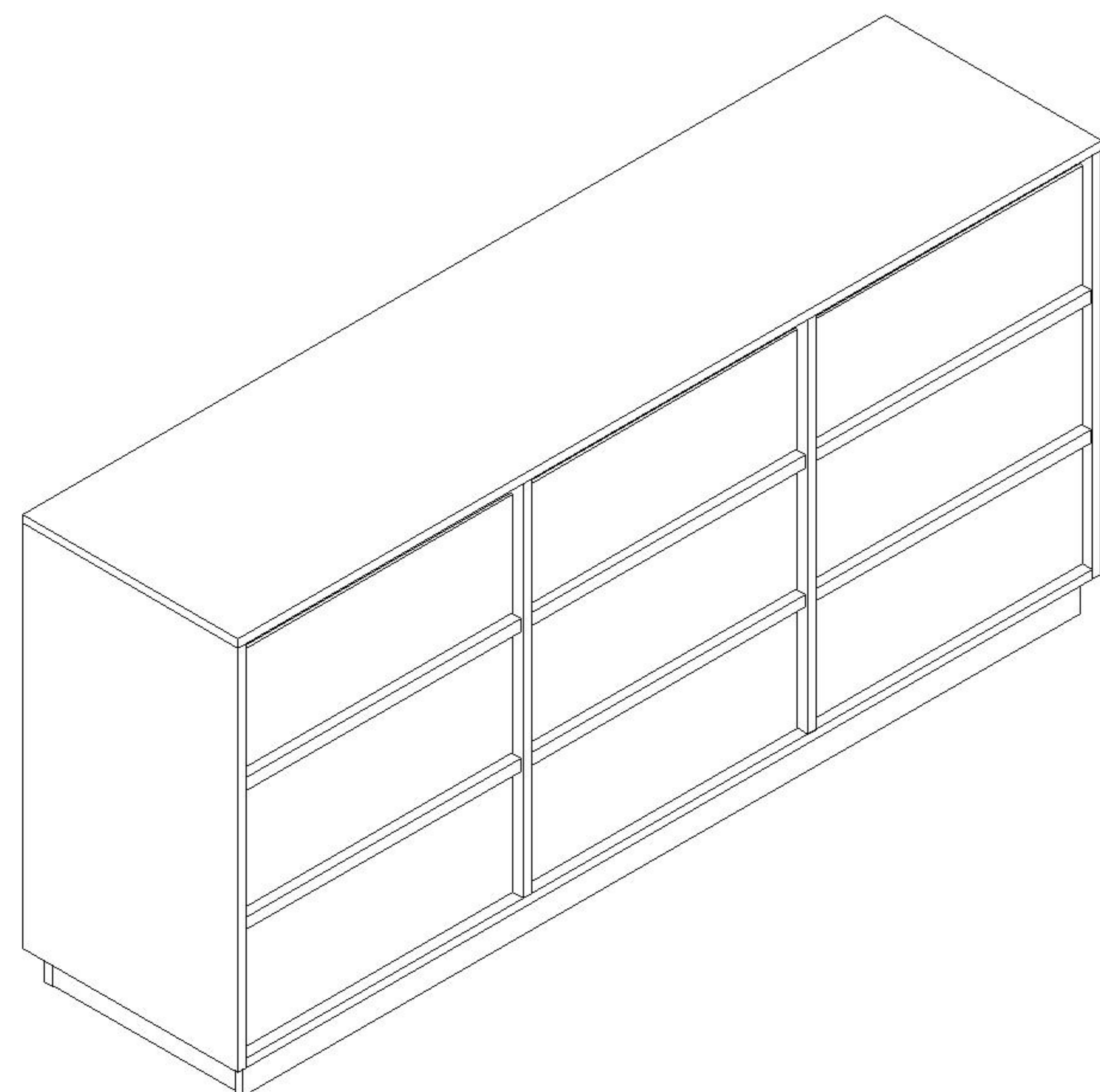

(A)*154
二合一螺杆
2-in-1-screw



(B)*166
大三合一锁饼
3-in-1 large lock

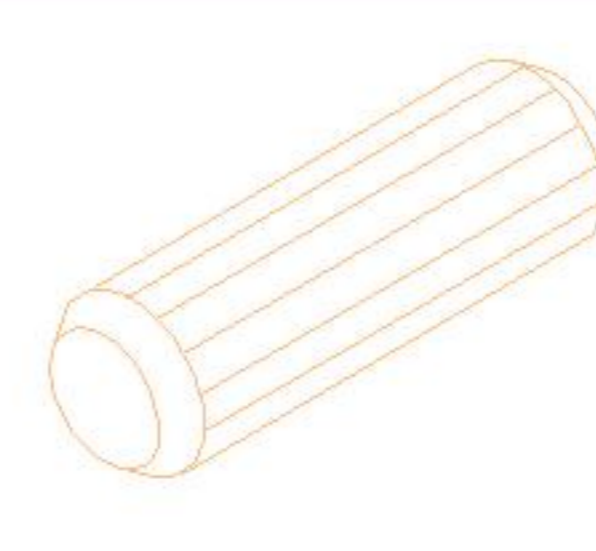

(C)*17
木榫Ø8x30mm
Wood tenon

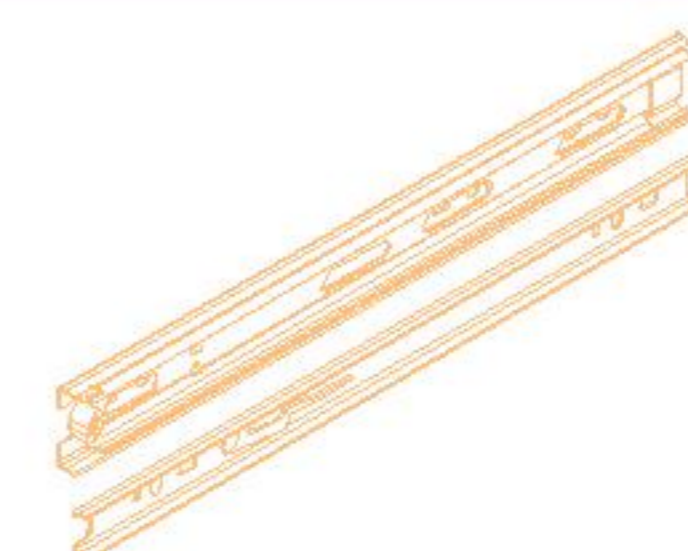

(D)*9
三节滚珠导轨10"
Three-section rail



(E)*6
双头三合一螺杆64
double-head
three-in-one screw

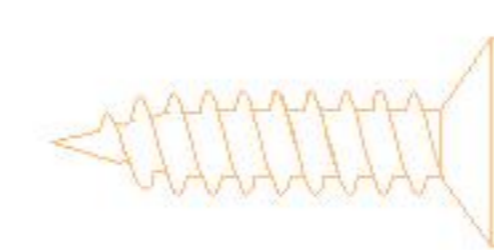

(F)*122
白攻螺丝M3.5*12mm
Tapping screw

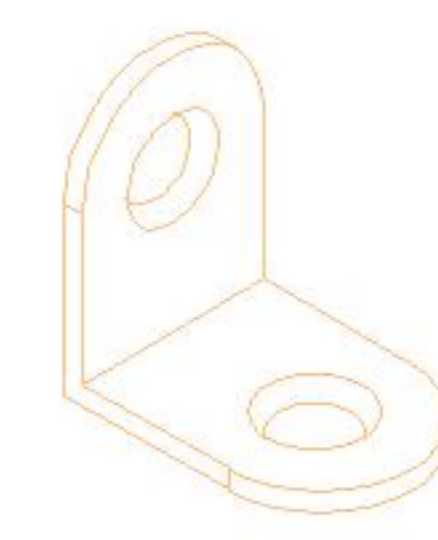

(G)*4
角码-(30*30*16mm)L型
Corner code

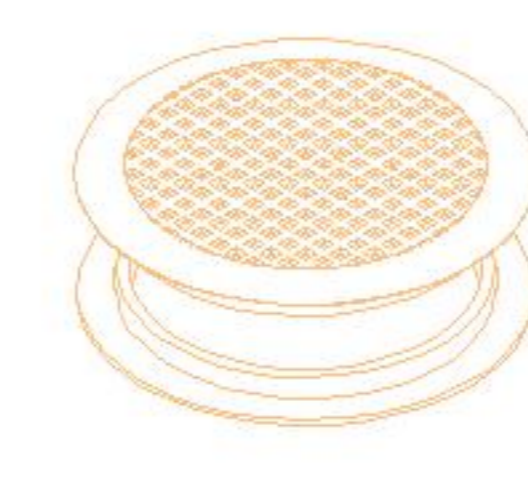

(H)*3
透气孔盖-白色
Breathable cover

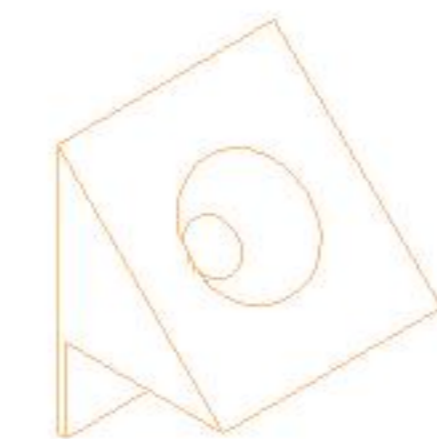

(I)*15
背板扣
White buckle

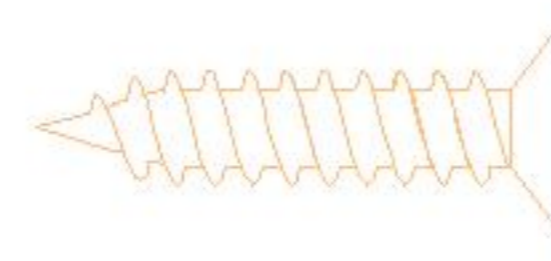

(J)*15
白攻螺丝M3.5*16mm
Tapping screw



(K)*1
夹板条 L=1559mm
Splint strip



(L)*12
灰色毛毡脚垫(Φ16*3mm)
Foot pad

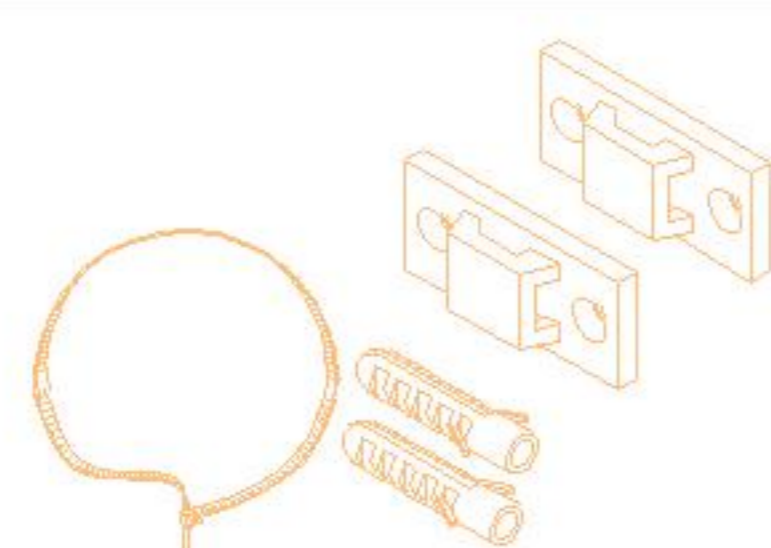

(M)*1
家具防倒器-白色
Anti-fall device

编号NO.	名称Name	规格(mm) Specification	数量QTY	材质Material
①	面板Top panel	1592*398*15	1	刨花板 Particle board
②	底板Bottom board	1560*397*15	1	刨花板 Particle board
③	左侧板Side board(L)	678*397*15	1	刨花板 Particle board
④	右侧板Side board(R)	678*397*15	1	刨花板 Particle board
⑤	中侧板Middle side board	663*375*15	2	刨花板 Particle board
⑥	上拉条Top brace	510*58*15	3	刨花板 Particle board
⑦	下拉条Bottom brace	510*58*15	3	刨花板 Particle board
⑧	前后脚条Front and rear foot strips	1542*58*15	2	刨花板 Particle board
⑨	侧脚条Side foot strip	337*58*15	4	刨花板 Particle board
⑩	拉手Handle	506*30*20	6	橡胶木Rubber wood
⑪	上抽屉面板Upper drawer's panel	506*190*15	3	刨花板 Particle board
⑫	上抽屉侧板Upper drawer side panel	295*110*15	6	刨花板 Particle board
⑬	上抽屉后板Upper drawer's back board	484*110*15	3	刨花板 Particle board
⑭	下抽屉面板Bottom drawer's panel	506*206*15	6	刨花板 Particle board
⑮	下抽屉侧板Lower drawer side panel	295*142*15	12	刨花板 Particle board
⑯	下抽屉后板Down drawer's back board	484*142*15	6	刨花板 Particle board
⑰	抽屉底板Drawer's Bottom board	464*305*5	9	纤维板Fiberboard
⑱	背板1Back board 1	1570*335*5	1	纤维板Fiberboard
⑲	背板2Back board 2	1570*335*5	1	纤维板Fiberboard

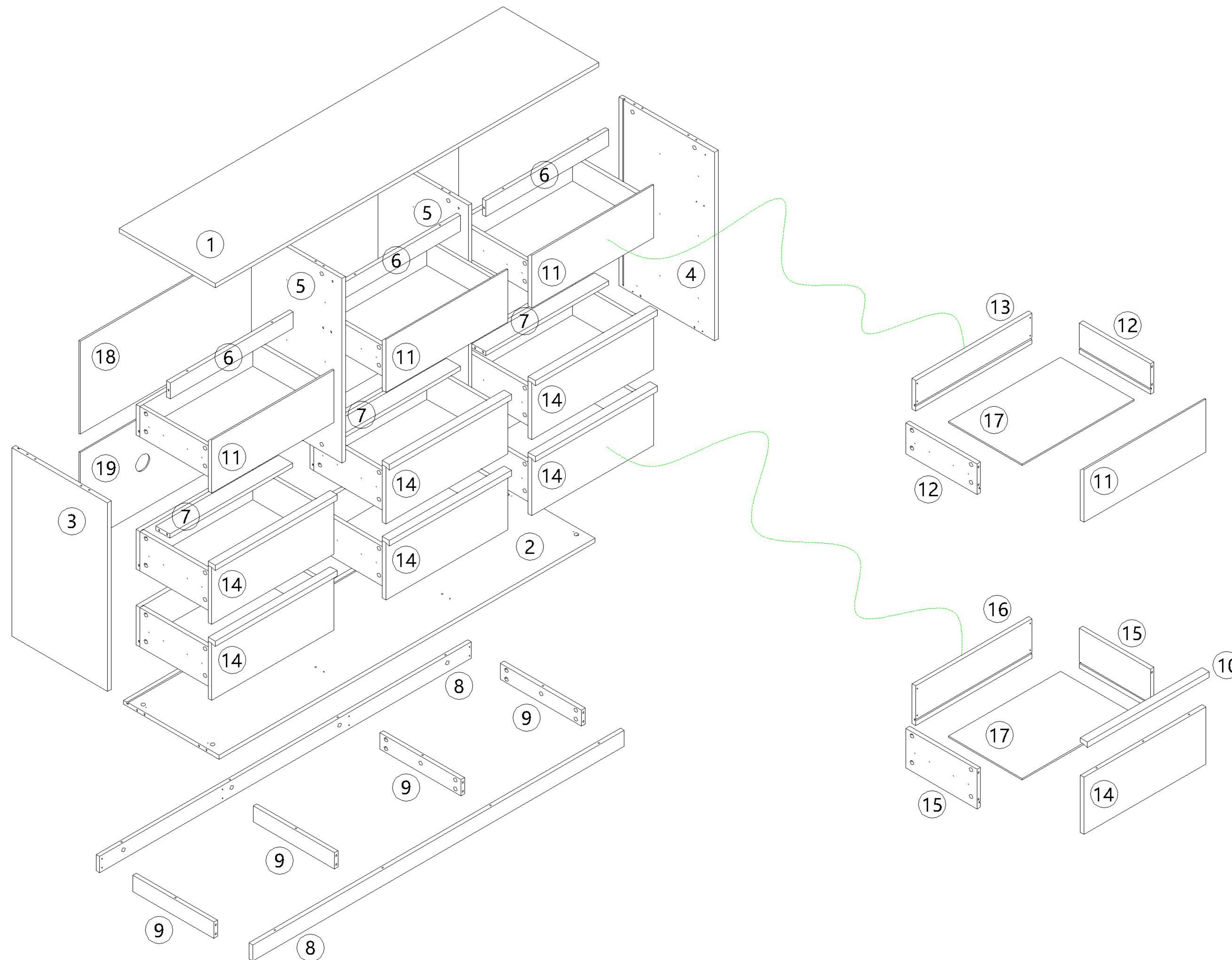

编号NO.	名称Name
①	面板Top panel
②	底板Bottom board
③	左侧板Side board(L)
④	右侧板Side board(R)
⑤	中侧板Middle side board
⑥	上拉条Top brace
⑦	下拉条Bottom brace
⑧	前后脚条Front and rear foot strips
⑨	侧脚条Side foot strip
⑩	拉手Handle
⑪	上抽屉面板Upper drawer's panel
⑫	上抽屉侧板Upper drawer side panel
⑬	上抽屉后板Upper drawer's back board
⑭	下抽屉面板Bottom drawer's panel
⑮	下抽屉侧板Lower drawer side panel
⑯	下抽屉后板Down drawer's back board
⑰	抽屉底板Drawer's Bottom board
⑱	背板1Back board 1
⑲	背板2Back board 2

YZ1E-A 九斗柜

安装方法/
Installation method

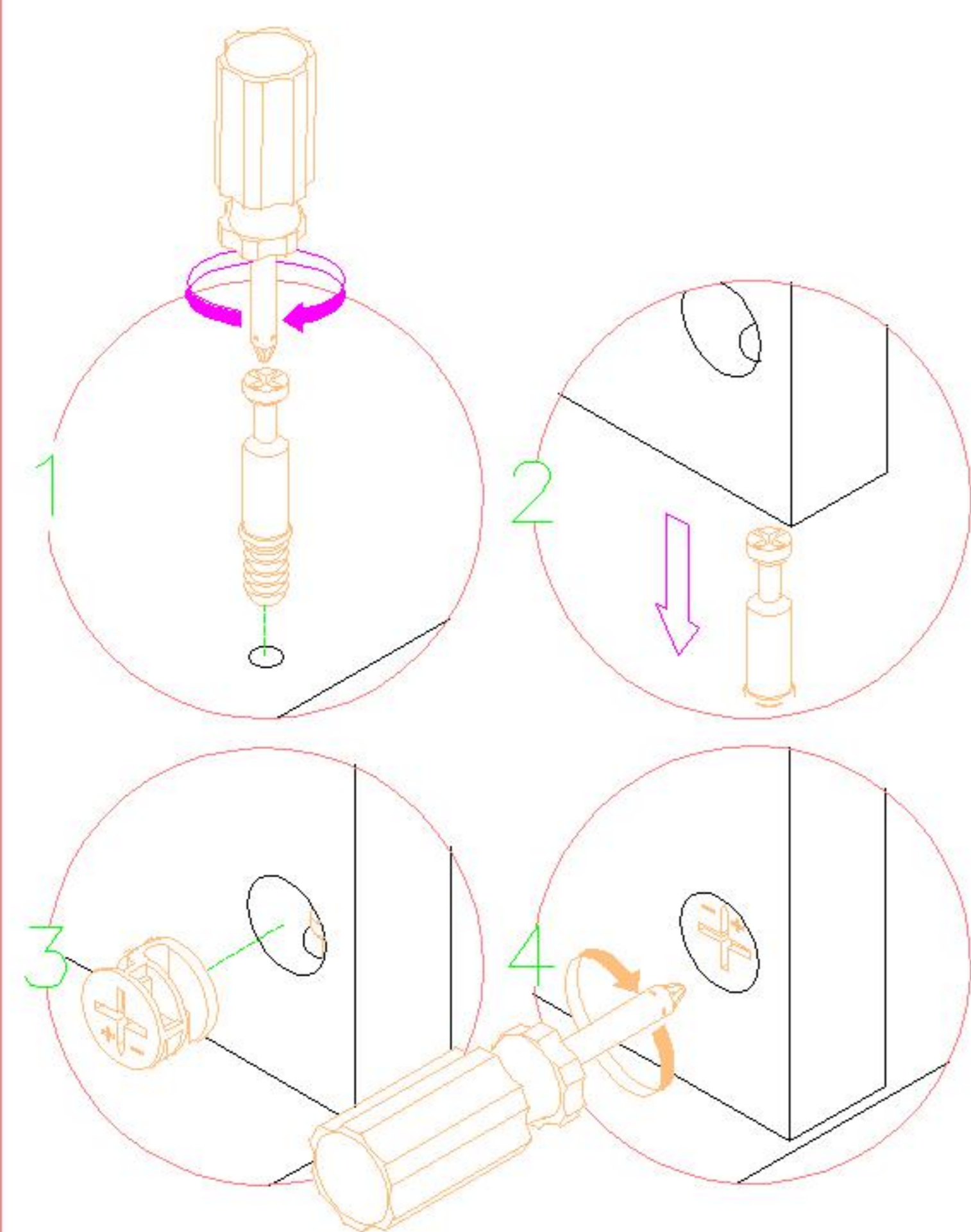

二合一 two-in-one

阀门开关(下压为开)
Valve switch (press down to open)

前 Forward ↓ 后 Back



主轨 Main track

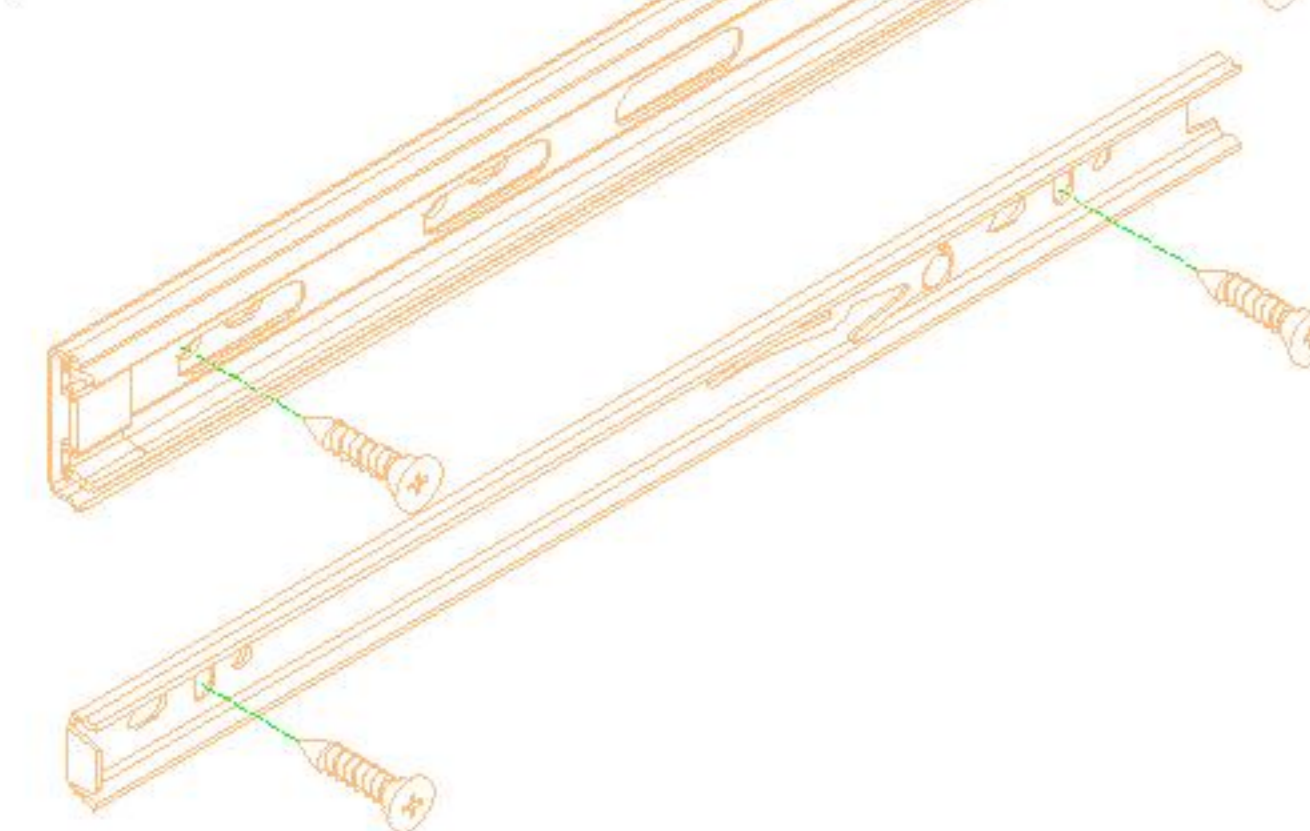

三节滚珠导轨-10"
Three-section rail

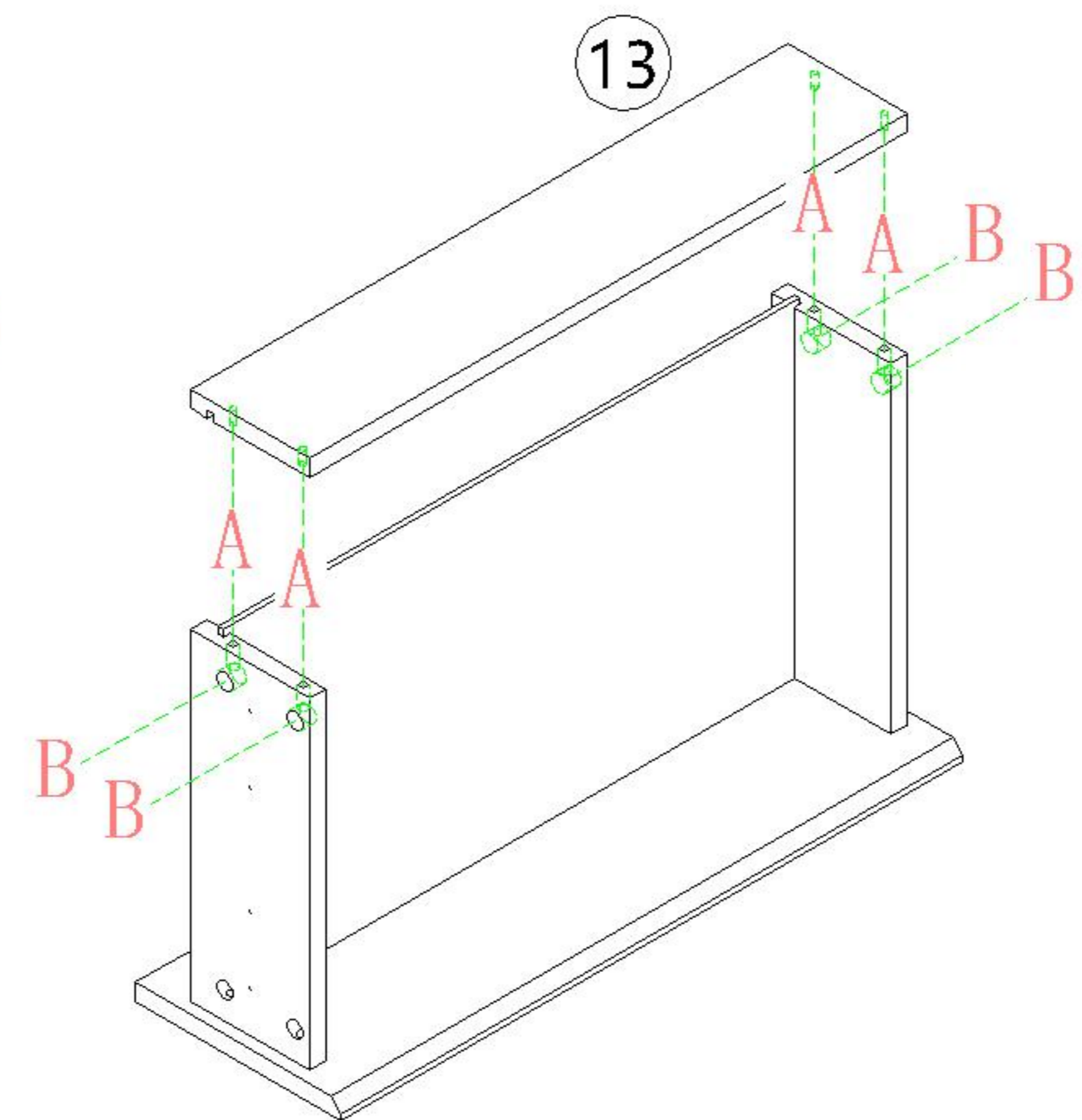
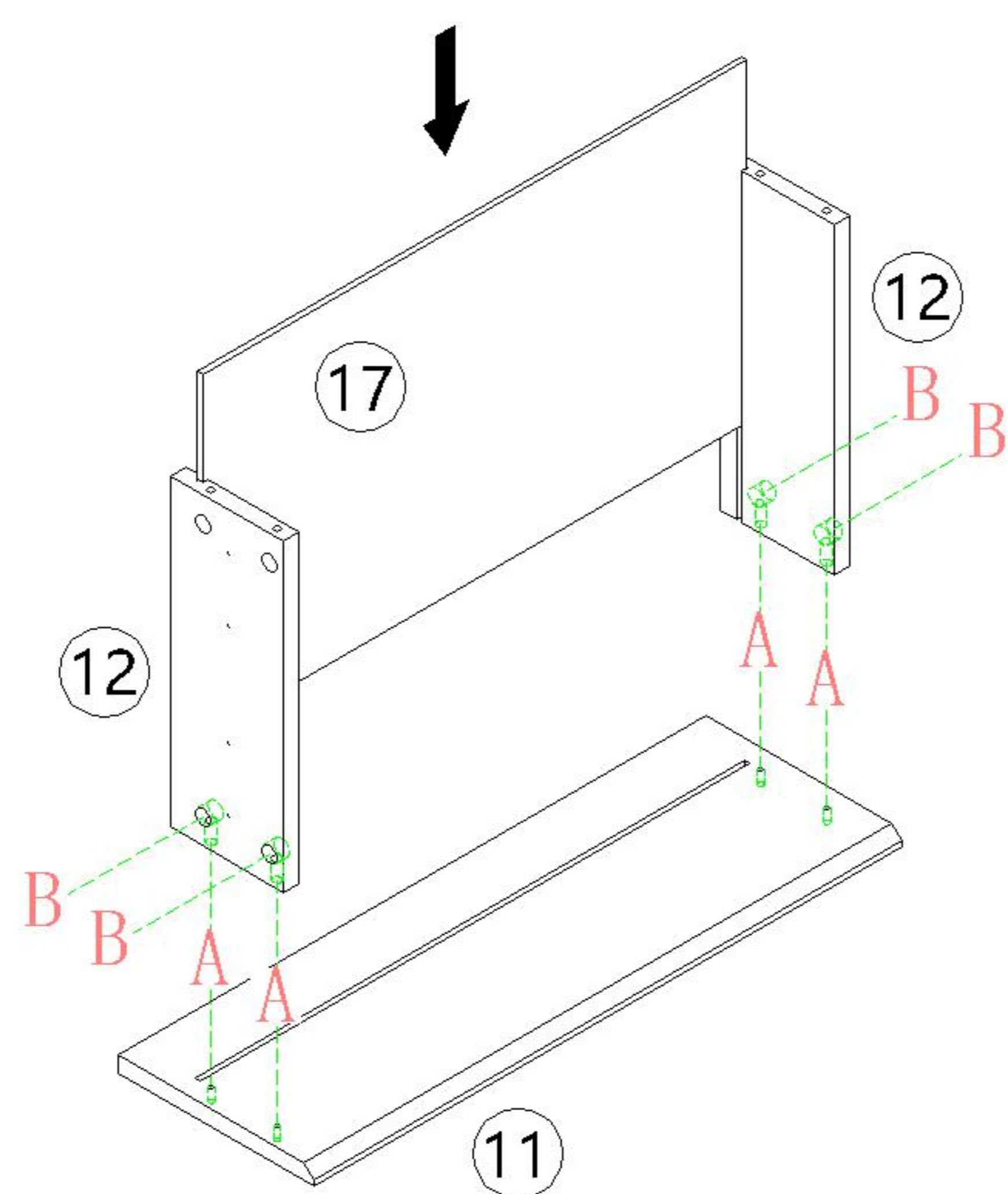
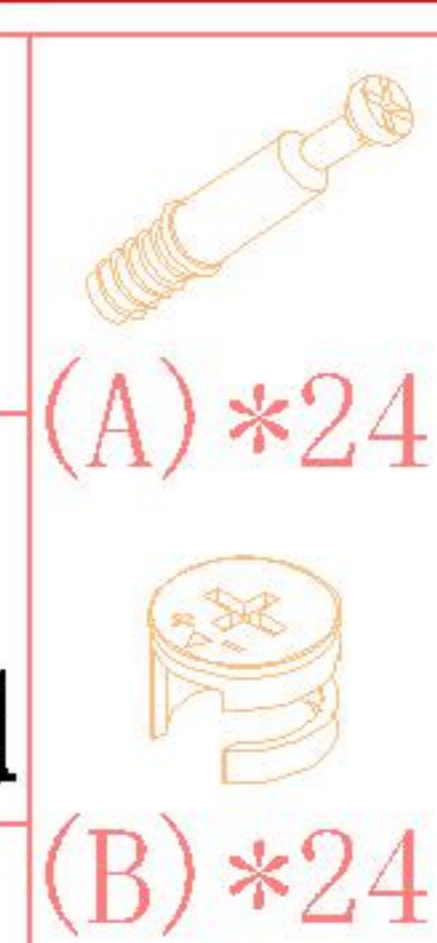

× 3

1

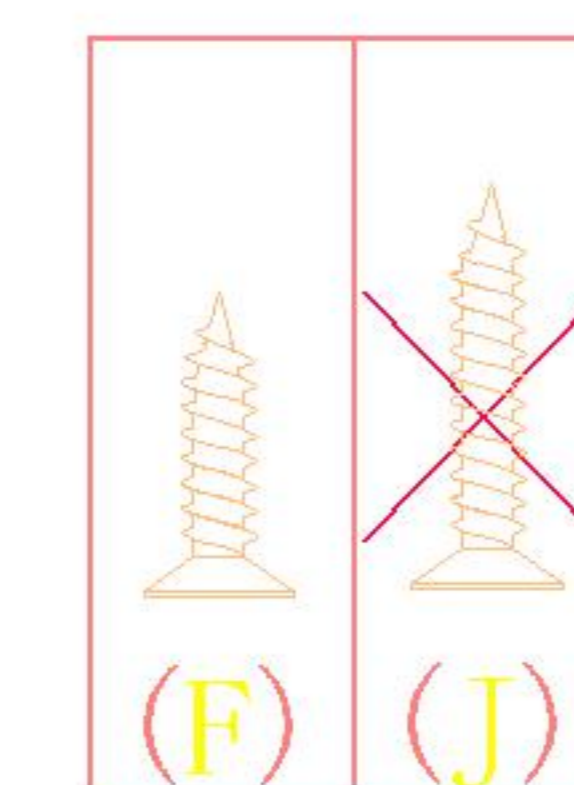
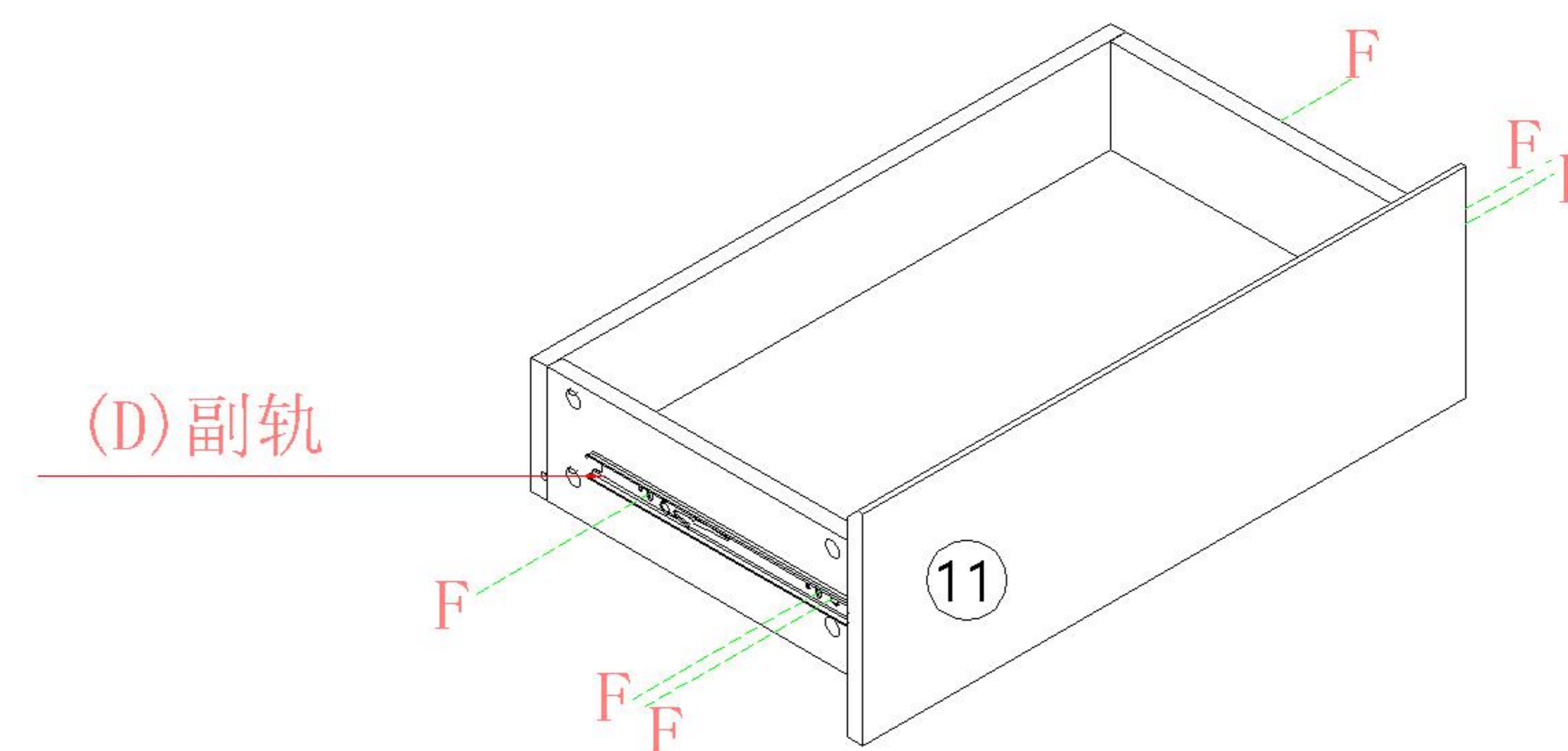
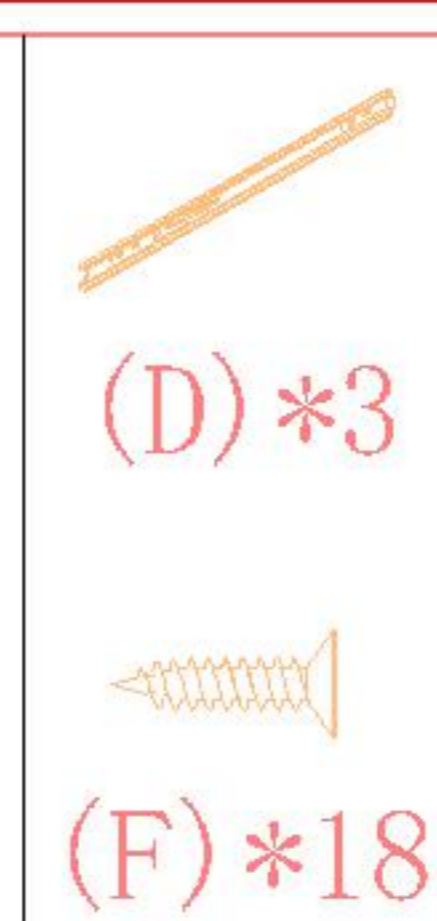

× 3

2

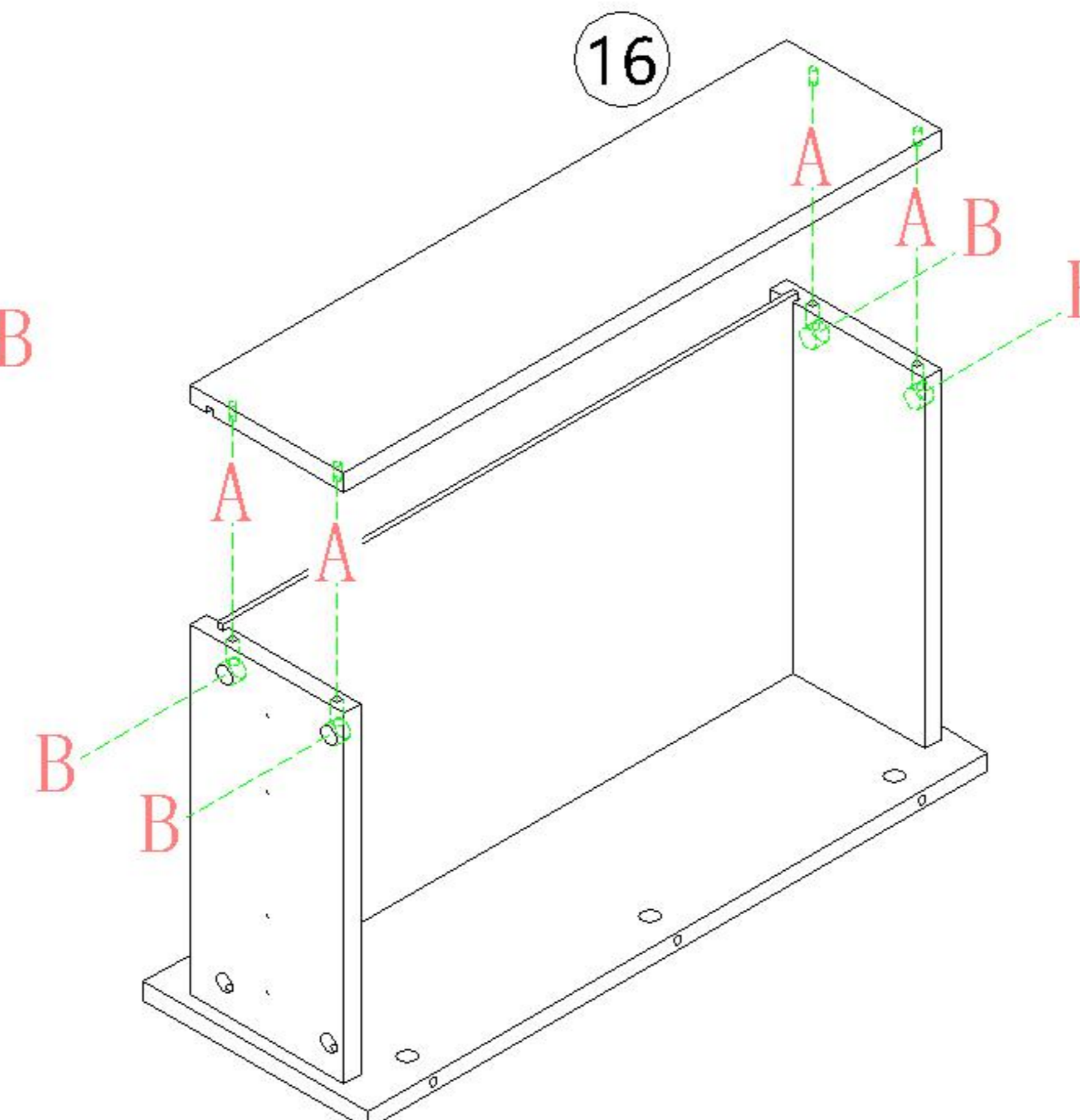
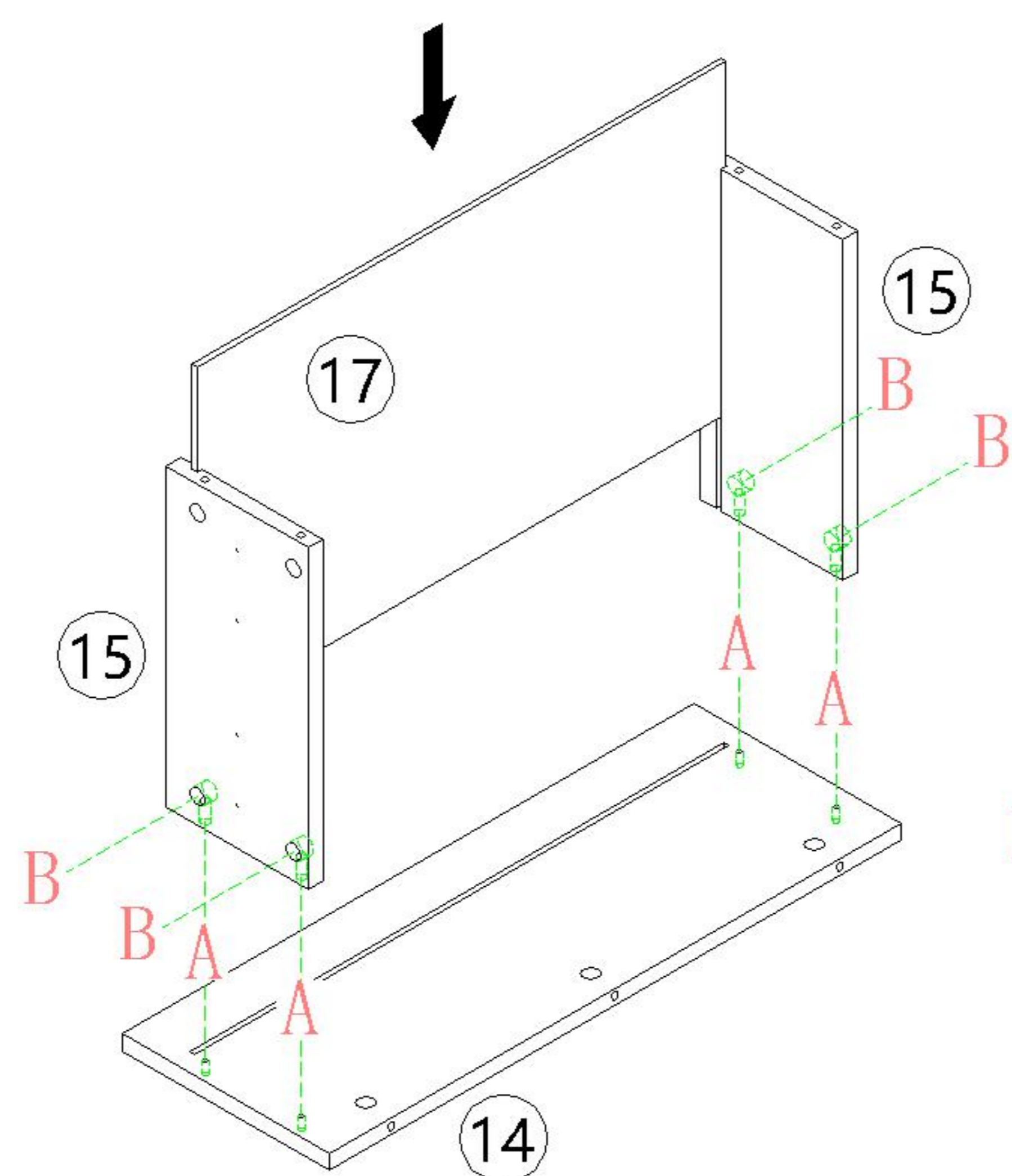

× 6

3

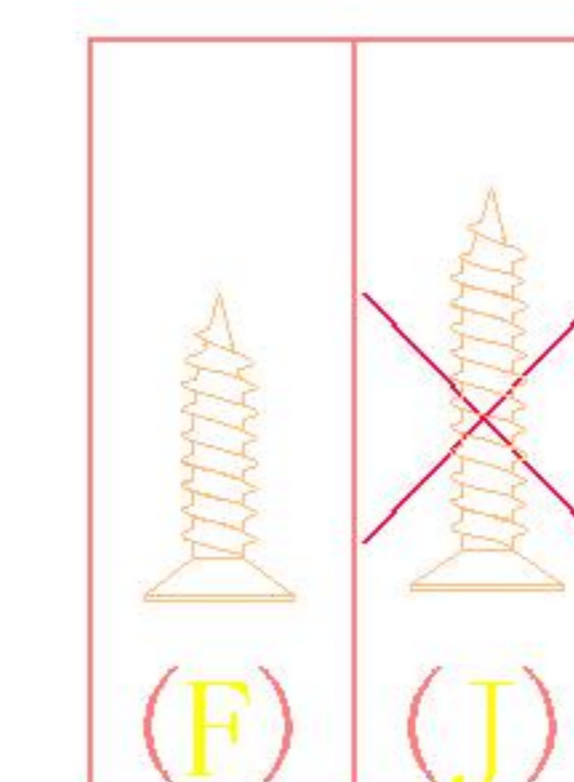
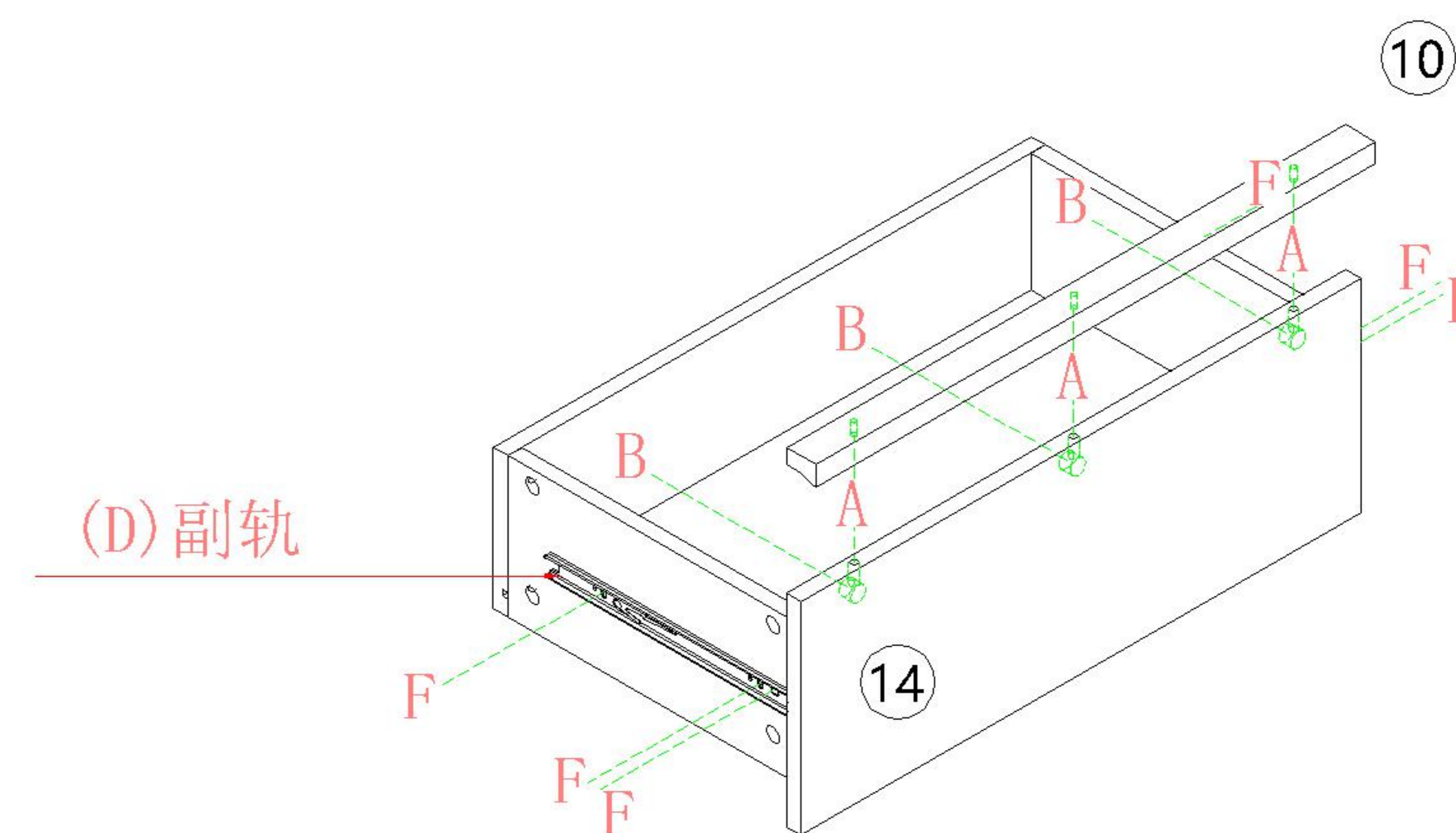
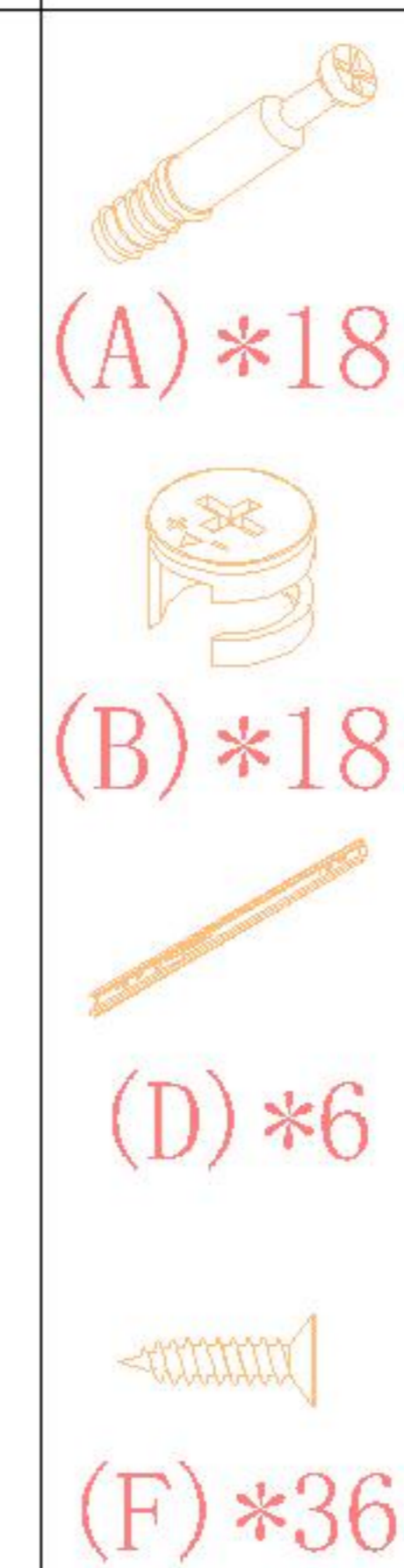

× 6

4

YZ1E-A 九斗柜

安装方法/
Installation method

1 阀门开关(下压为开)
Valve switch
(press down to open)

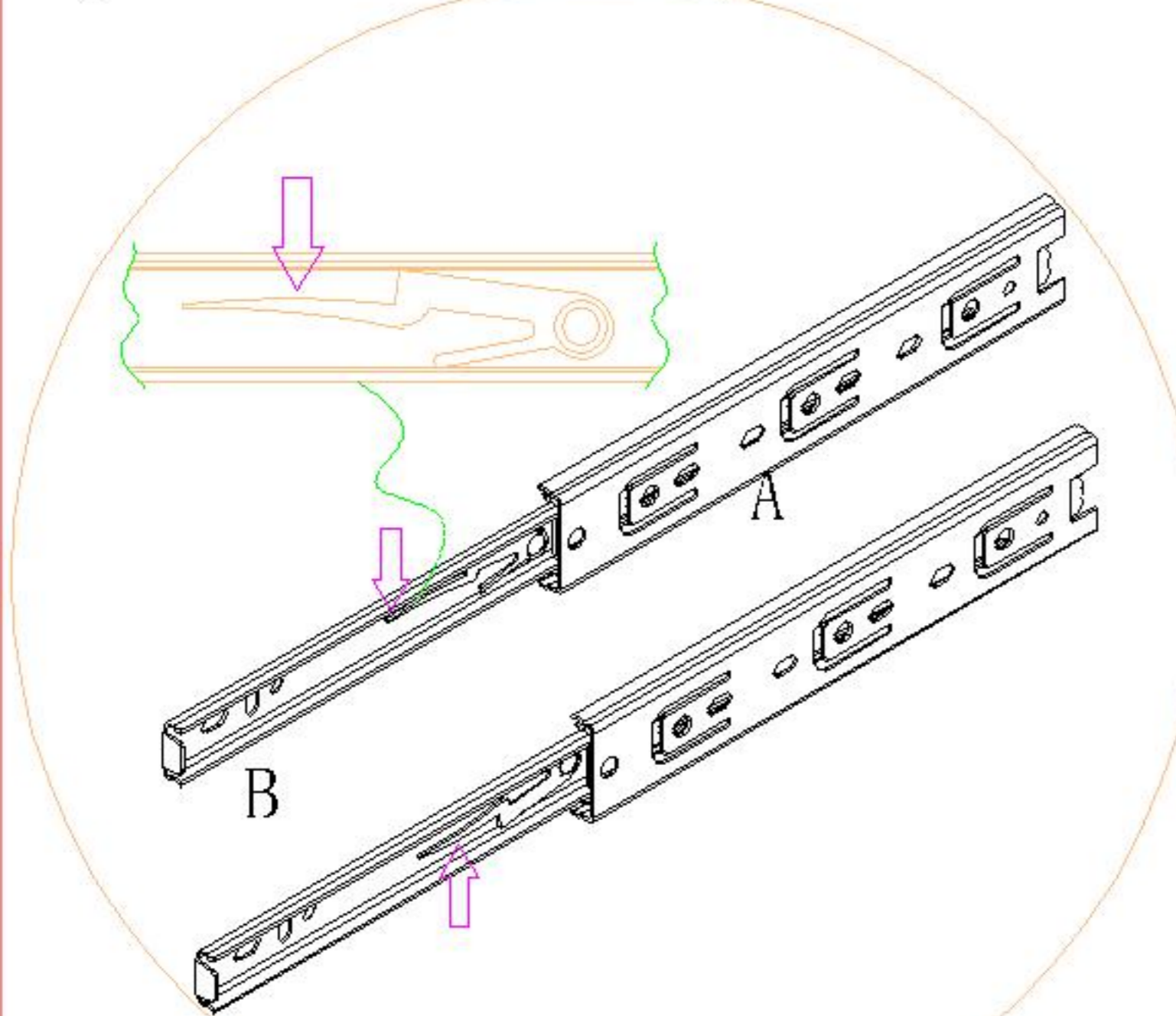

注: 先将A与B拆下来
Note: remove a and B first

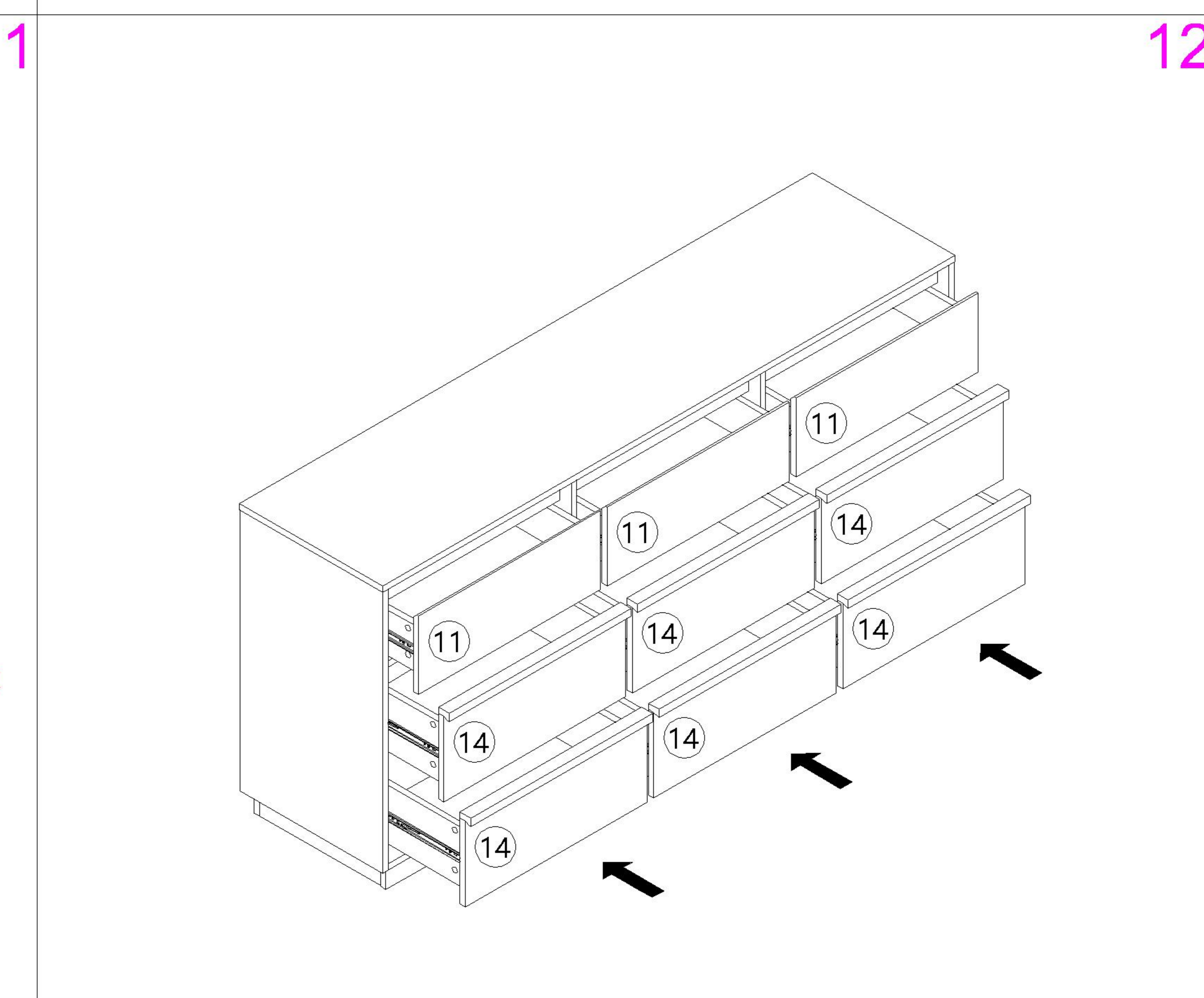
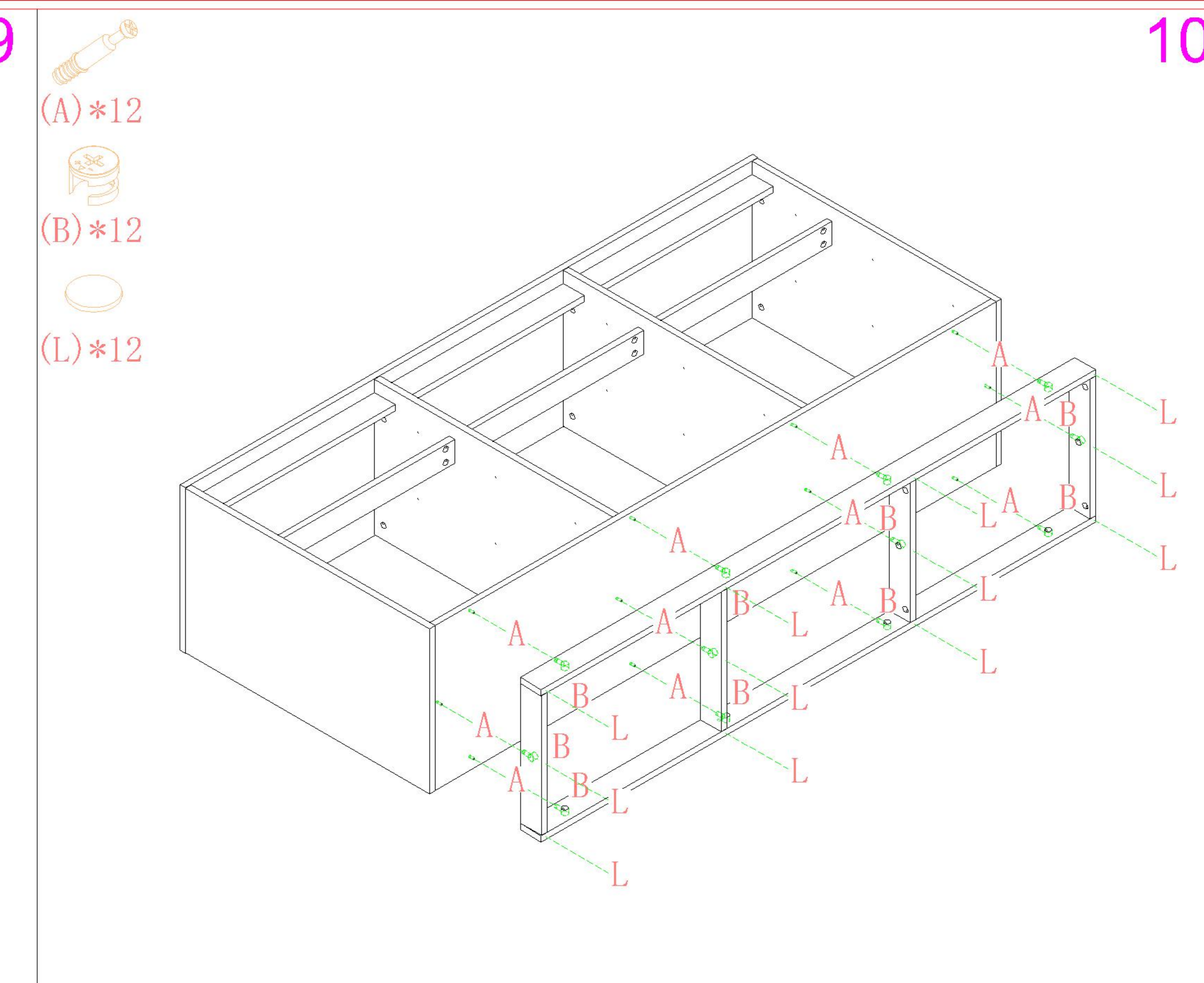
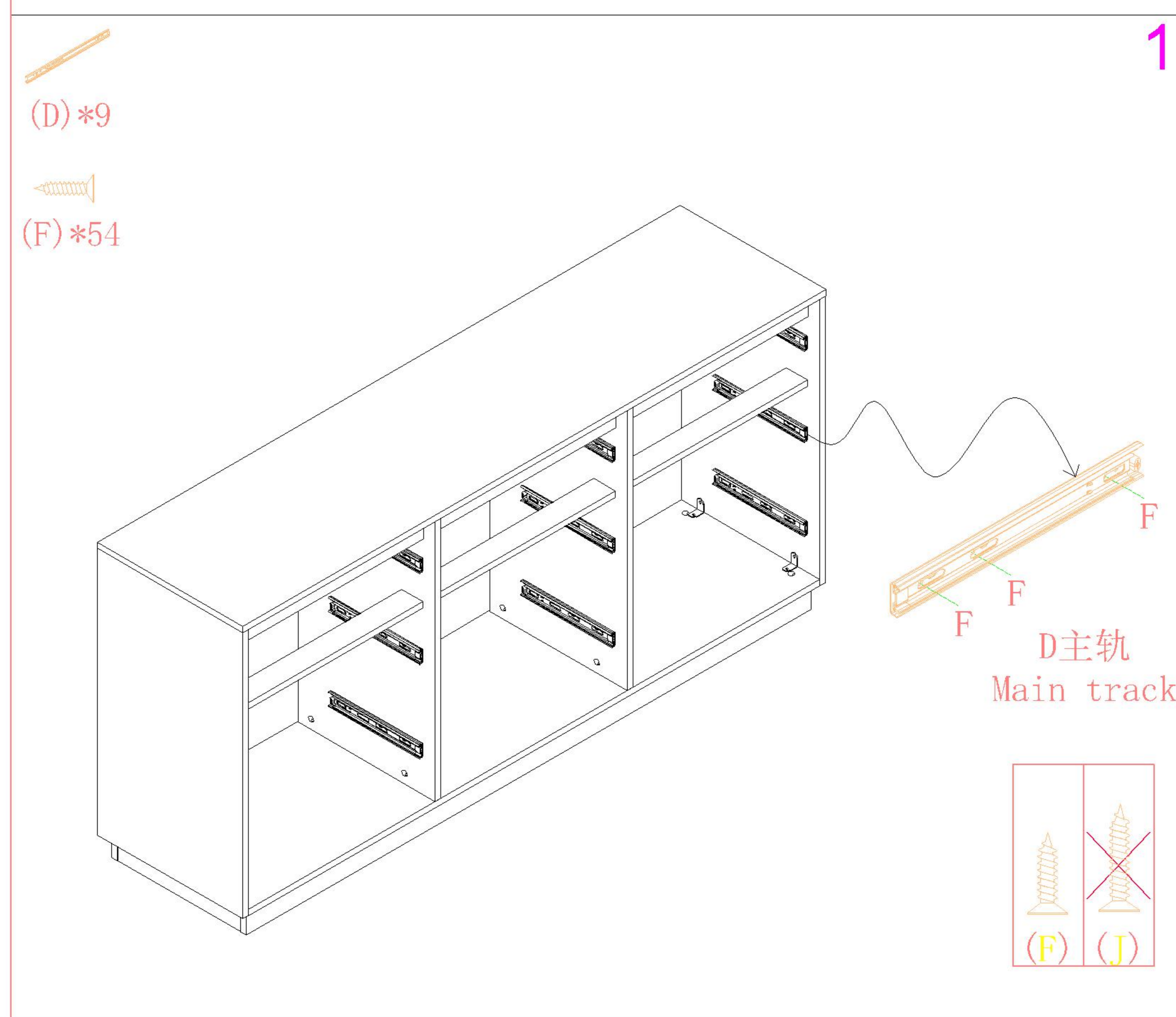
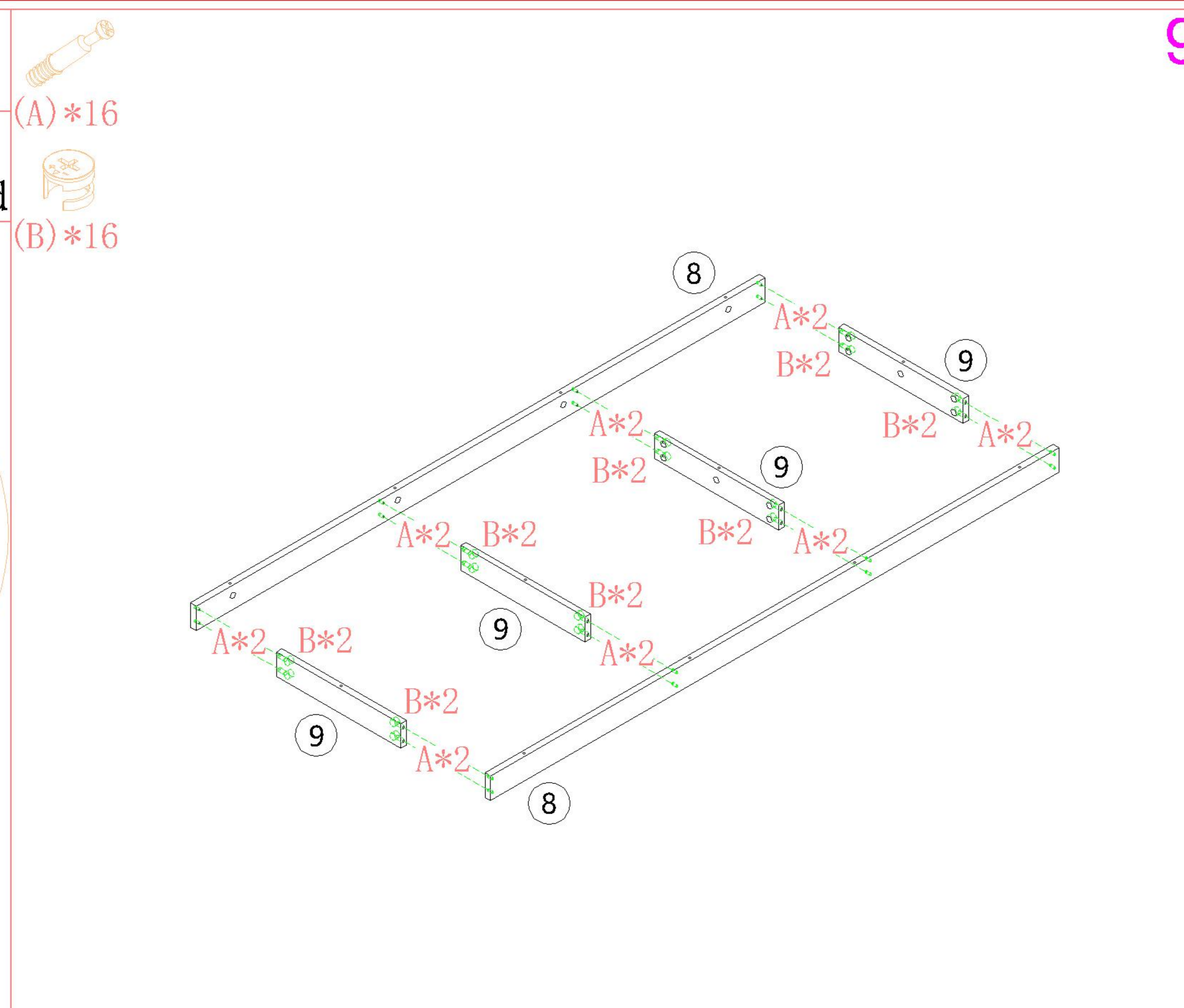
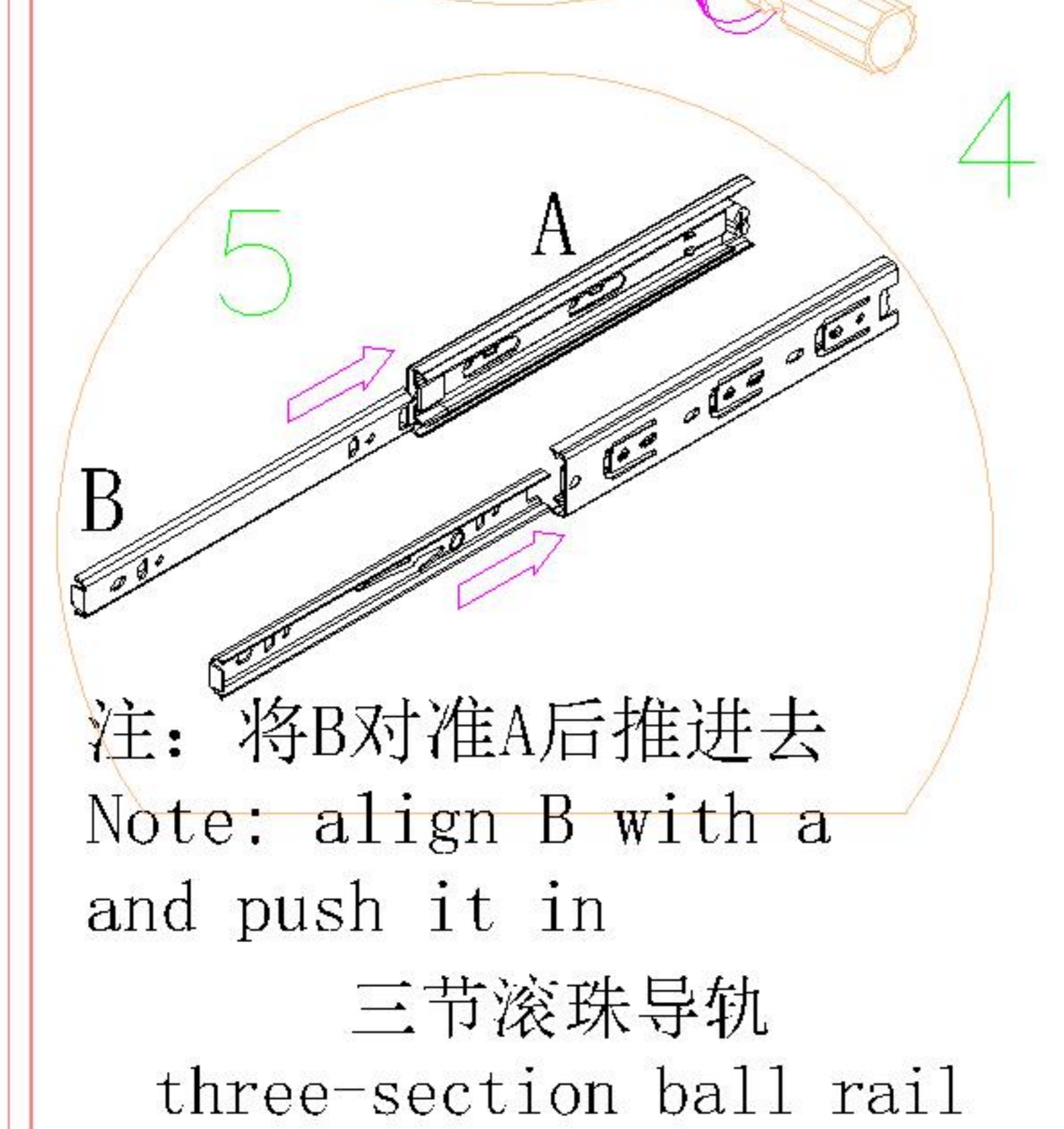
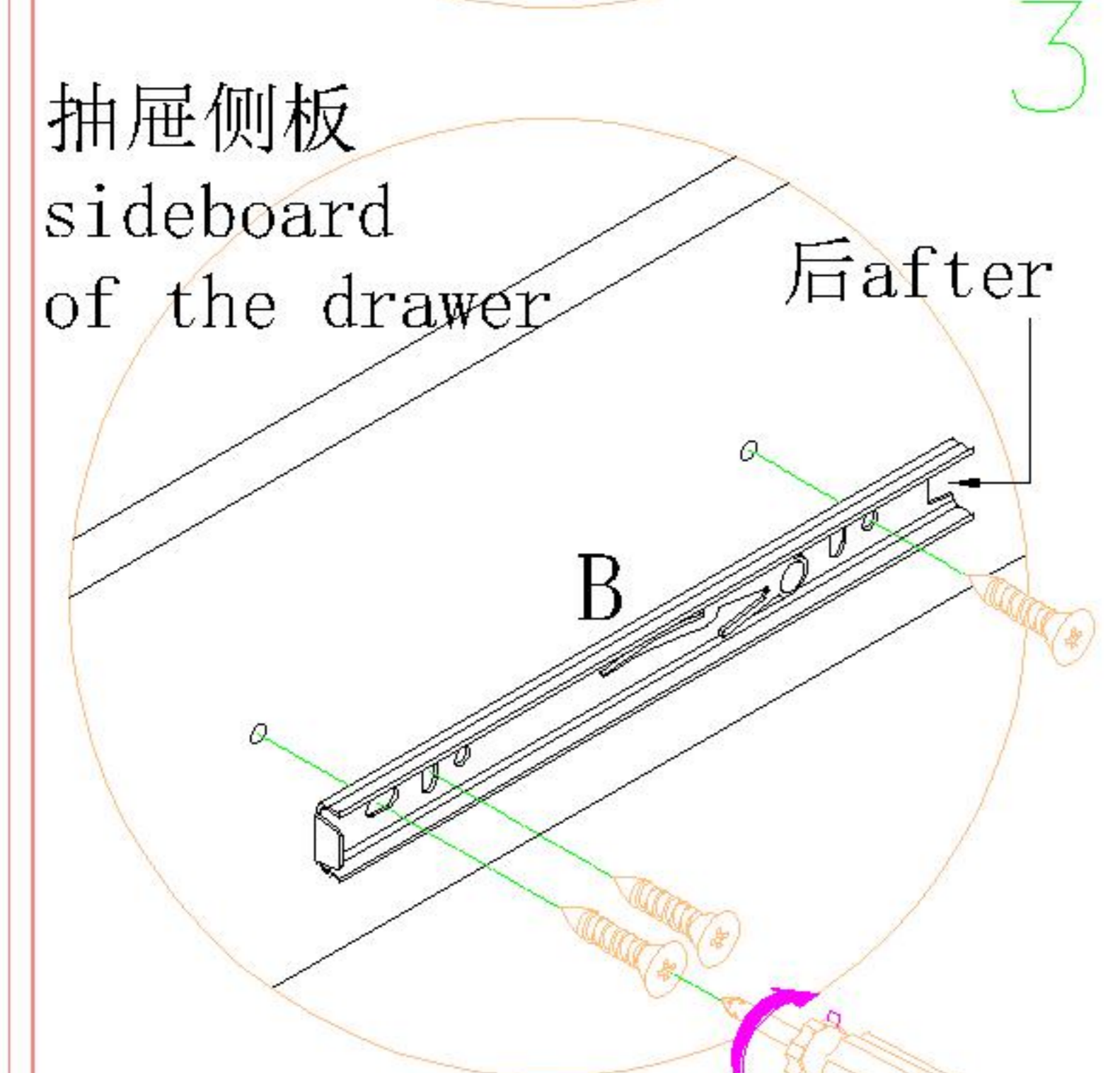
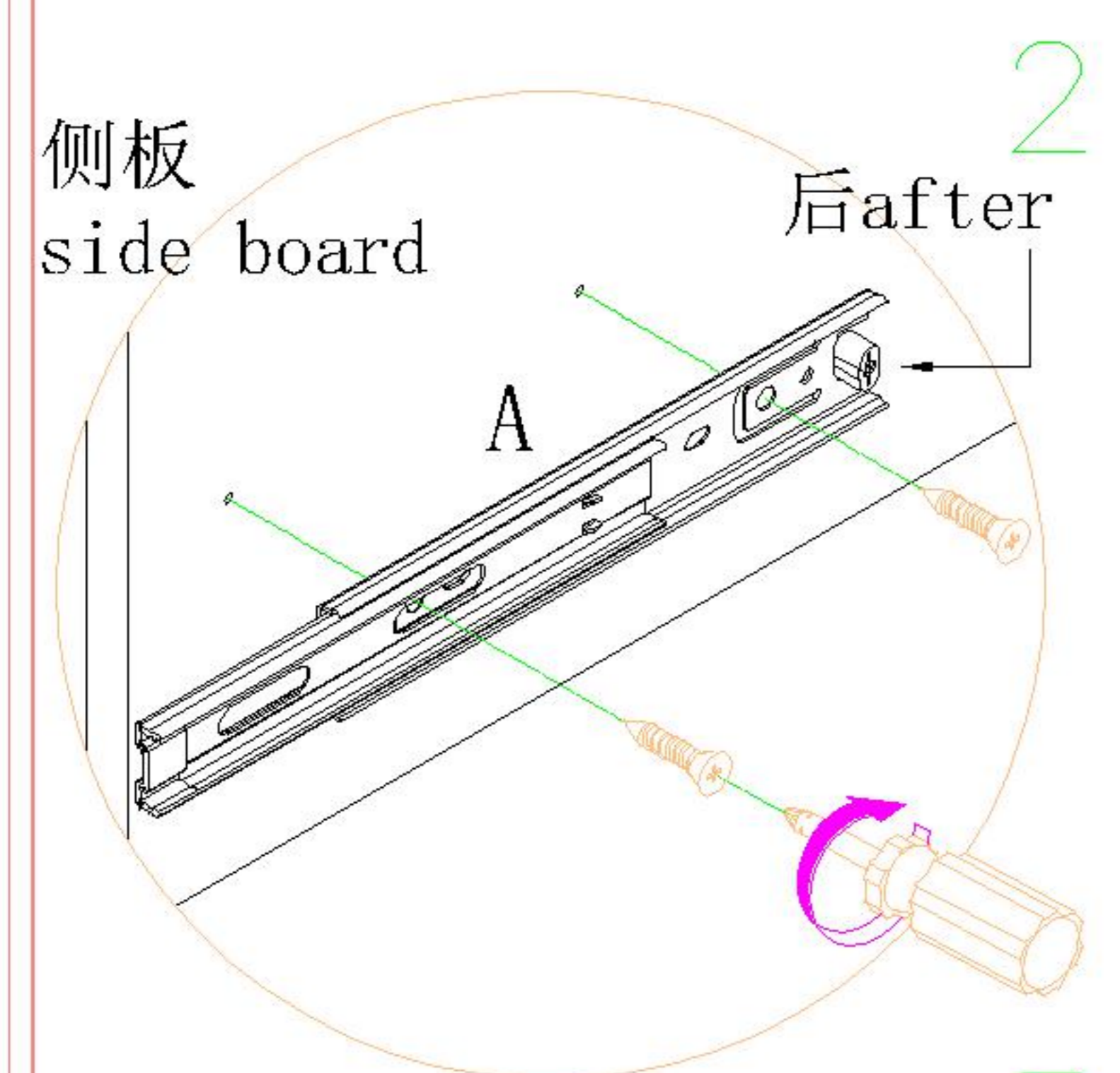

YZ1E-A 九斗柜

安装方法/
Installation method

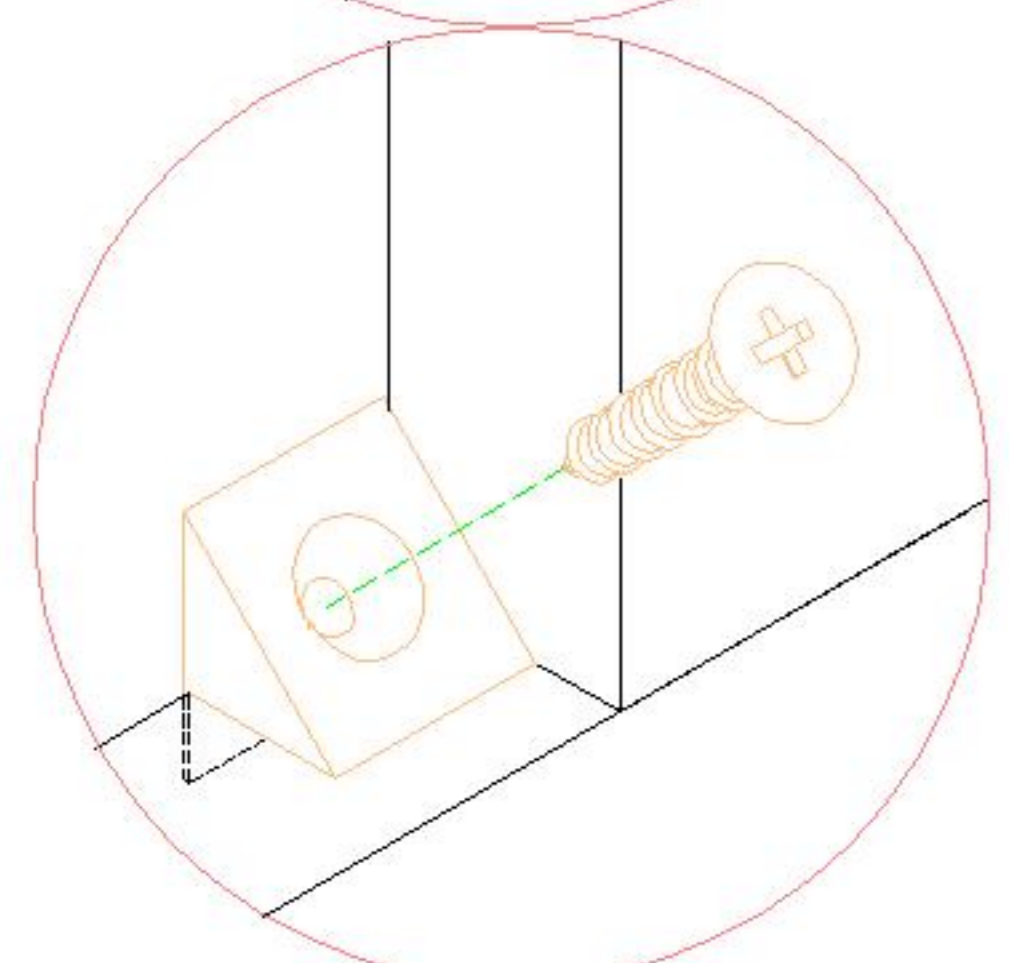
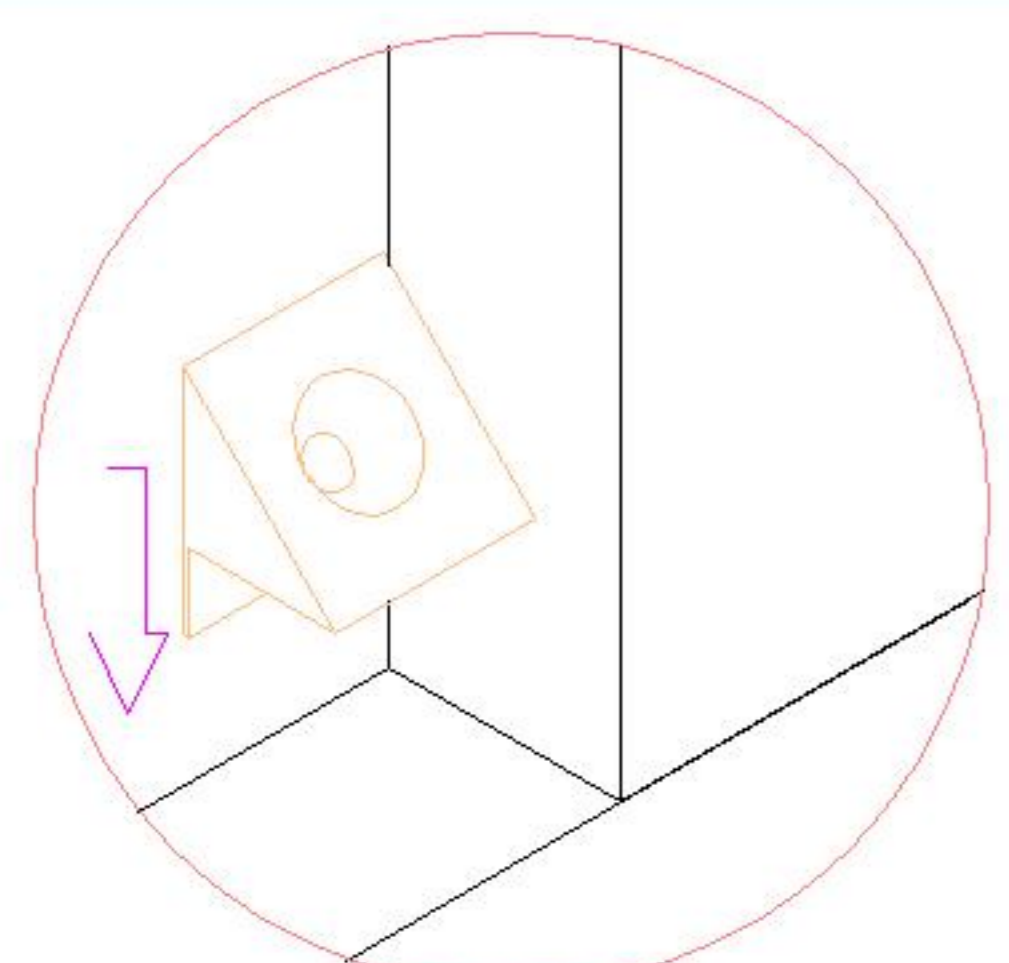

背板扣
Back Plate Buckle

(I)*14

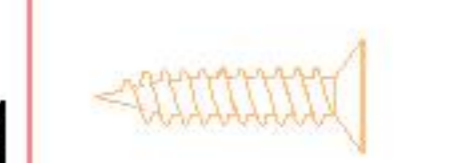

(J)*14

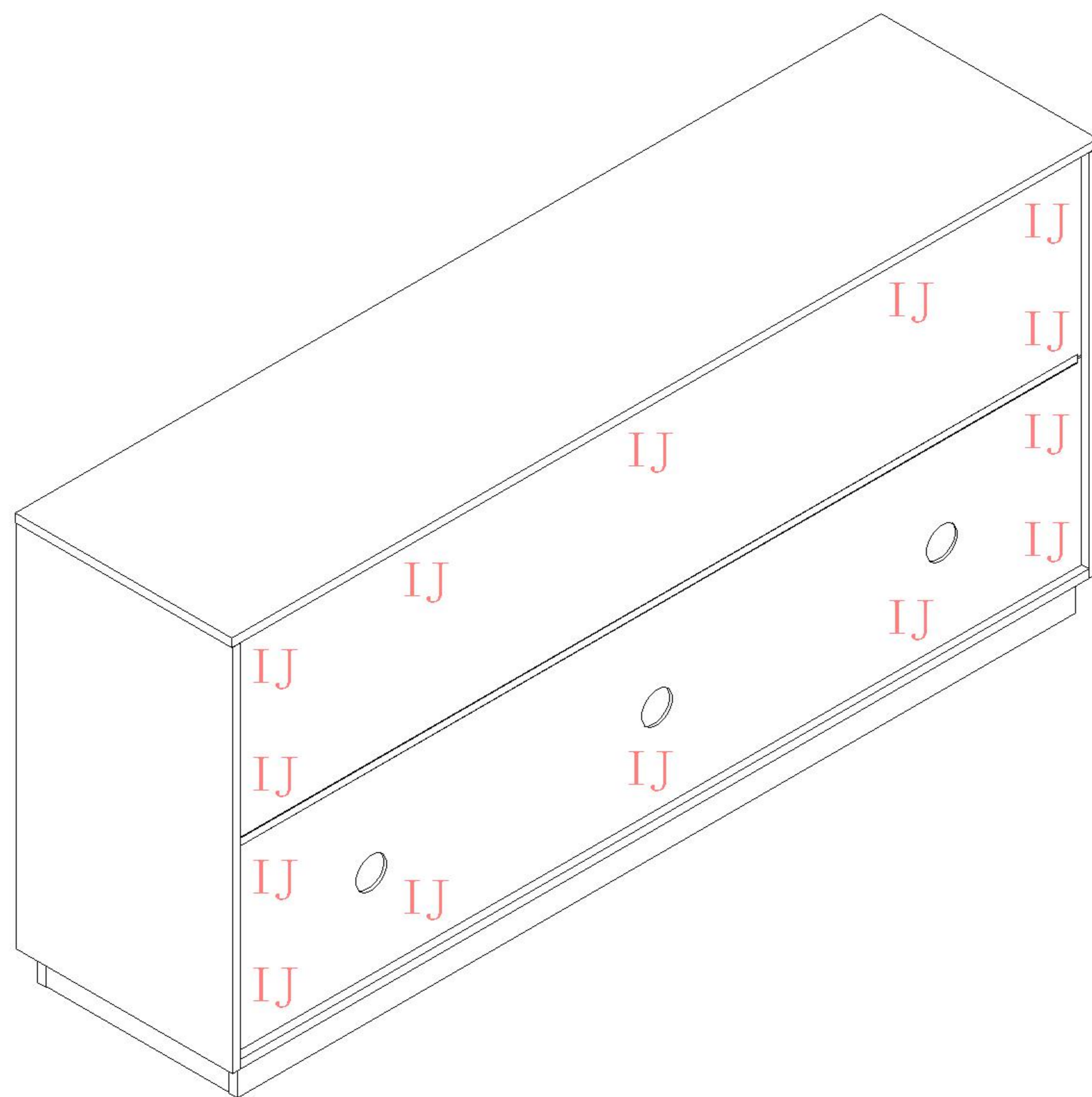

13

(M)*1

14

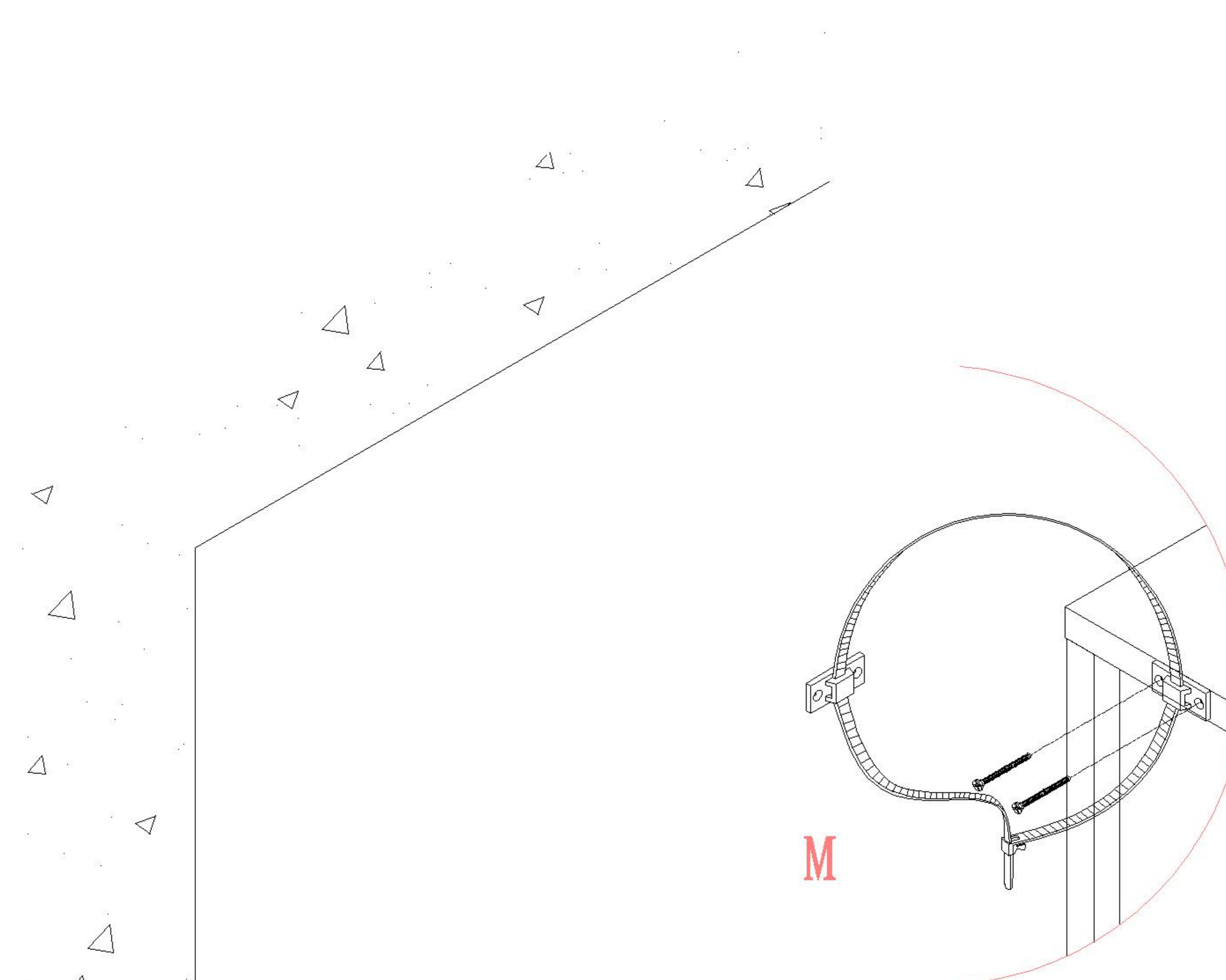

15

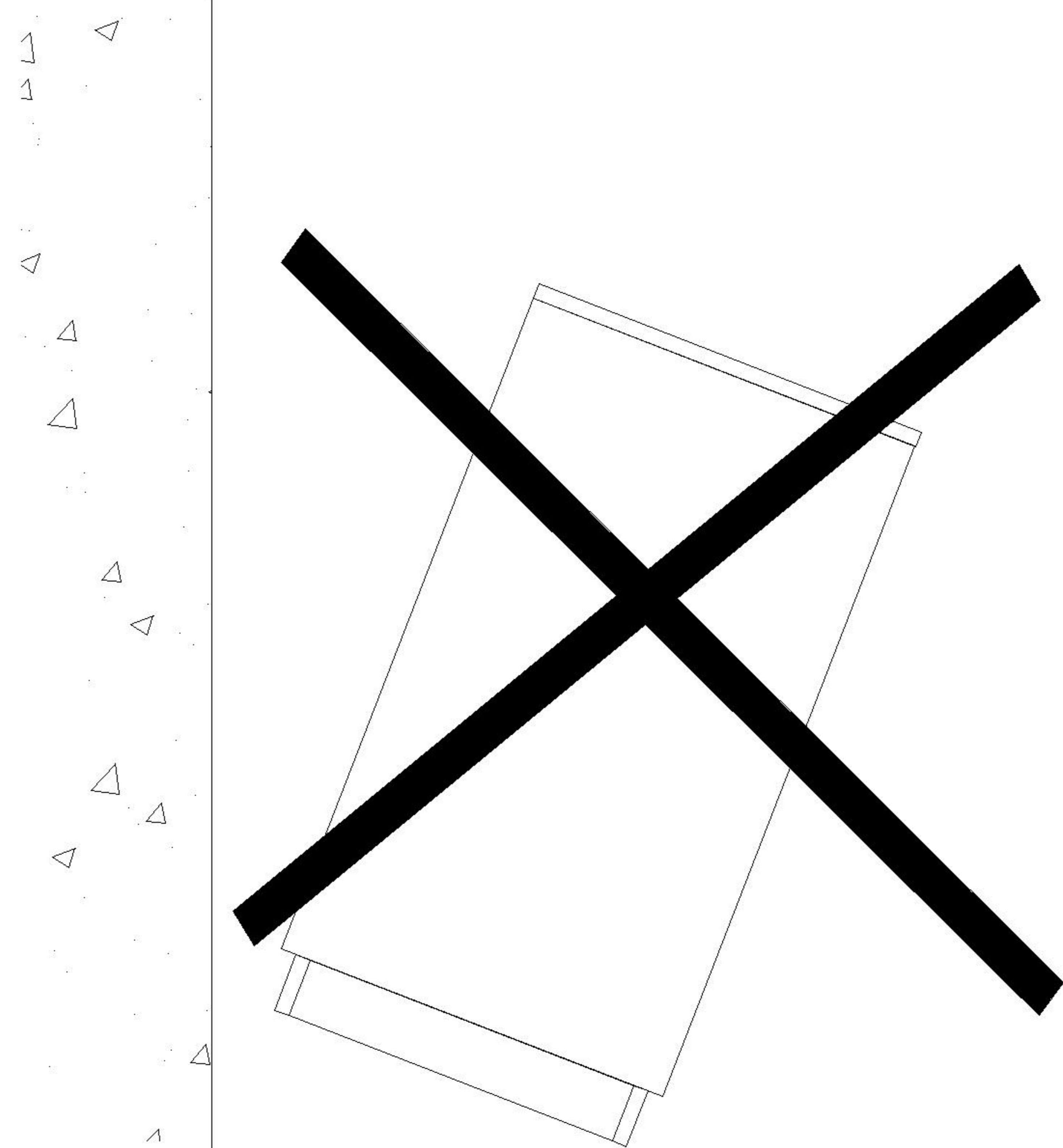

实体墙
Solid wall

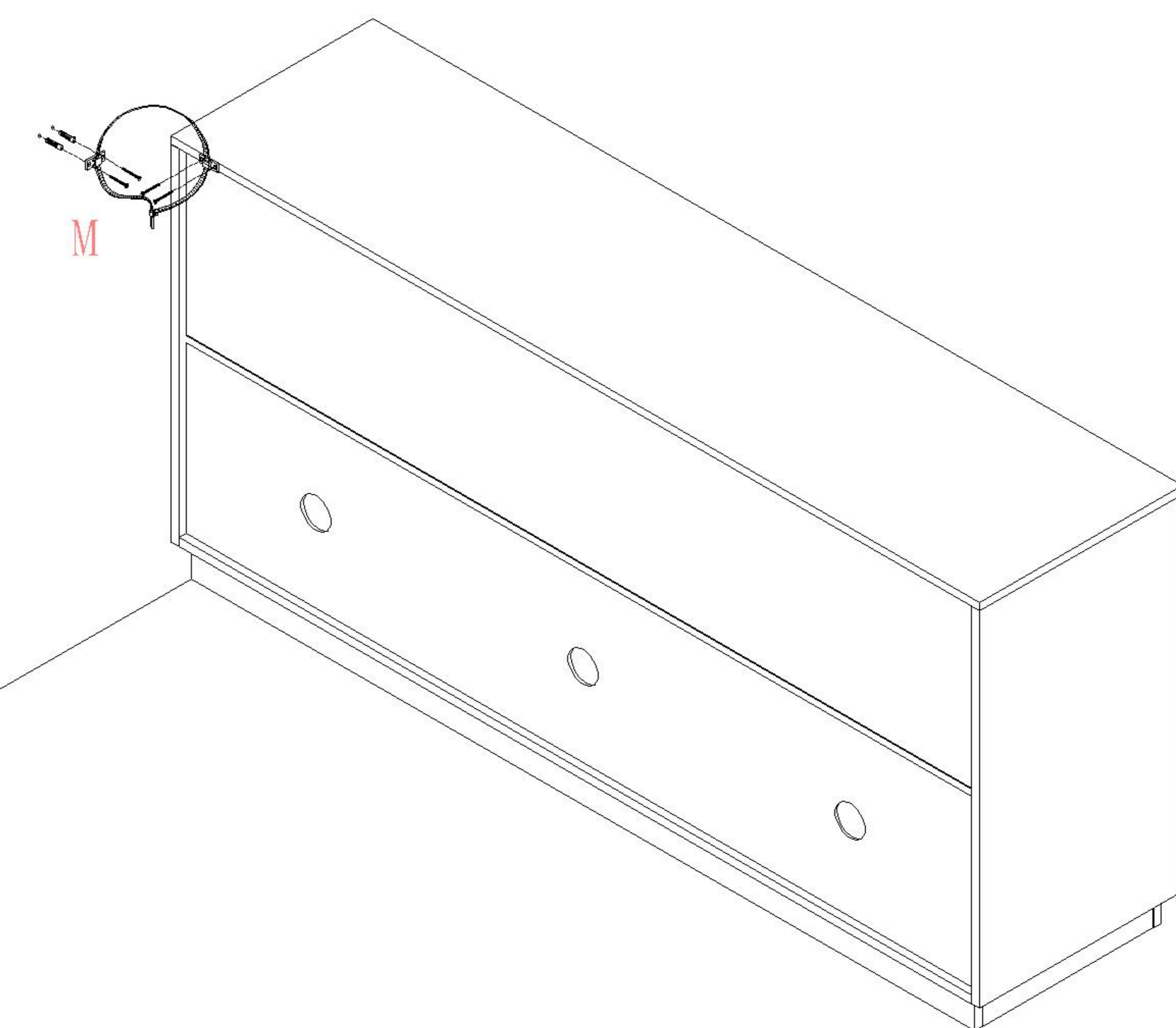

LINSY 林氏家居

五金表/Hardware list

部件表/Parts List

安装示意图/Assembly Instruction

产品名称 Model NO.	YZ1E-A 六斗柜
产品规格 Specification	1195*398*754mm
安装工具 Tool	安装人数 Installer

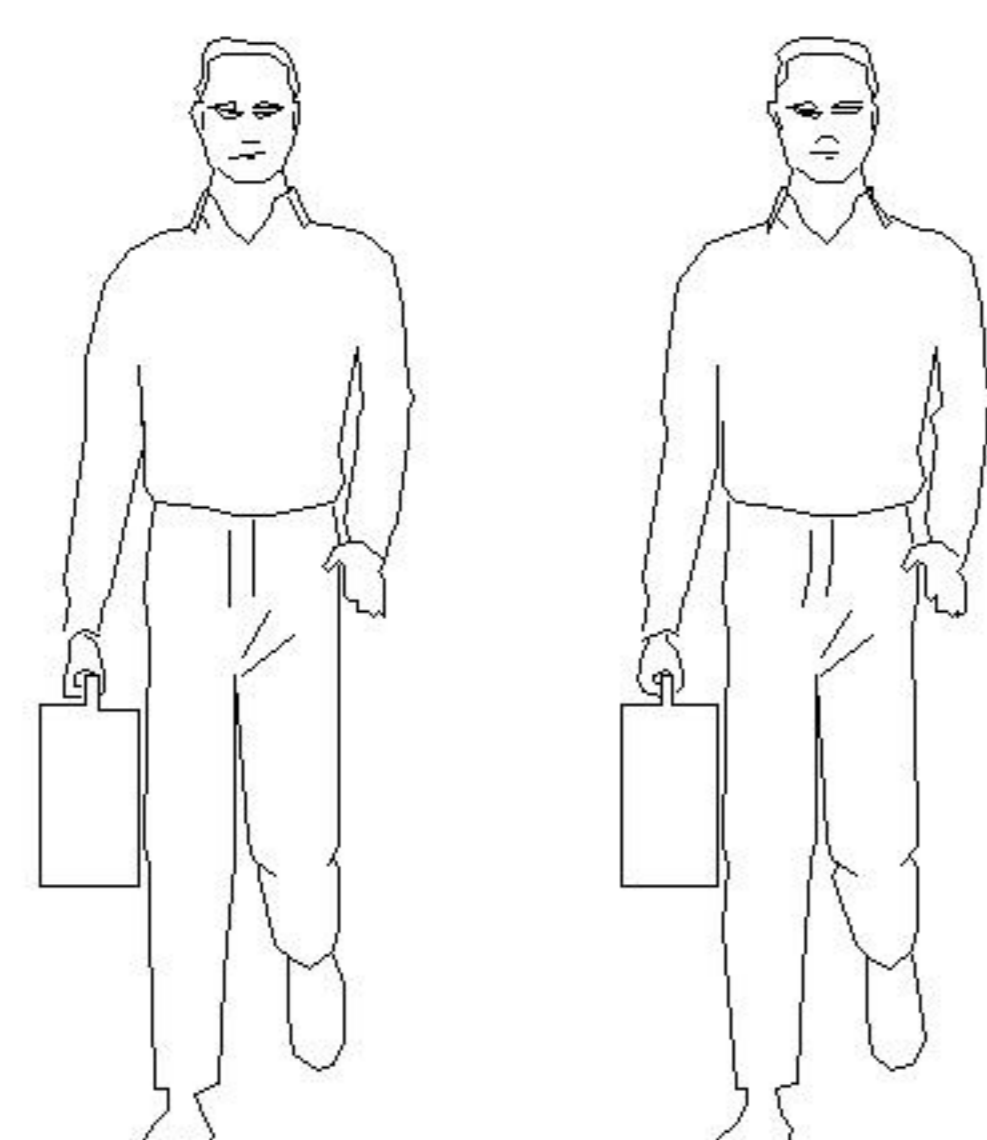
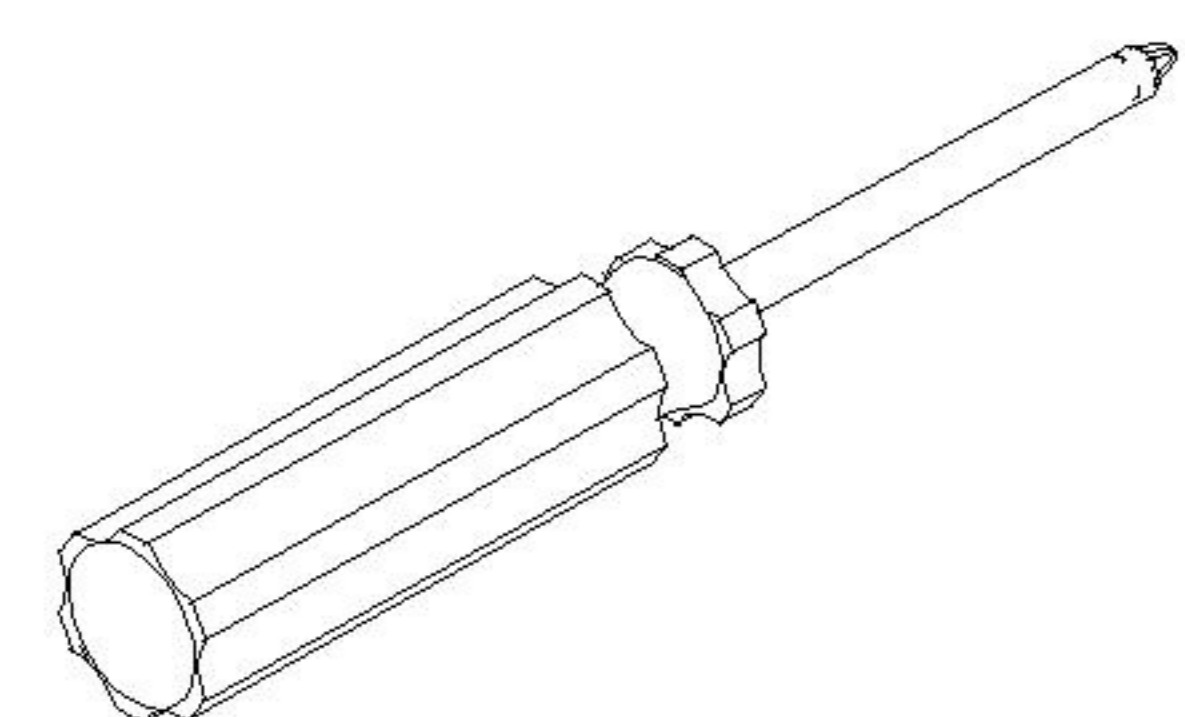

注：为保证设计效果，部分尺寸为定制尺寸，不影响使用。

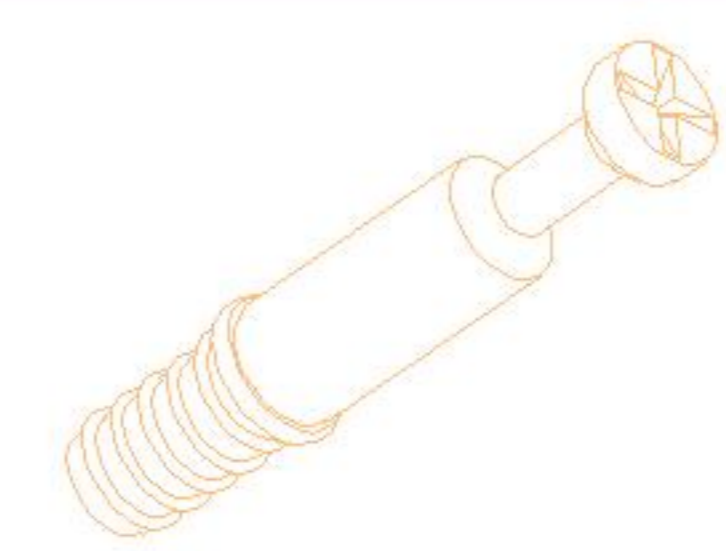
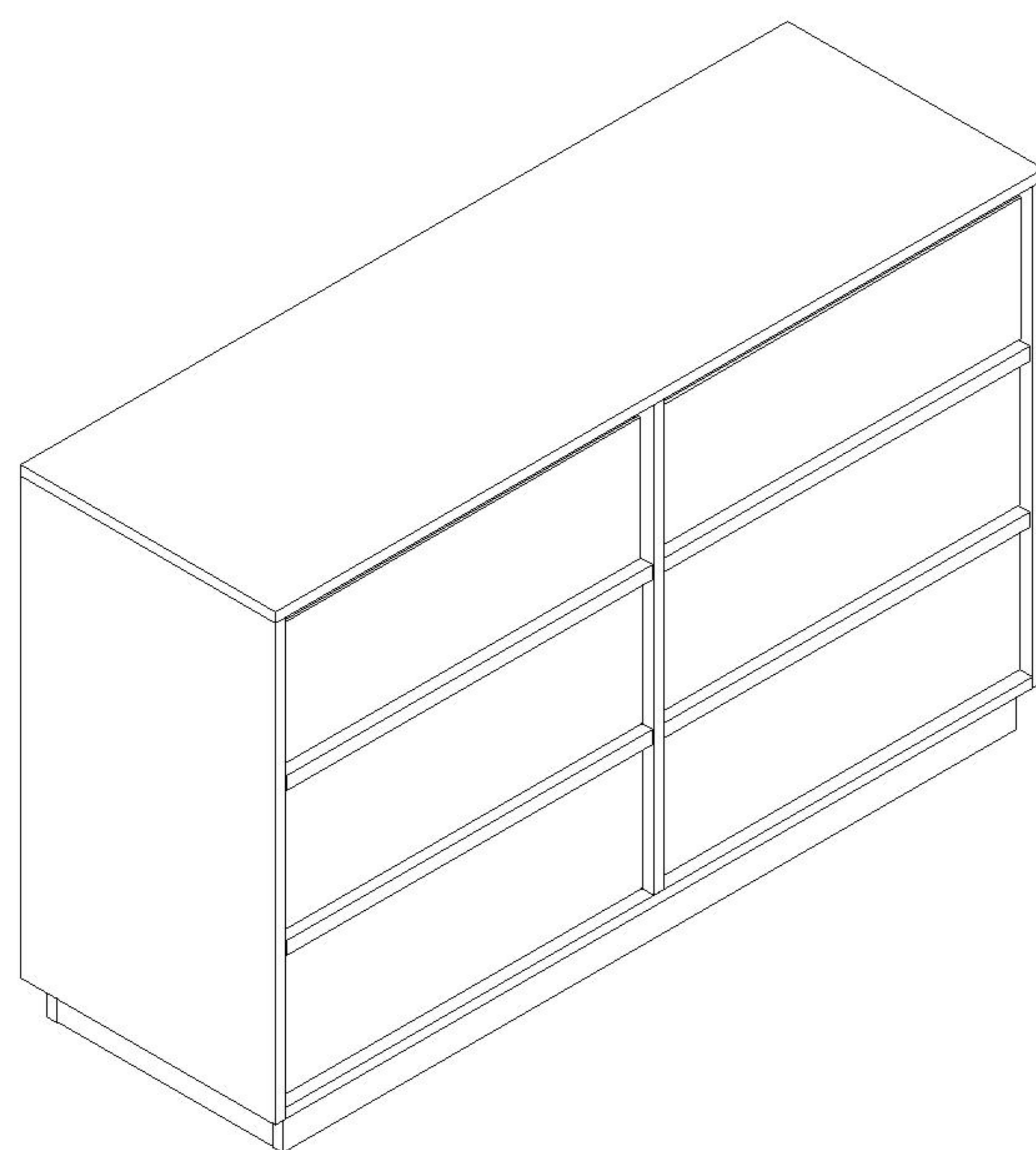

(A)*111
二合一螺杆
2-in-1-screw



(B)*117
大三合一锁饼
3-in-1 large lock

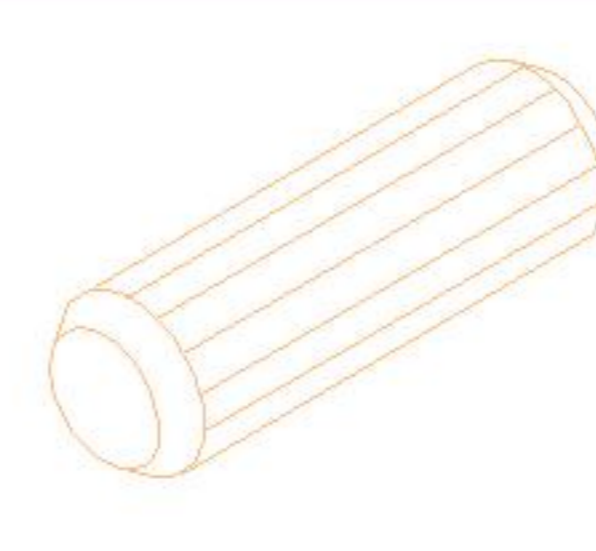

(C)*13
木榫Ø8x30mm
Wood tenon

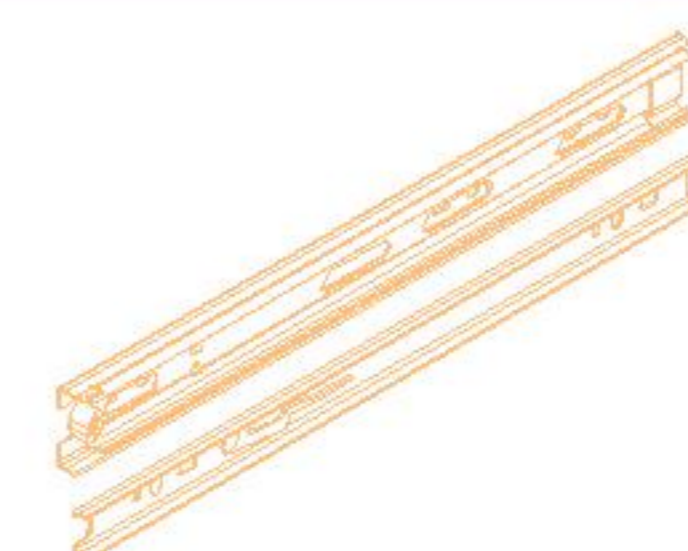

(D)*6
三节滚珠导轨10"
Three-section rail



(E)*3
双头三合一螺杆64
double-head
three-in-one screw

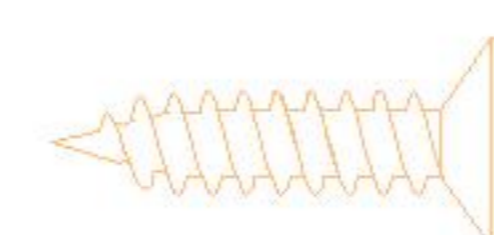

(F)*84
白攻螺丝M3.5*12mm
Tapping screw

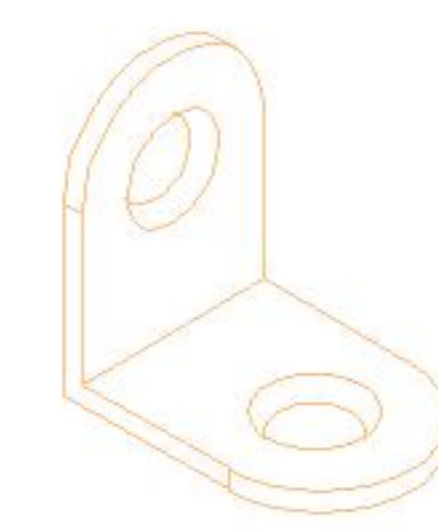

(G)*4
角码-(30*30*16mm)L型
Corner code

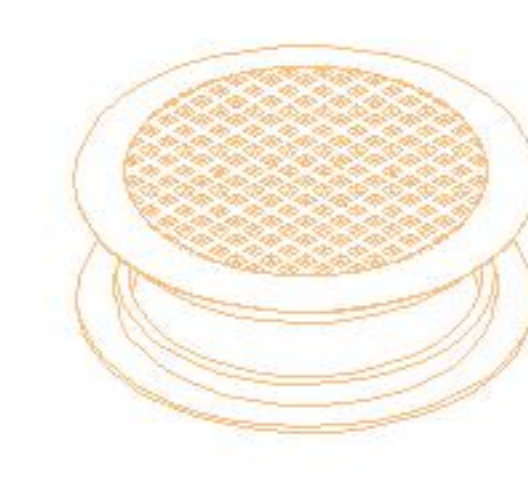

(H)*2
透气孔盖-白色
Breathable cover

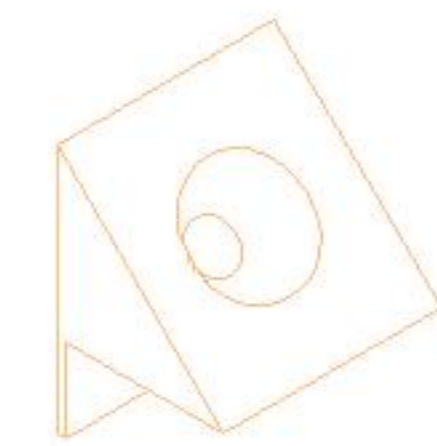

(I)*13
背板扣
White buckle

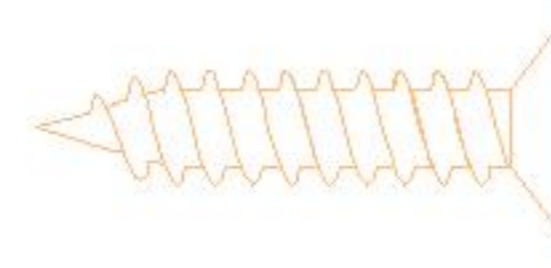

(J)*13
白攻螺丝M3.5*16mm
Tapping screw



(K)*1
夹板条 L=1162mm
Splint strip



(L)*9
灰色毛毡脚垫(Φ16*3mm)
Foot pad

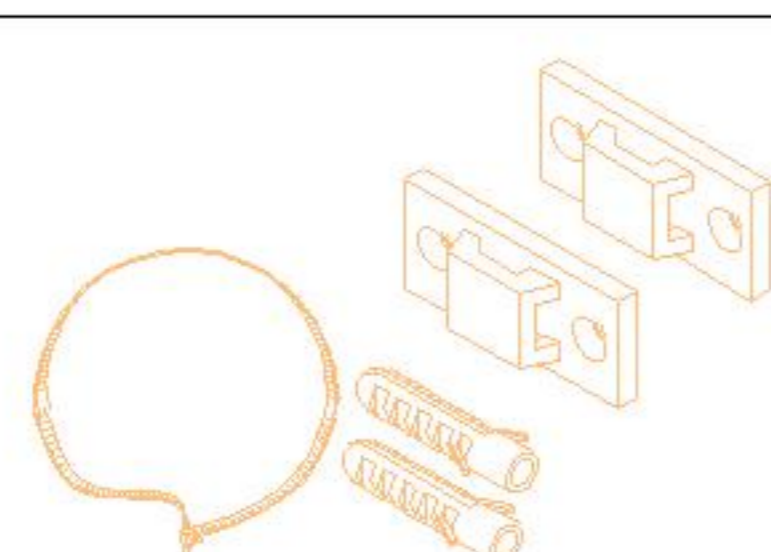

(M)*1
家具防倒器-白色
Anti-fall device

编号NO.	名称Name	规格(mm) Specification	数量QTY	材质Material
①	面板Top panel	1195*398*15	1	刨花板 Particle board
②	底板Bottom board	1163*397*15	1	刨花板 Particle board
③	左侧板Side board(L)	678*397*15	1	刨花板 Particle board
④	右侧板Side board(R)	678*397*15	1	刨花板 Particle board
⑤	中侧板Middle side board	663*375*15	1	刨花板 Particle board
⑥	上拉条Top brace	574*58*15	2	刨花板 Particle board
⑦	下拉条Bottom brace	574*58*15	2	刨花板 Particle board
⑧	前后脚条Front and rear foot strips	1143*58*15	2	刨花板 Particle board
⑨	侧脚条Side foot strip	337*58*15	3	刨花板 Particle board
⑩	拉手Handle	570*30*20	4	橡胶木Rubber wood
⑪	上抽屉面板Upper drawer's panel	570*190*15	2	刨花板 Particle board
⑫	上抽屉侧板Upper drawer side panel	295*110*15	4	刨花板 Particle board
⑬	上抽屉后板Upper drawer's back board	548*110*15	2	刨花板 Particle board
⑭	下抽屉面板Bottom drawer's panel	570*206*15	4	刨花板 Particle board
⑮	下抽屉侧板Lower drawer side panel	295*142*15	8	刨花板 Particle board
⑯	下抽屉后板Down drawer's back board	548*142*15	4	刨花板 Particle board
⑰	抽屉底板Drawer's Bottom board	528*305*5	6	纤维板Fiberboard
⑱	背板1Back board 1	1173*335*5	1	纤维板Fiberboard
⑲	背板2Back board 2	1173*335*5	1	纤维板Fiberboard

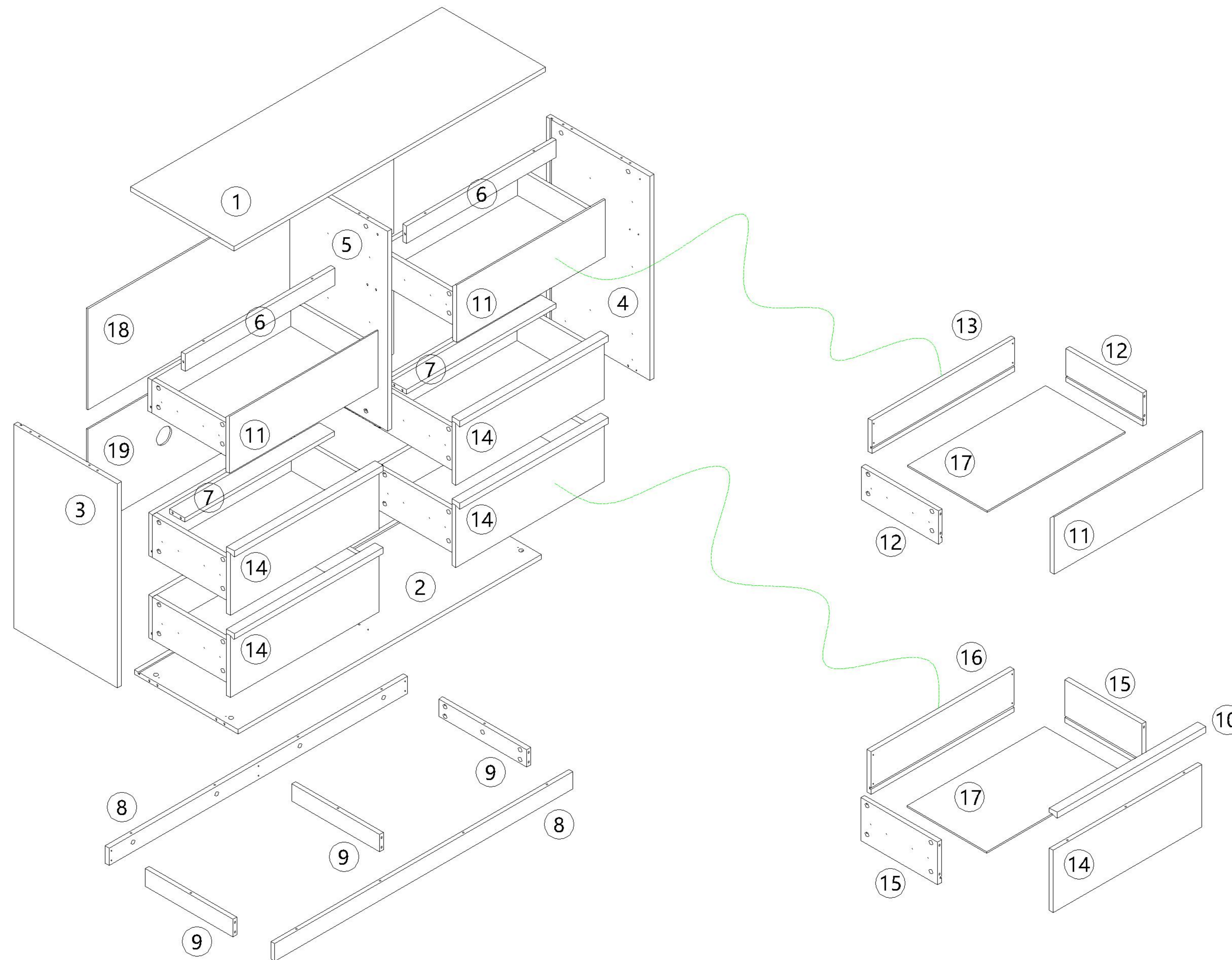

编号NO.	名称Name
①	面板Top panel
②	底板Bottom board
③	左侧板Side board(L)
④	右侧板Side board(R)
⑤	中侧板Middle side board
⑥	上拉条Top brace
⑦	下拉条Bottom brace
⑧	前后脚条Front and rear foot strips
⑨	侧脚条Side foot strip
⑩	拉手Handle
⑪	上抽屉面板Upper drawer's panel
⑫	上抽屉侧板Upper drawer side panel
⑬	上抽屉后板Upper drawer's back board
⑭	下抽屉面板Bottom drawer's panel
⑮	下抽屉侧板Lower drawer side panel
⑯	下抽屉后板Down drawer's back board
⑰	抽屉底板Drawer's Bottom board
⑱	背板1Back board 1
⑲	背板2Back board 2

YZ1E-A 六斗柜

安装方法/
Installation method

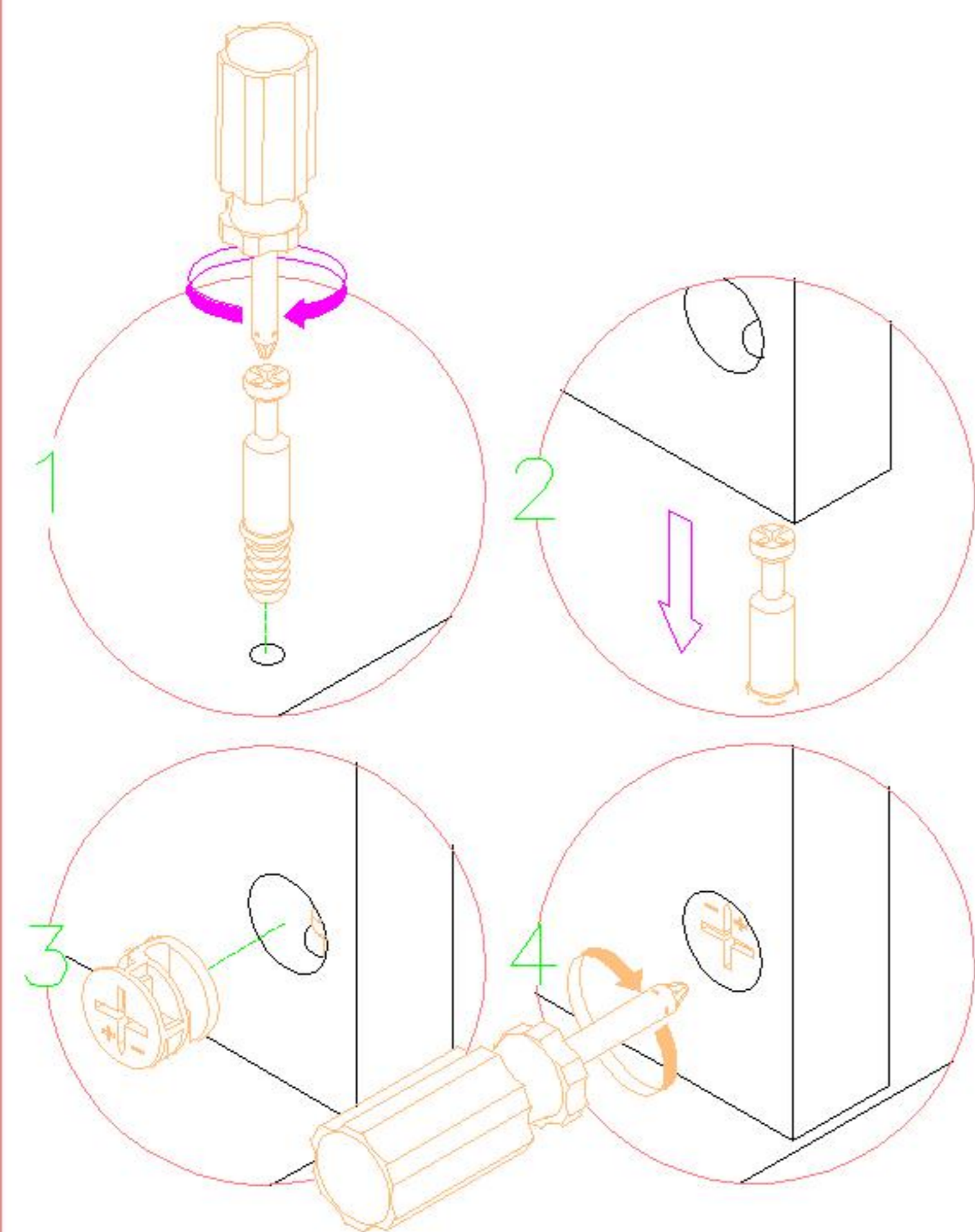

二合一 two-in-one

阀门开关(下压为开)
Valve switch (press down to open)

前 Forward 后 Back



主轨 Main track

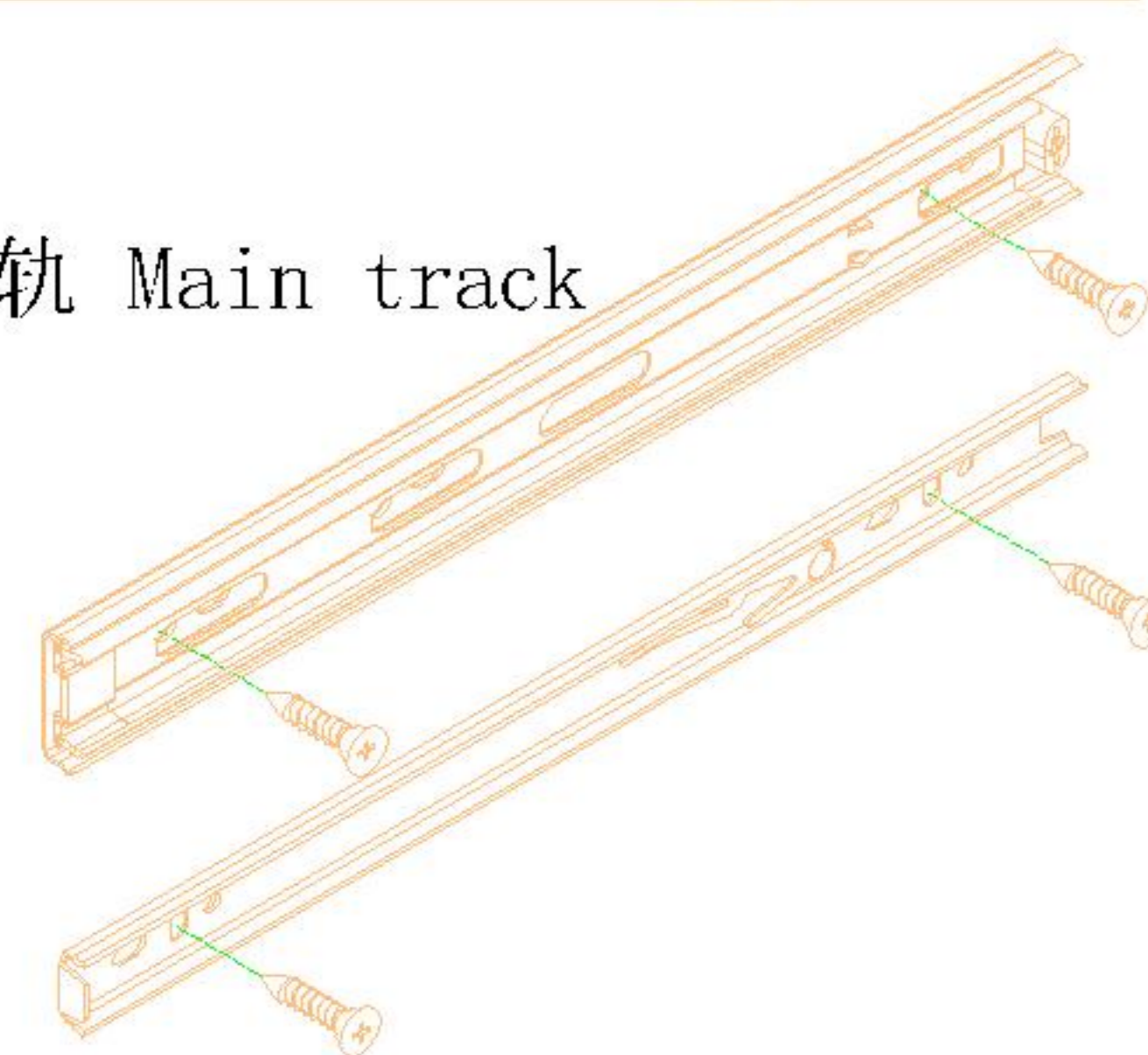

三节滚珠导轨-10"
Three-section rail

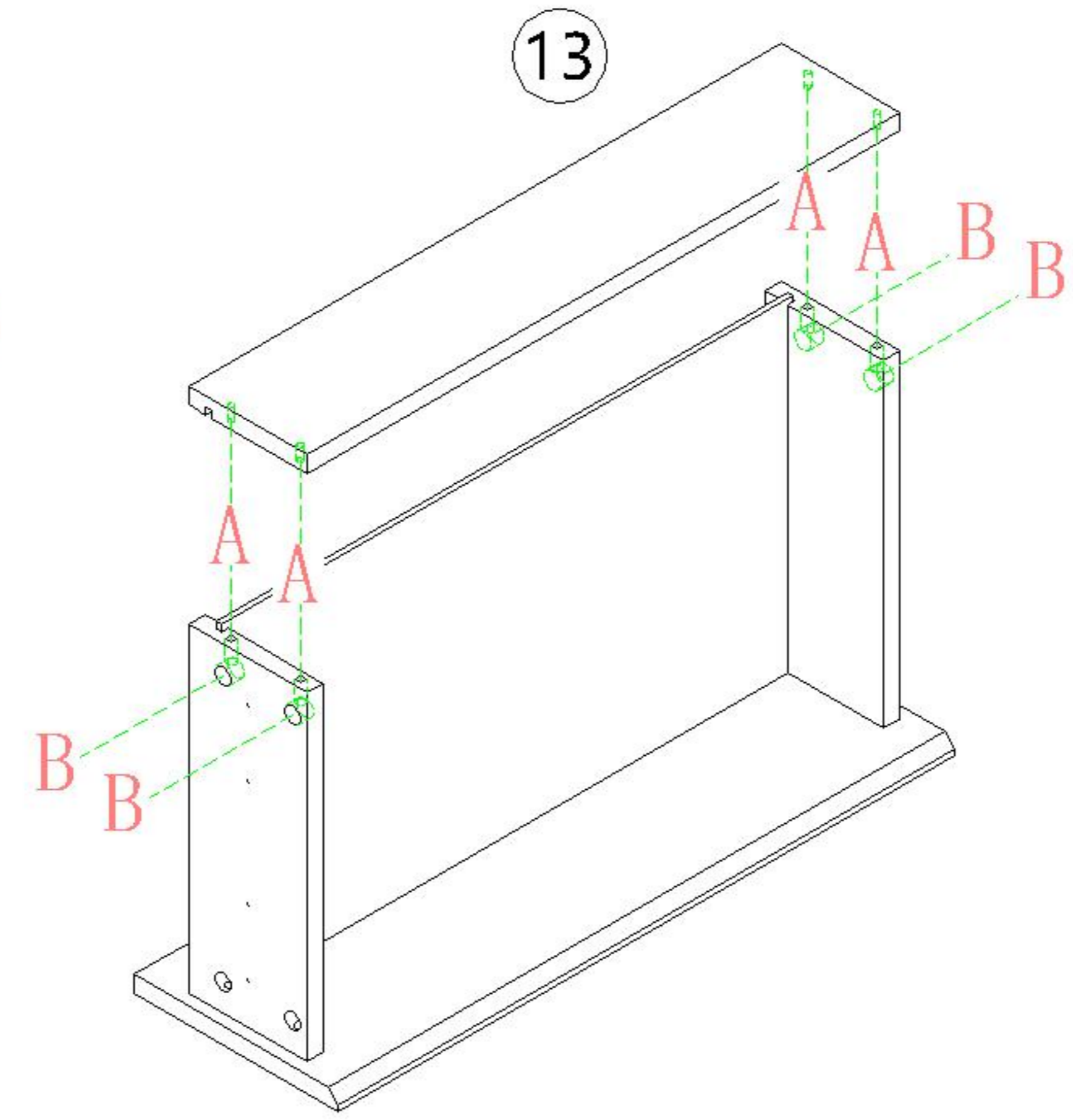
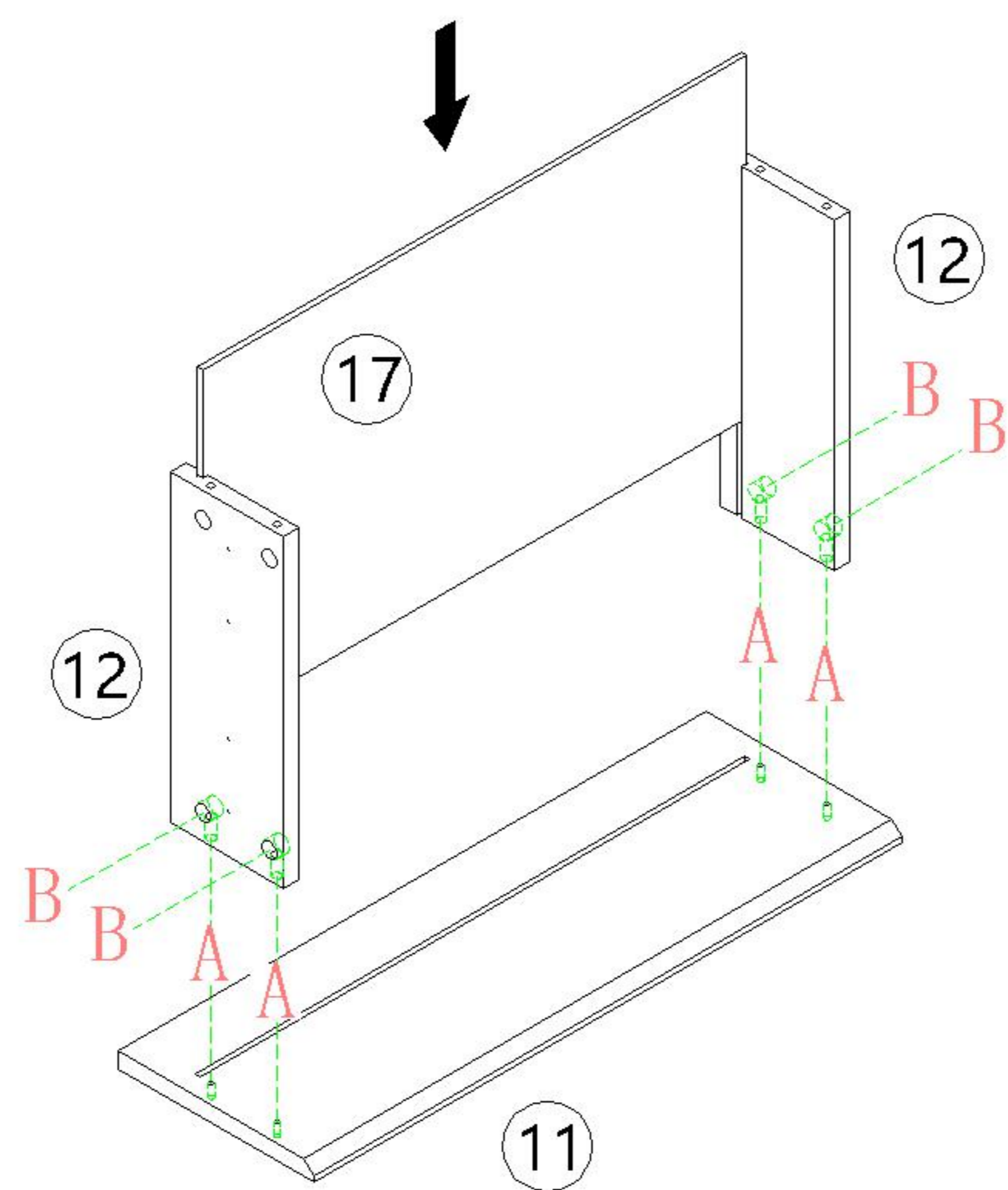
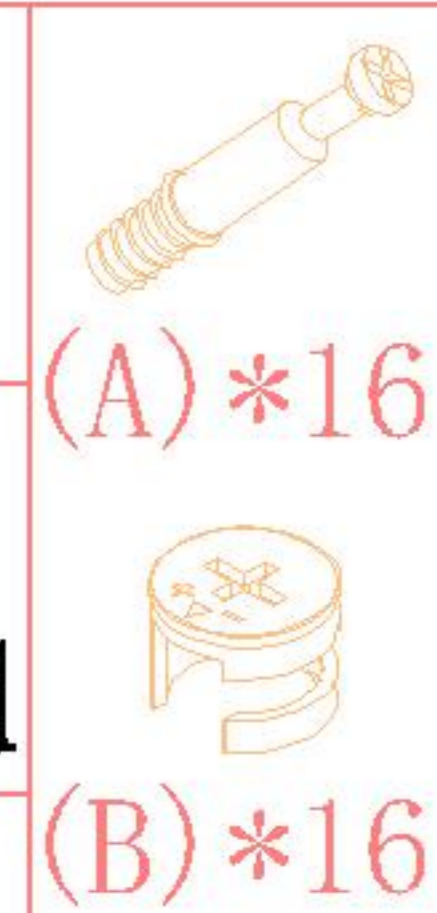

× 2

1

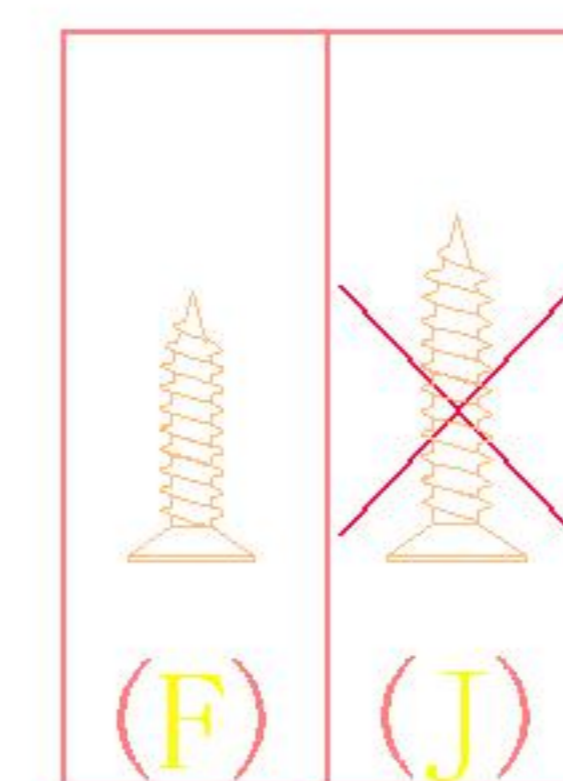
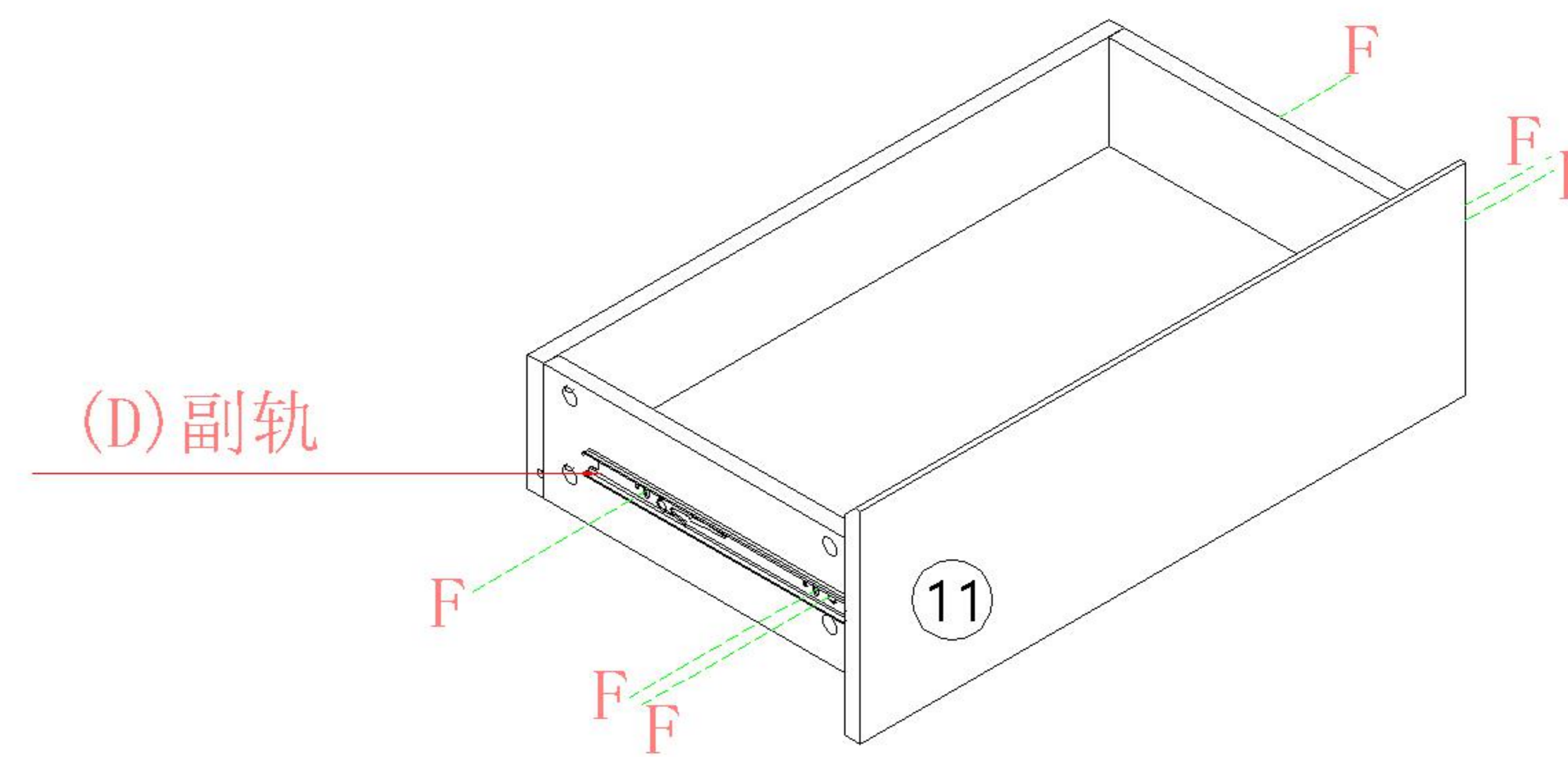
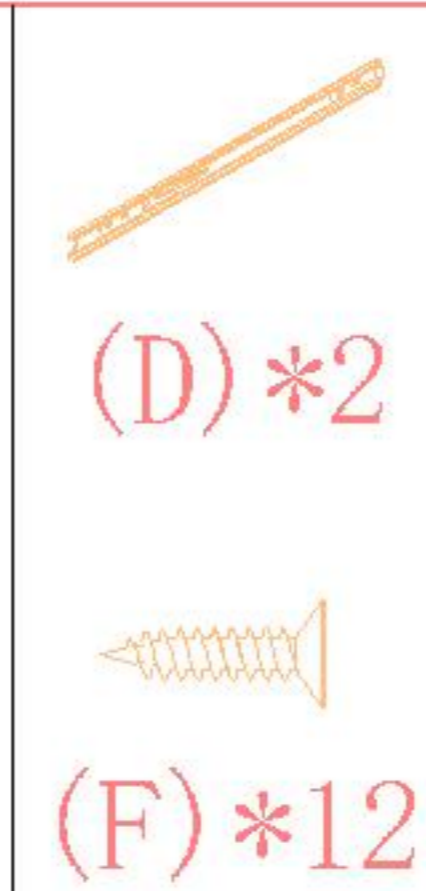

× 2

2

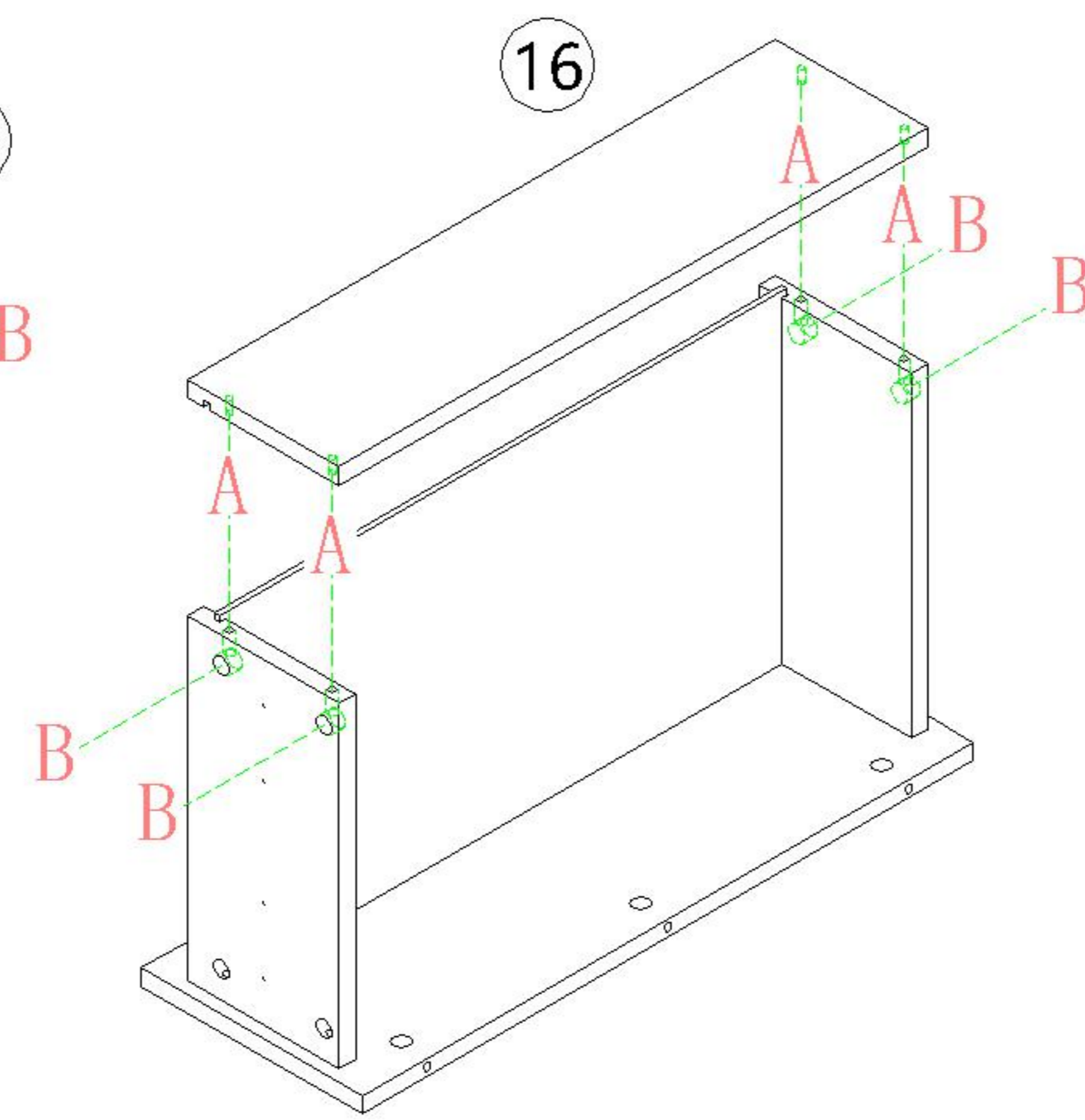
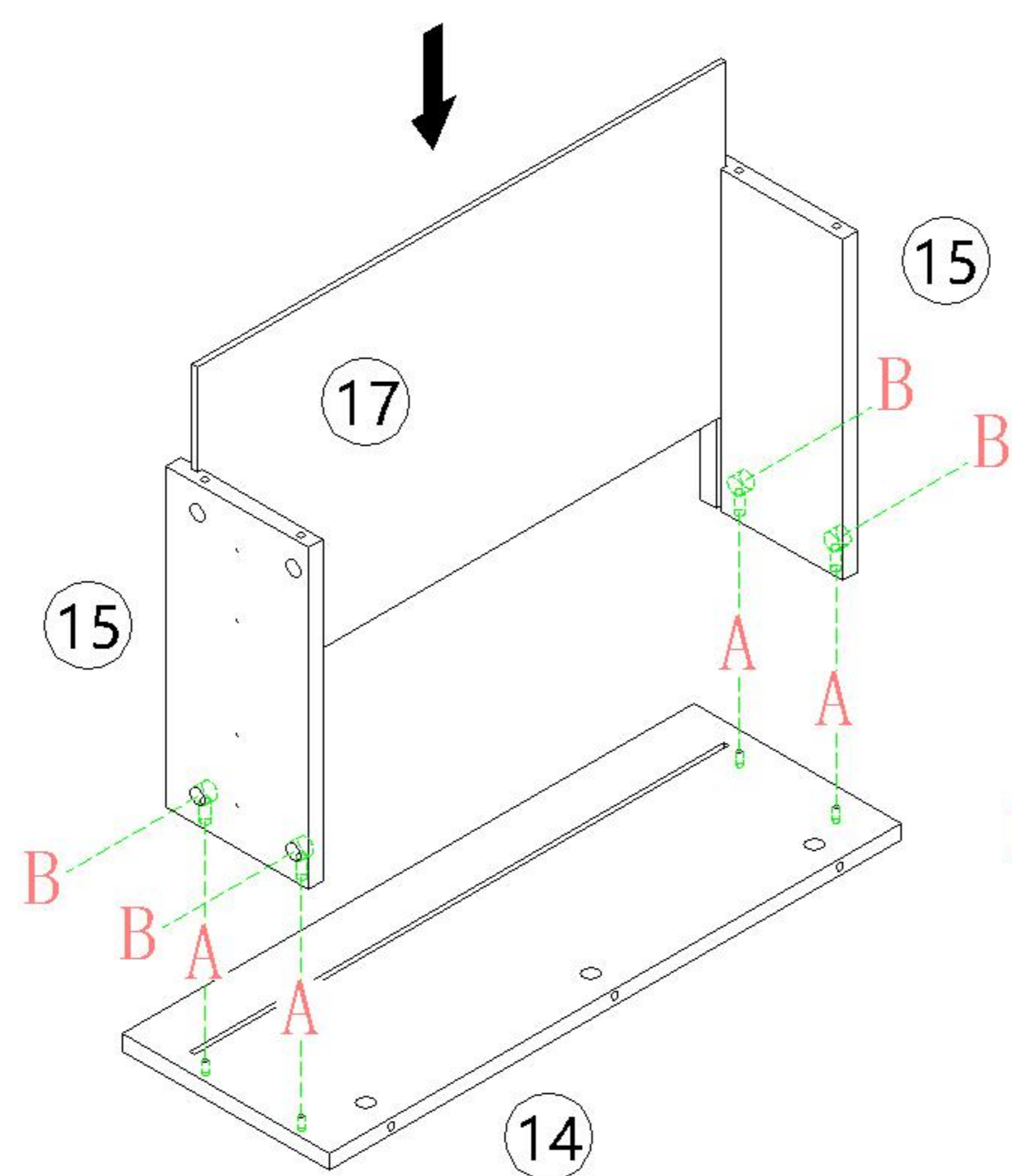

× 4

3

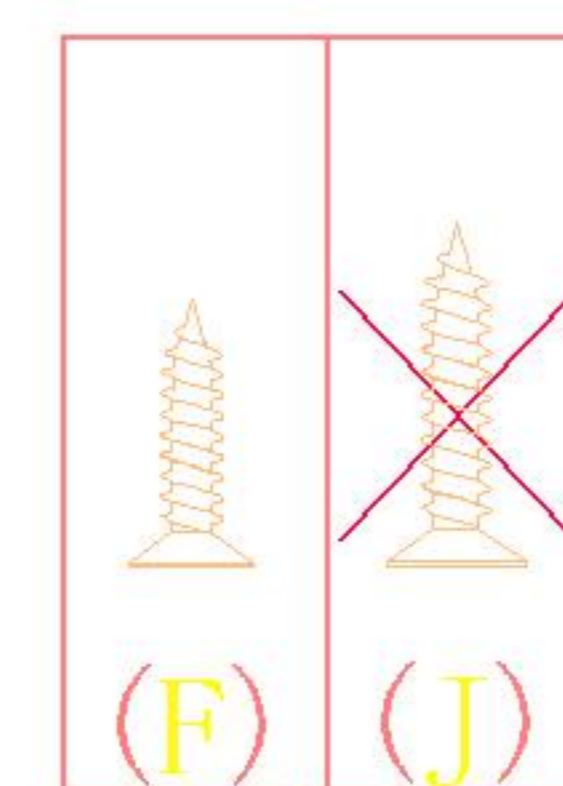
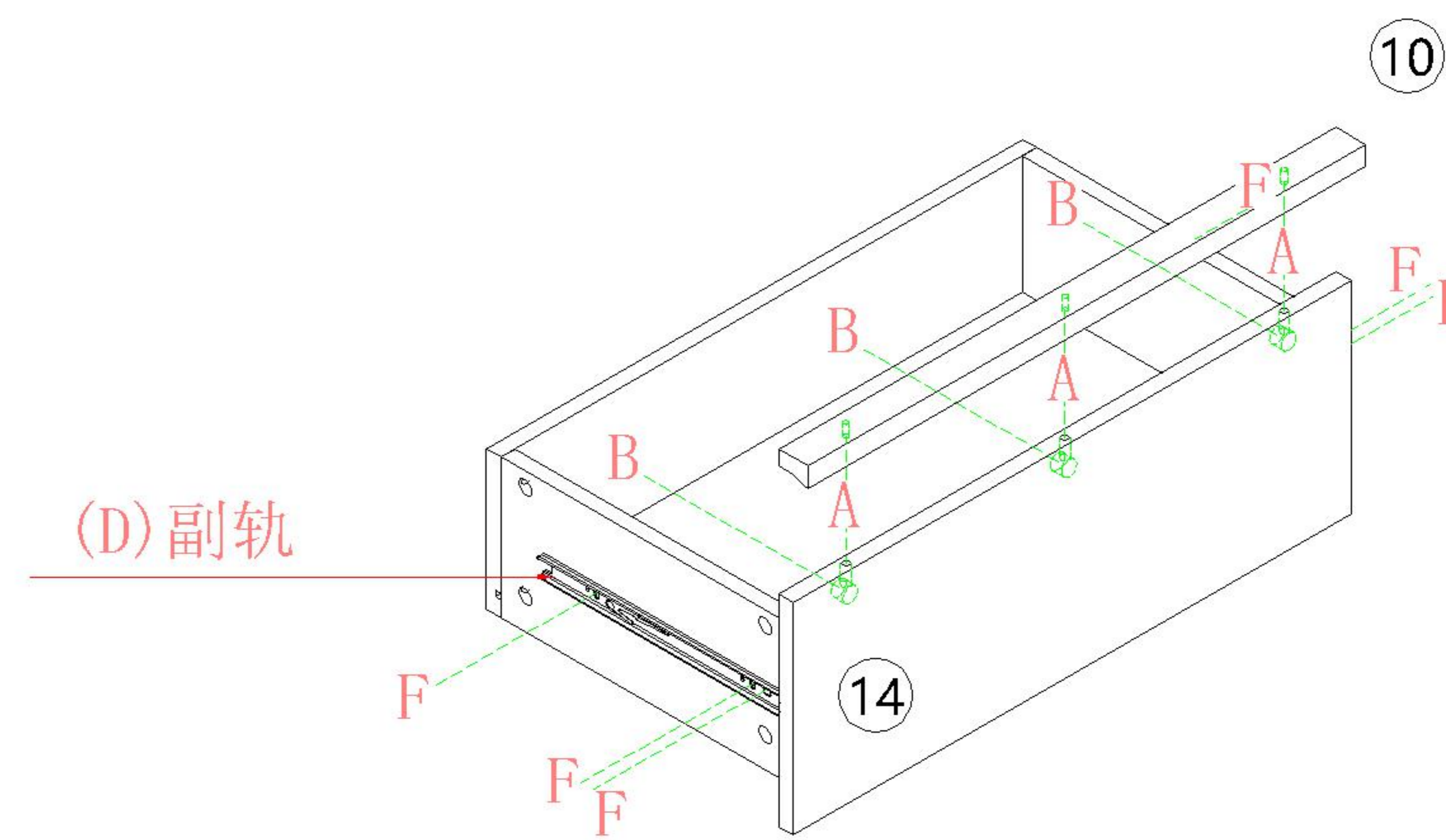
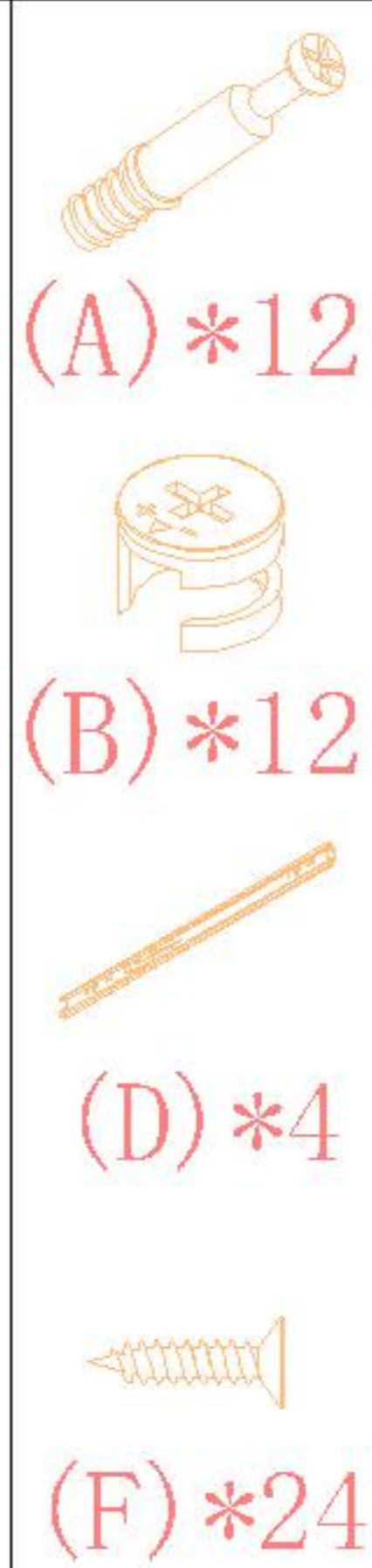

× 4

4

YZ1E-A 六斗柜

安装方法/
Installation method

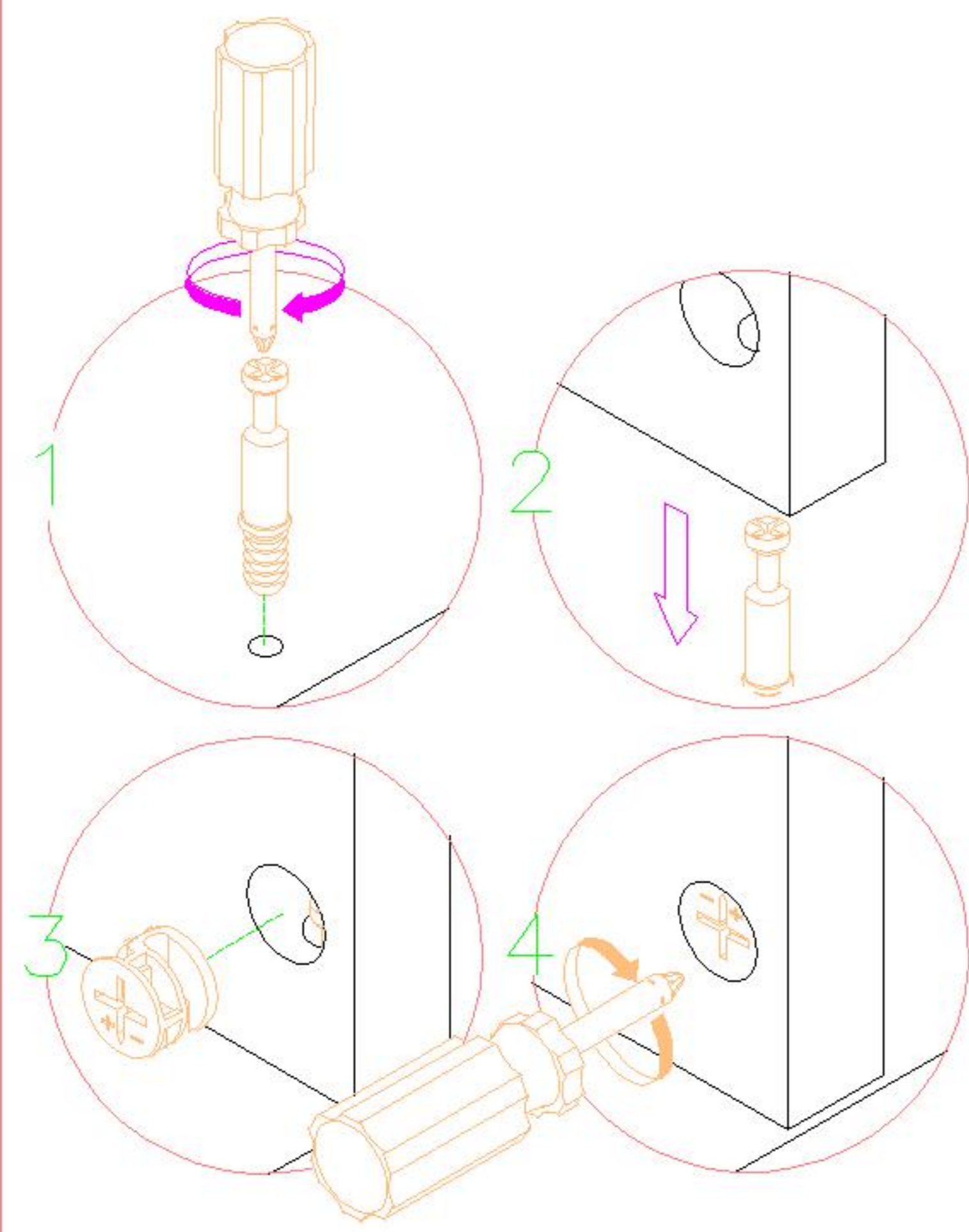

二合一 two-in-one

- (A)*2
- (B)*2
- (C)*2

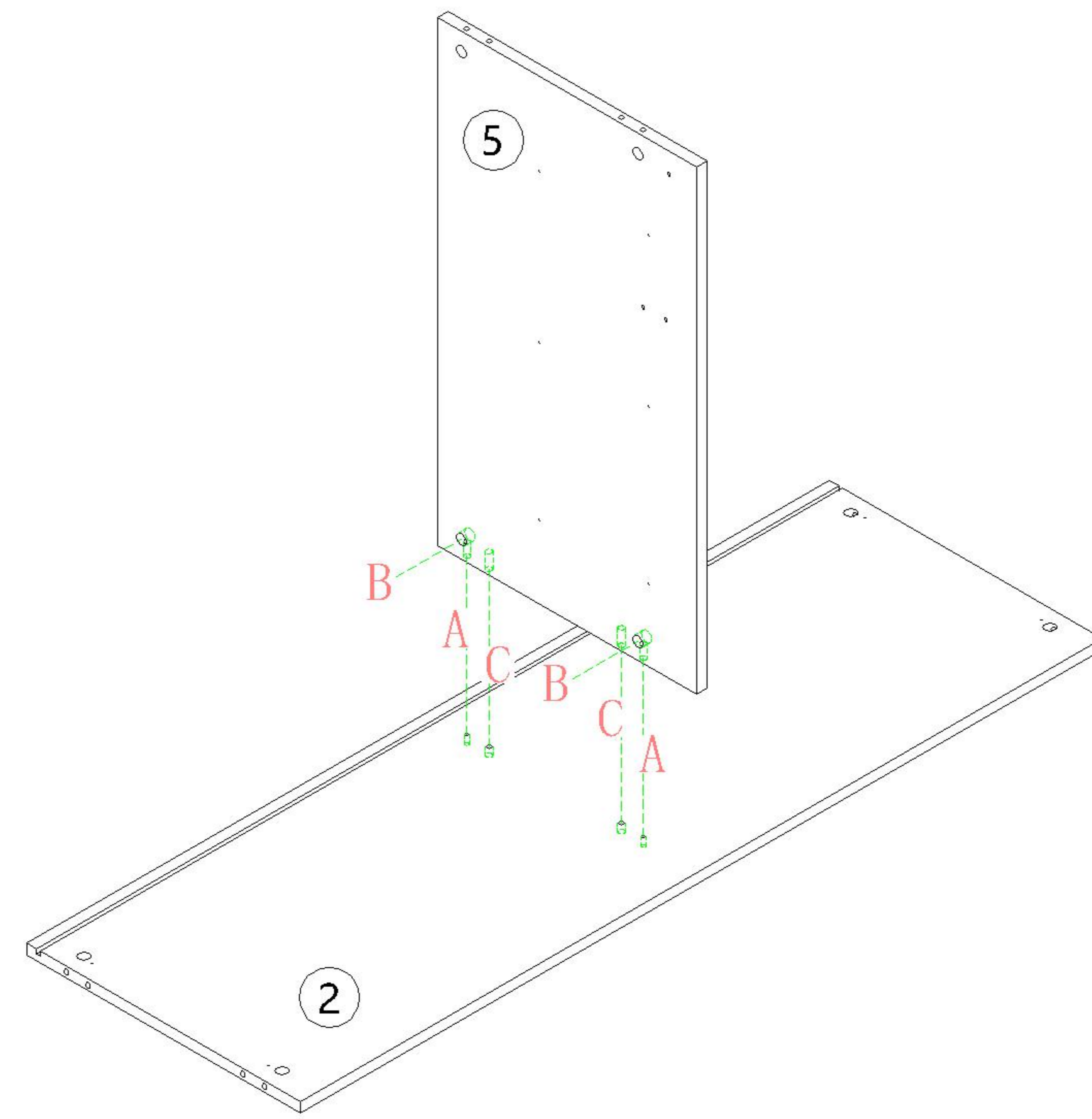

5

- (A)*10 (E)*3 (G)*4
- (B)*16 (F)*8
- (C)*4

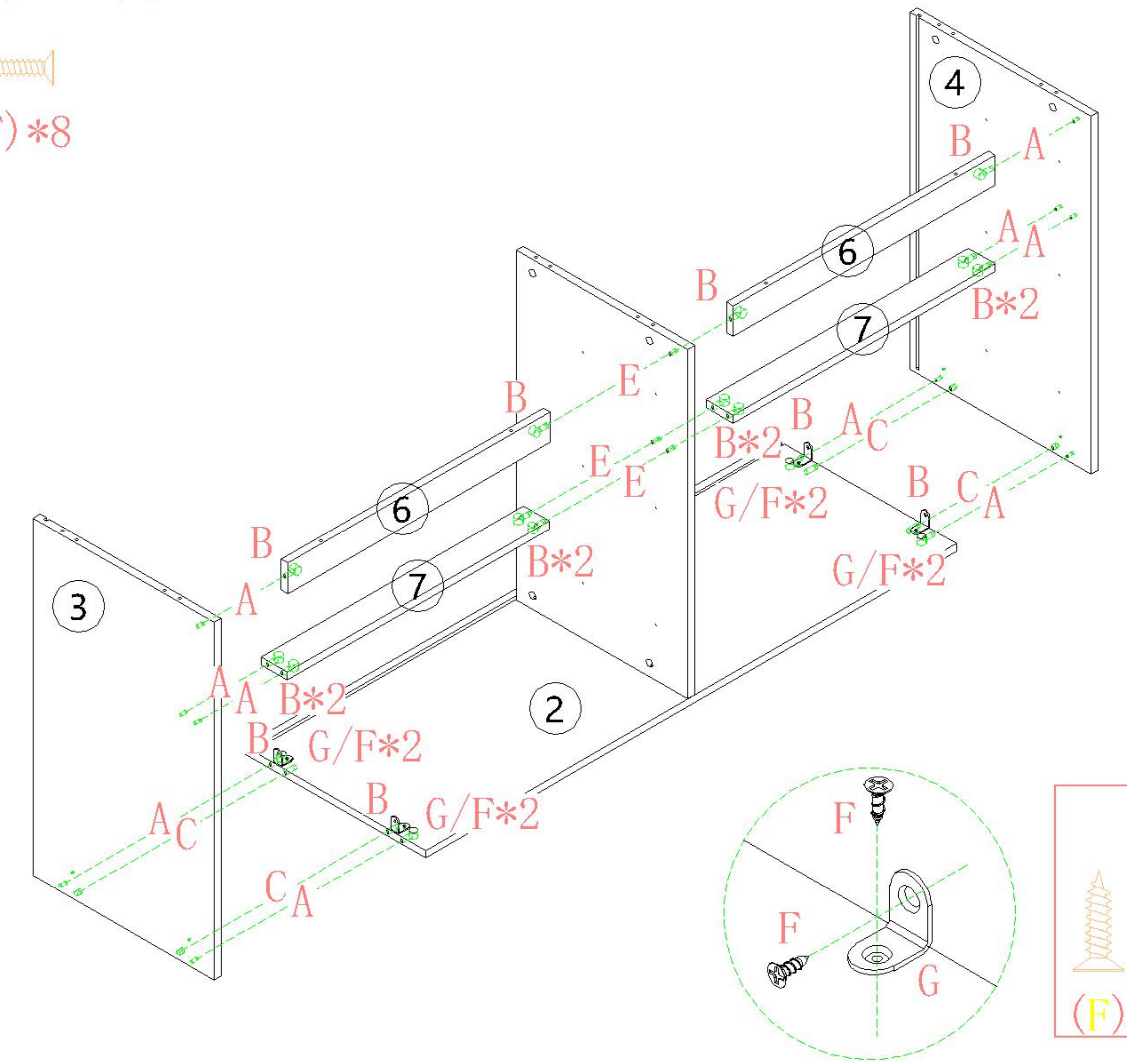

6

- (H)*2
- (K)*1

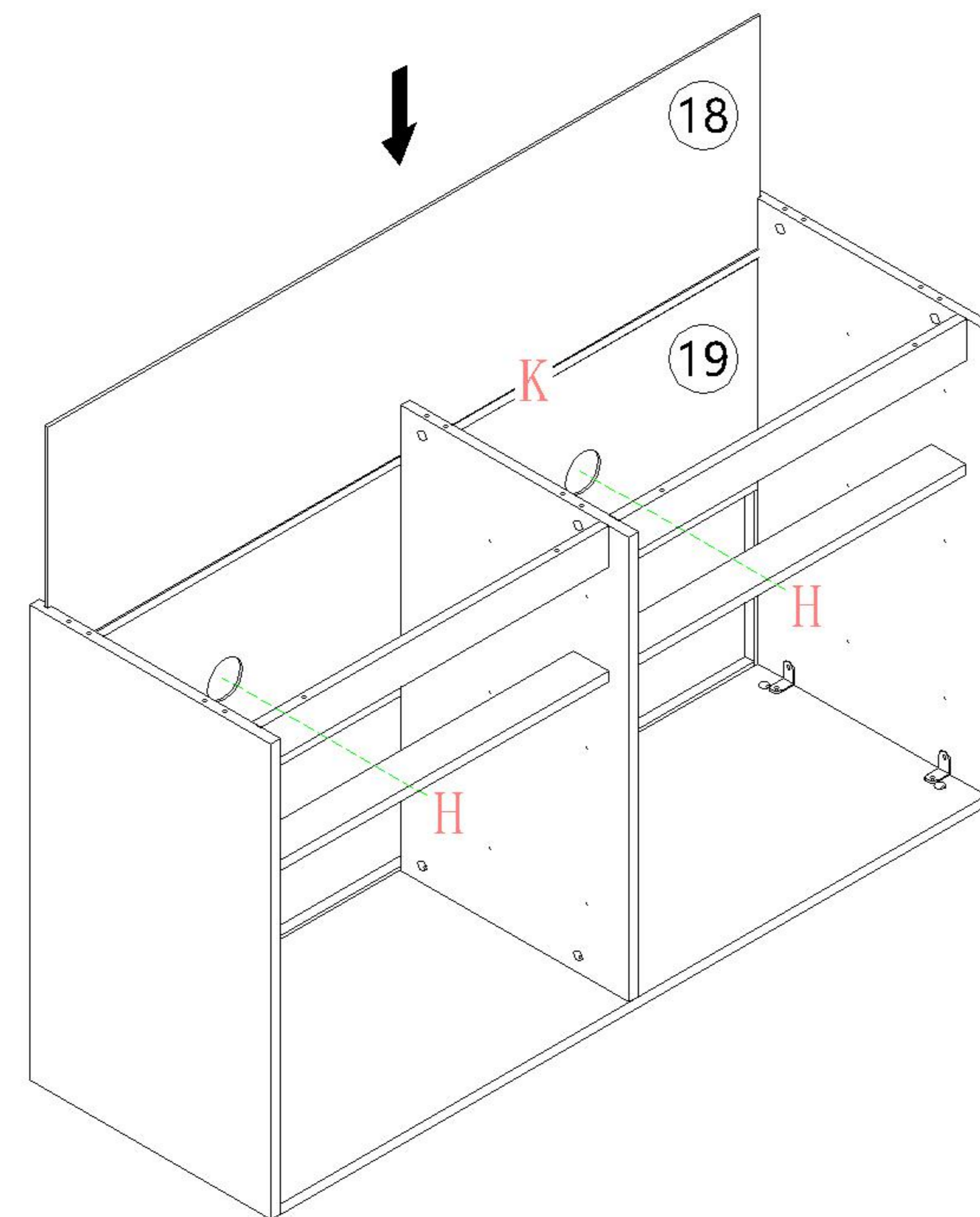

7

- (A)*10
- (B)*10
- (C)*6

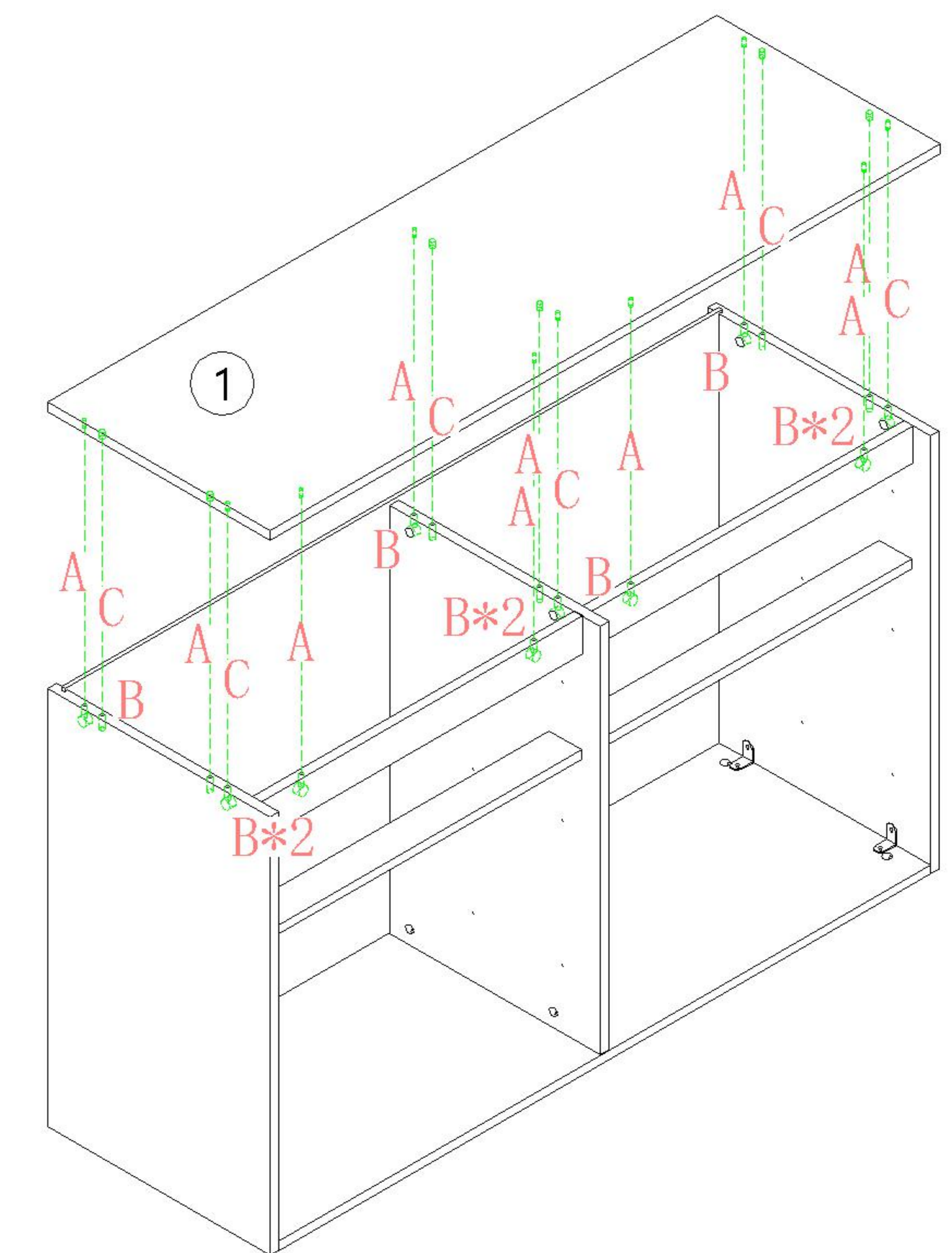

8

YZ1E-A 六斗柜

安装方法/
Installation method

1 阀门开关(下压为开)
Valve switch
(press down to open)

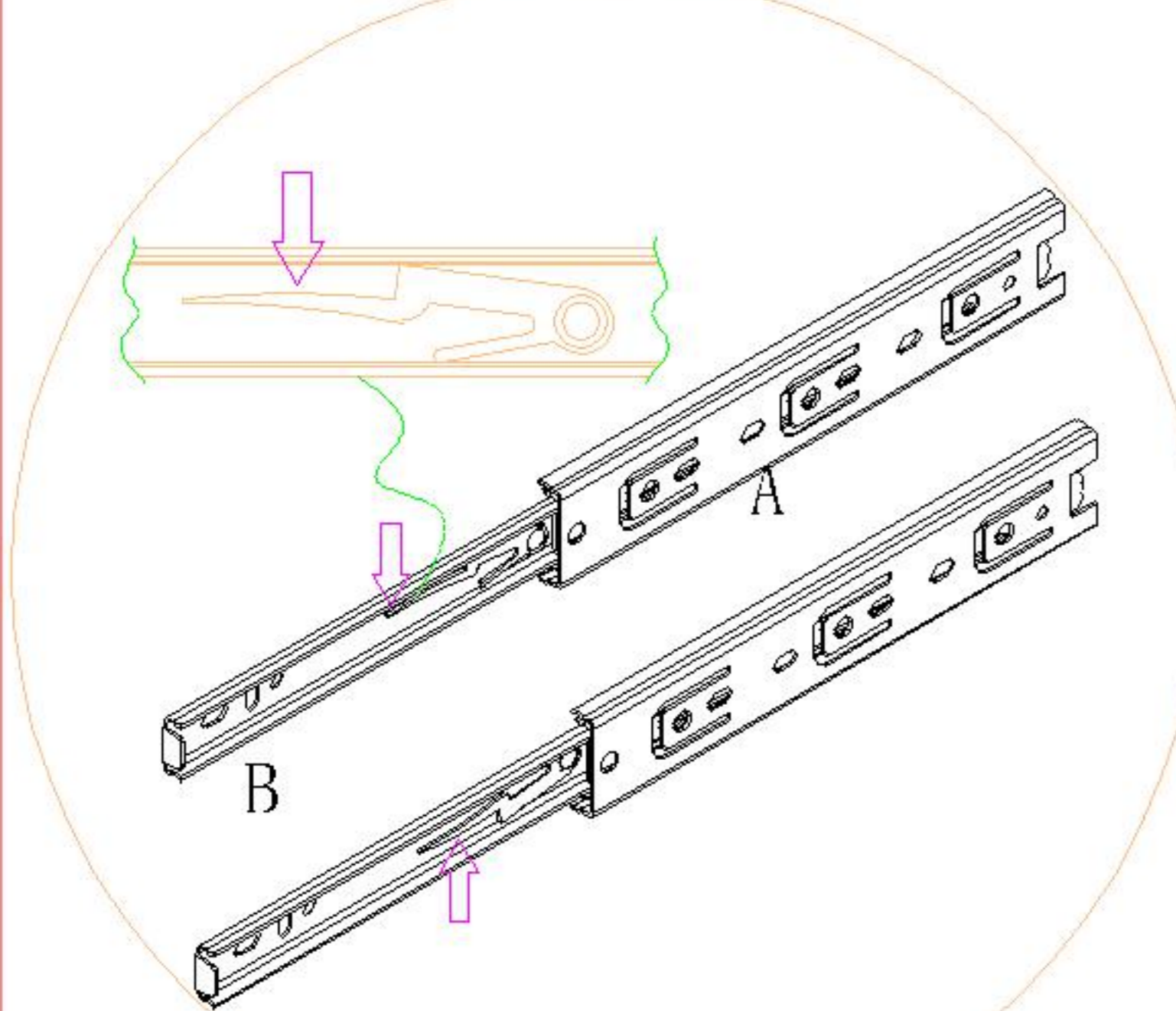

注: 先将A与B拆下来
Note: remove a and B first

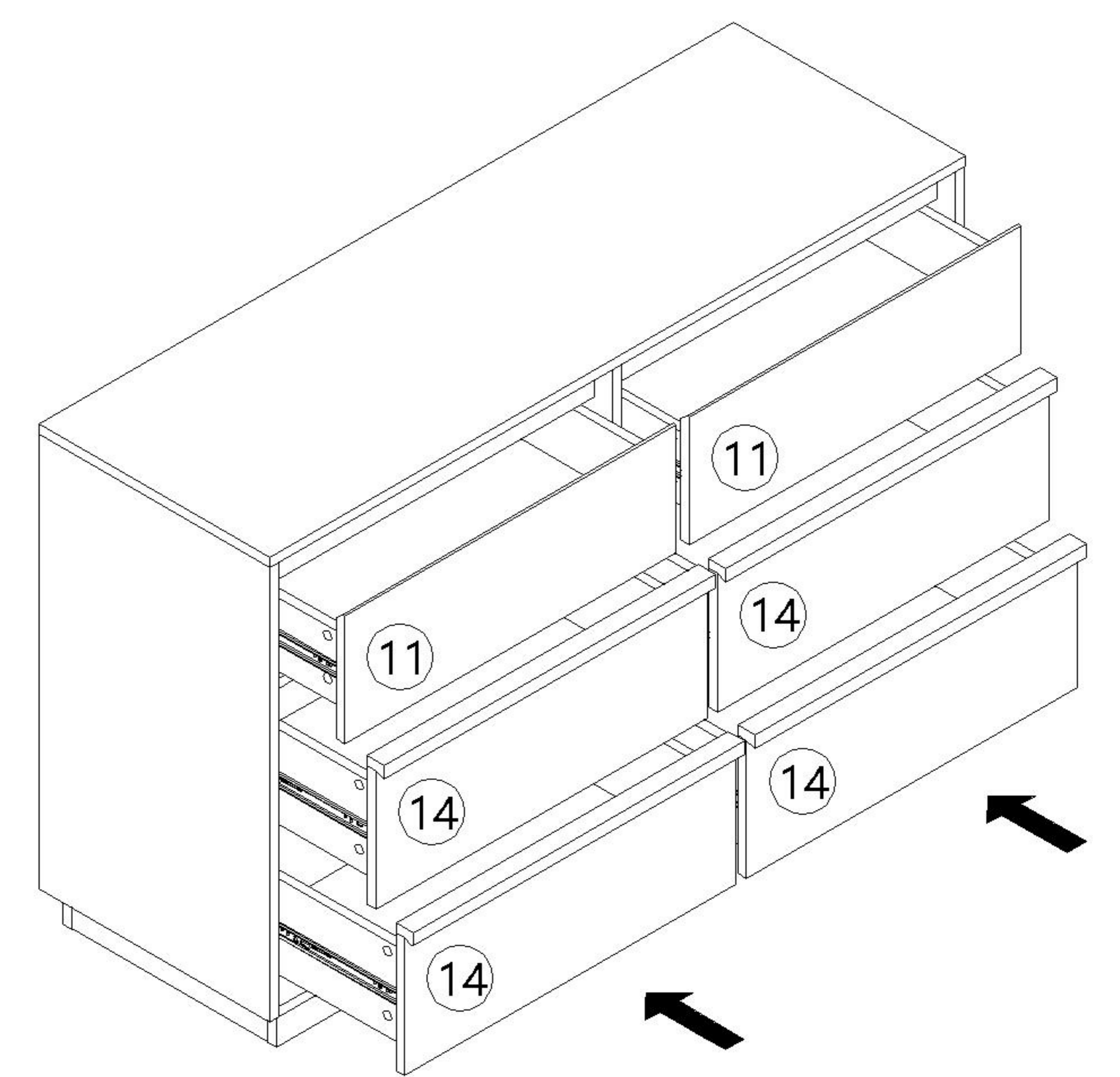
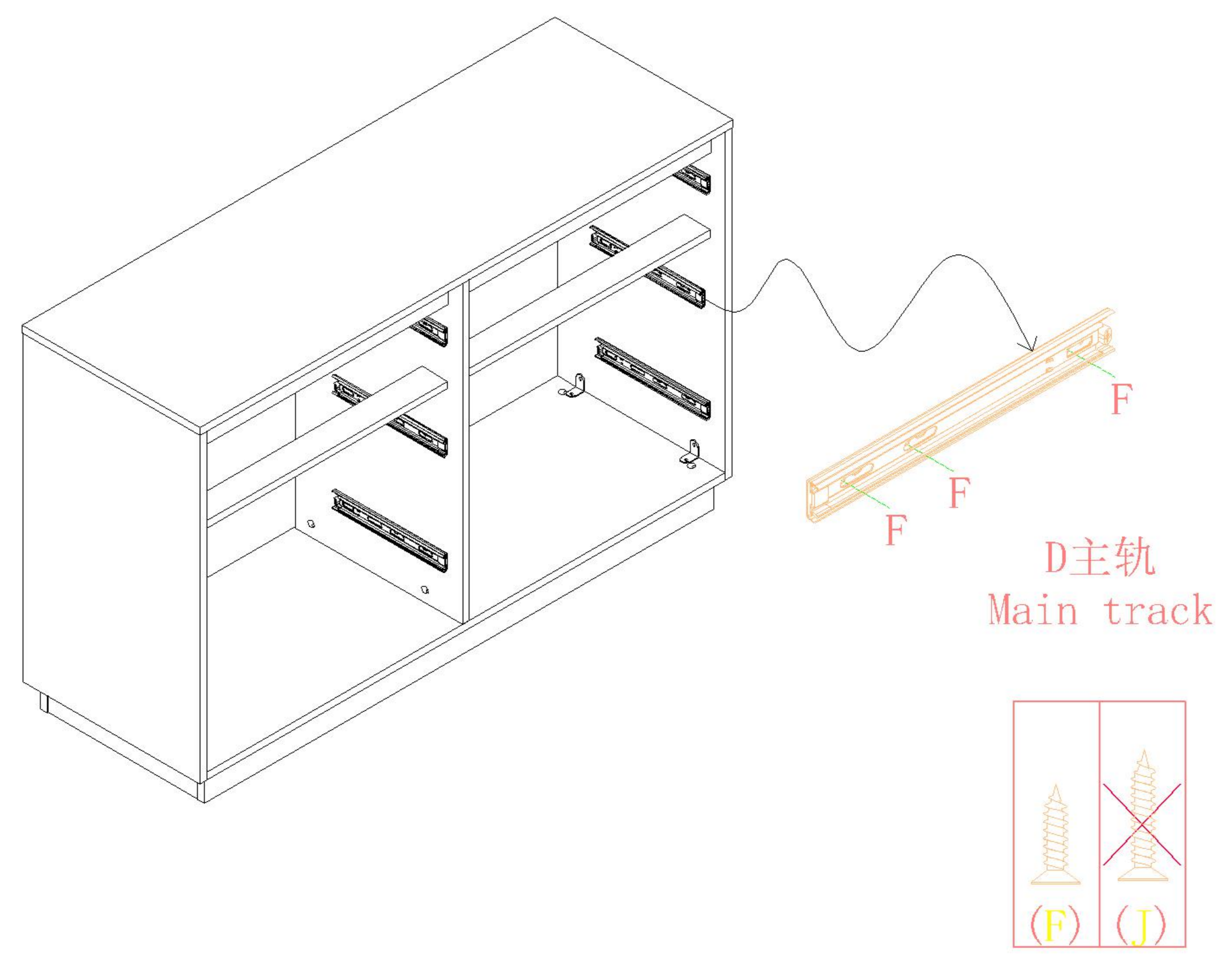
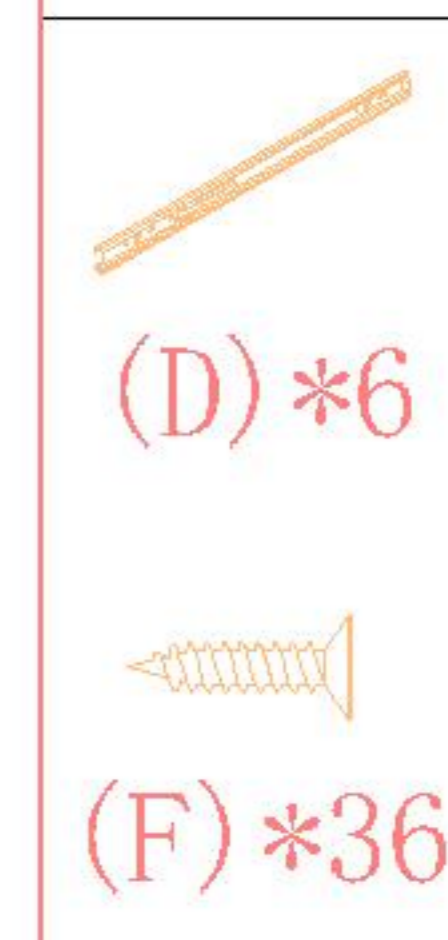
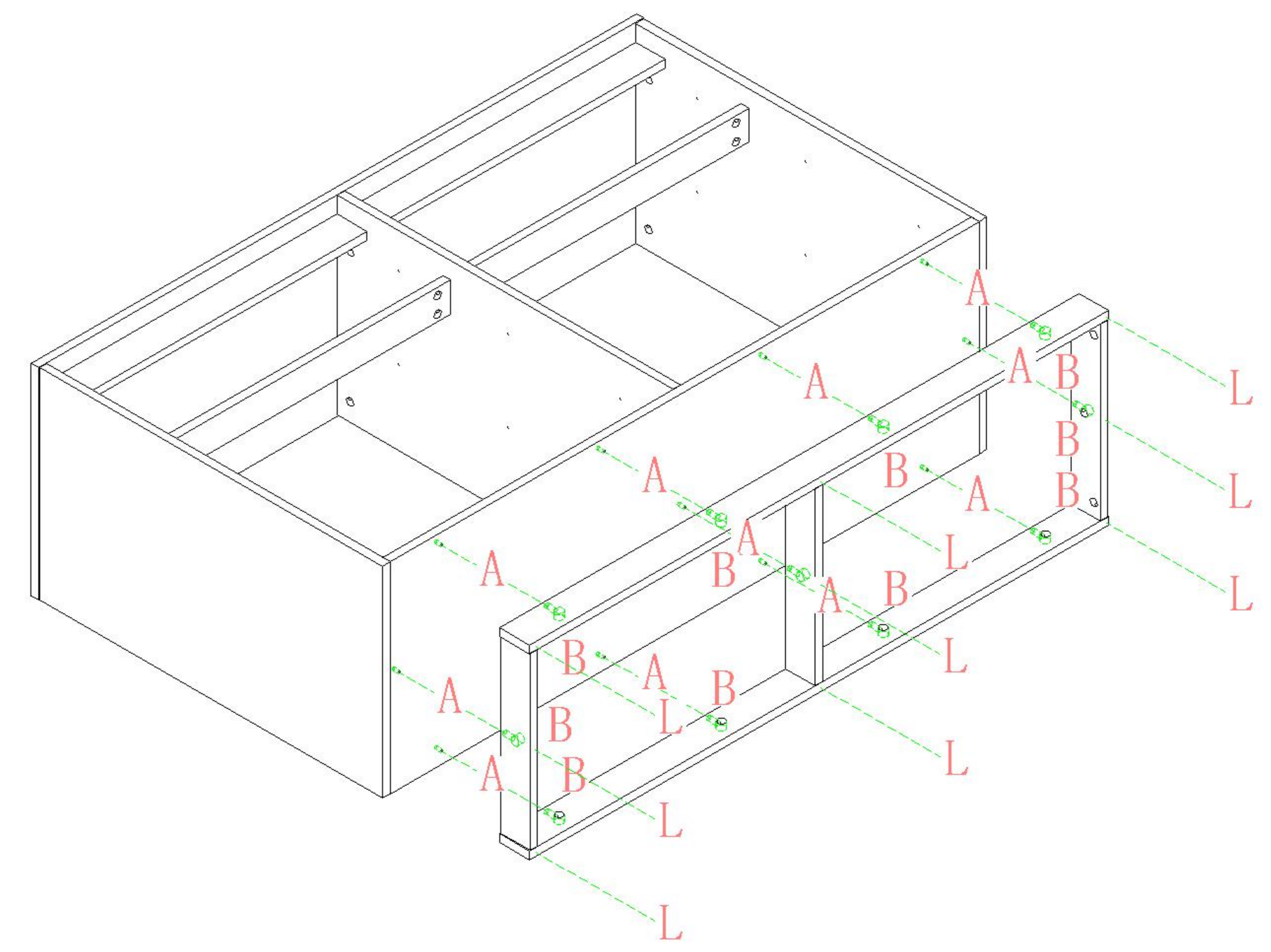
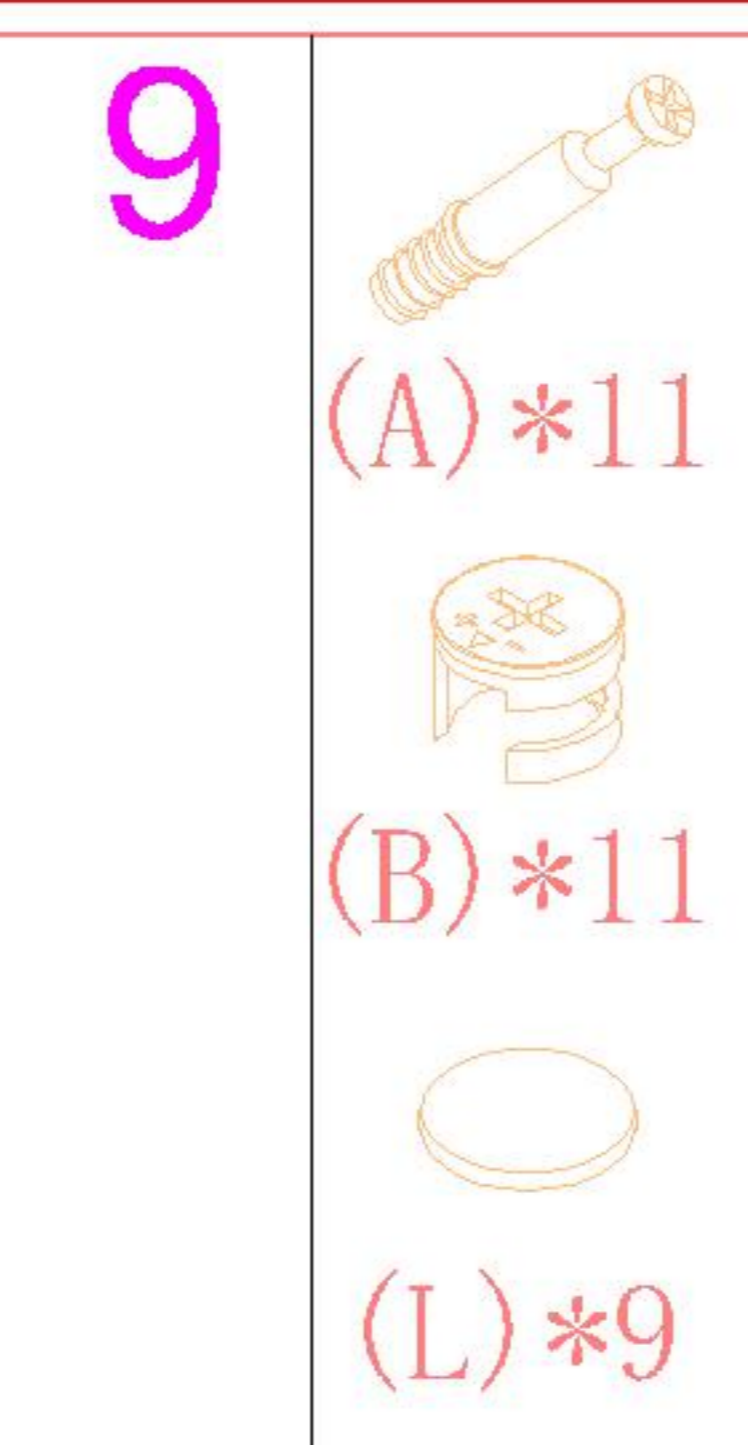
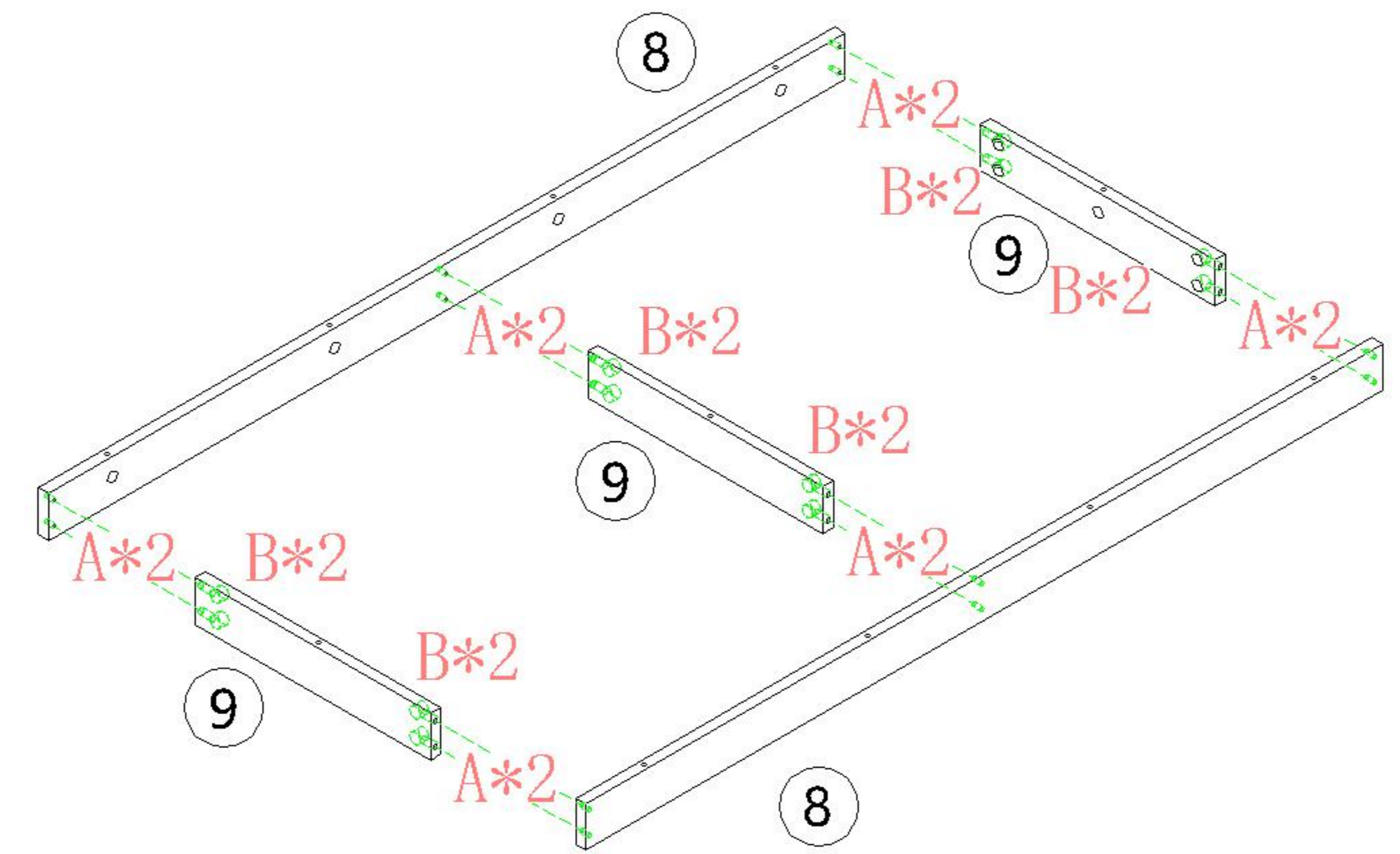
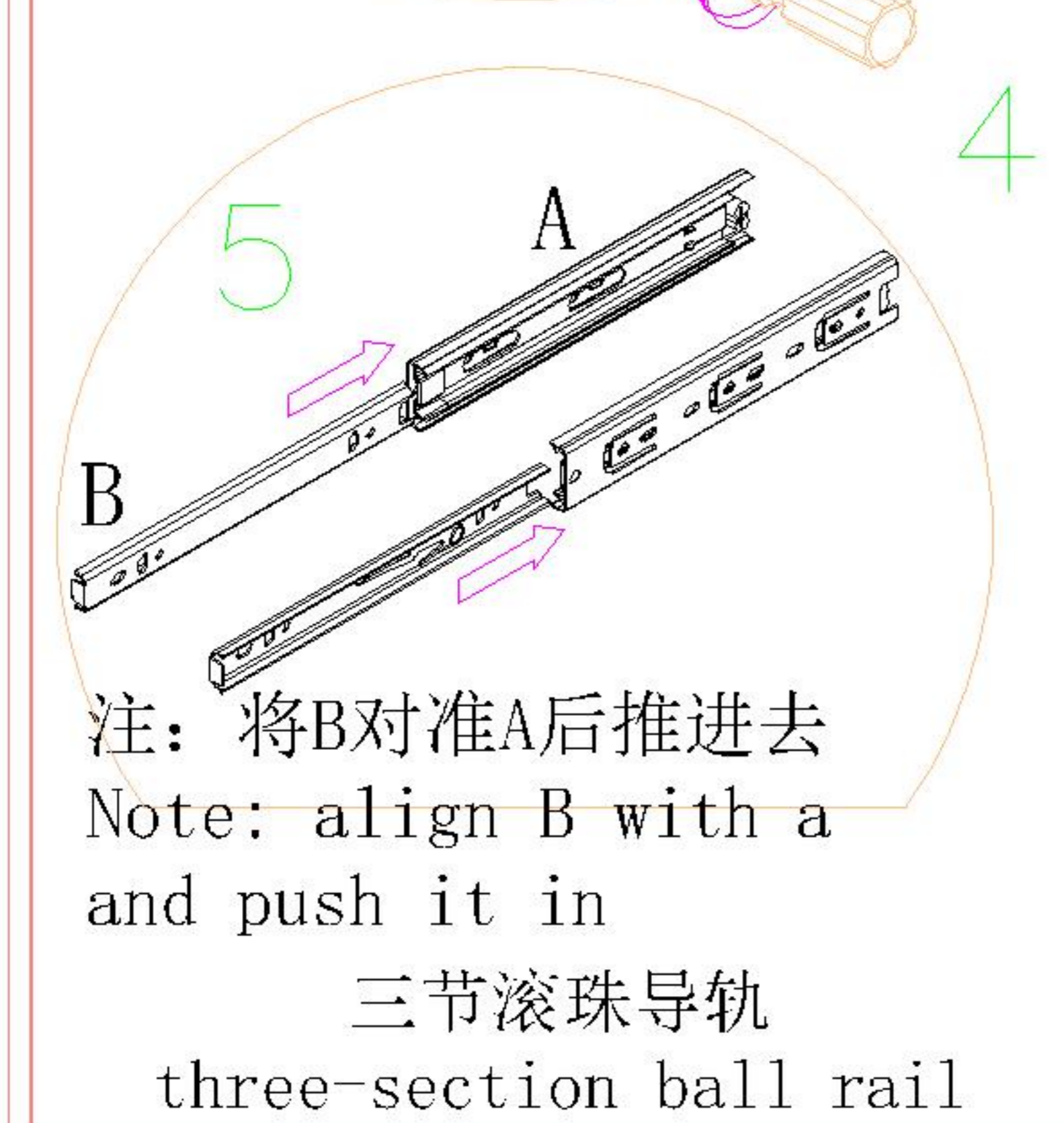
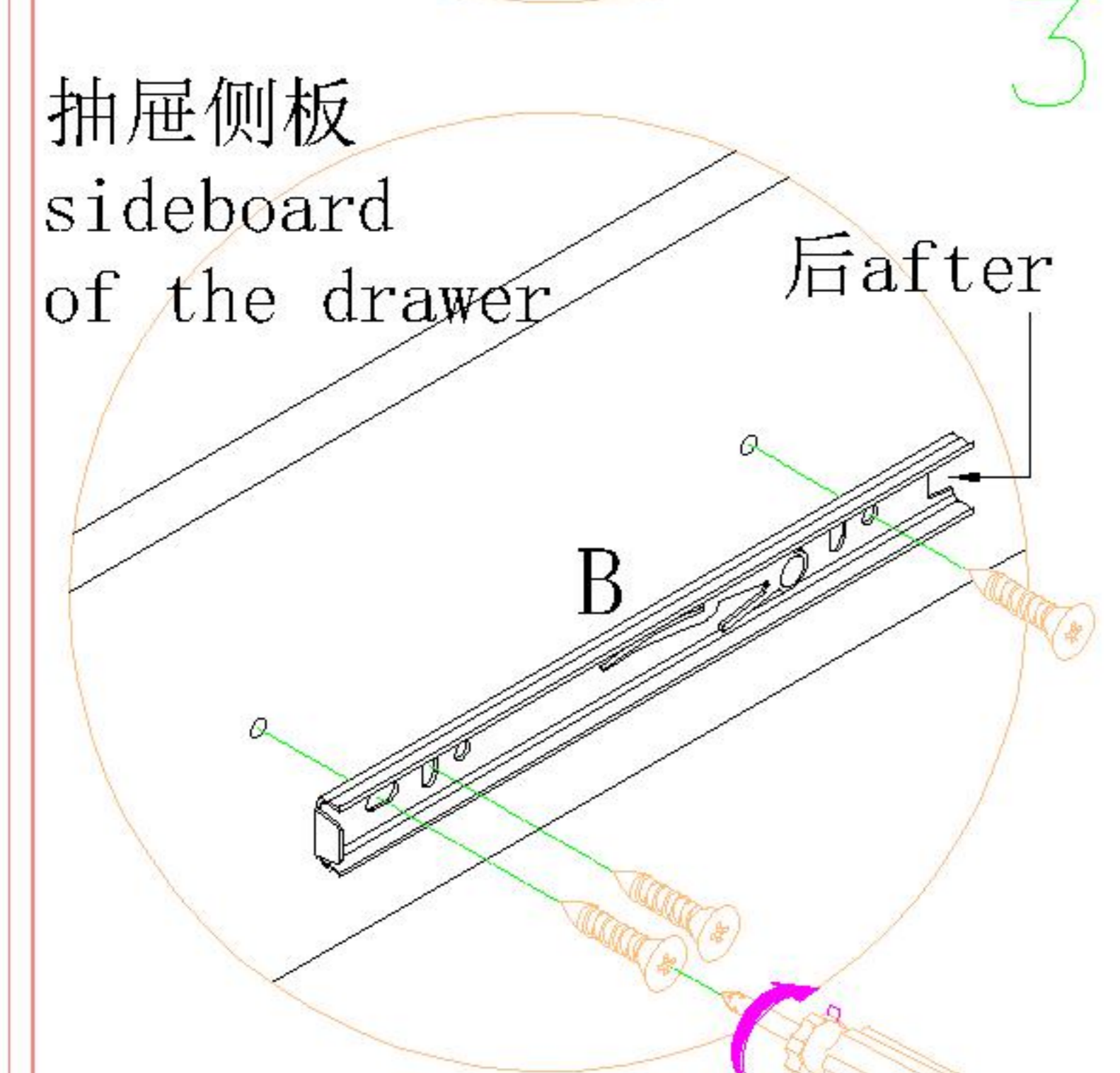
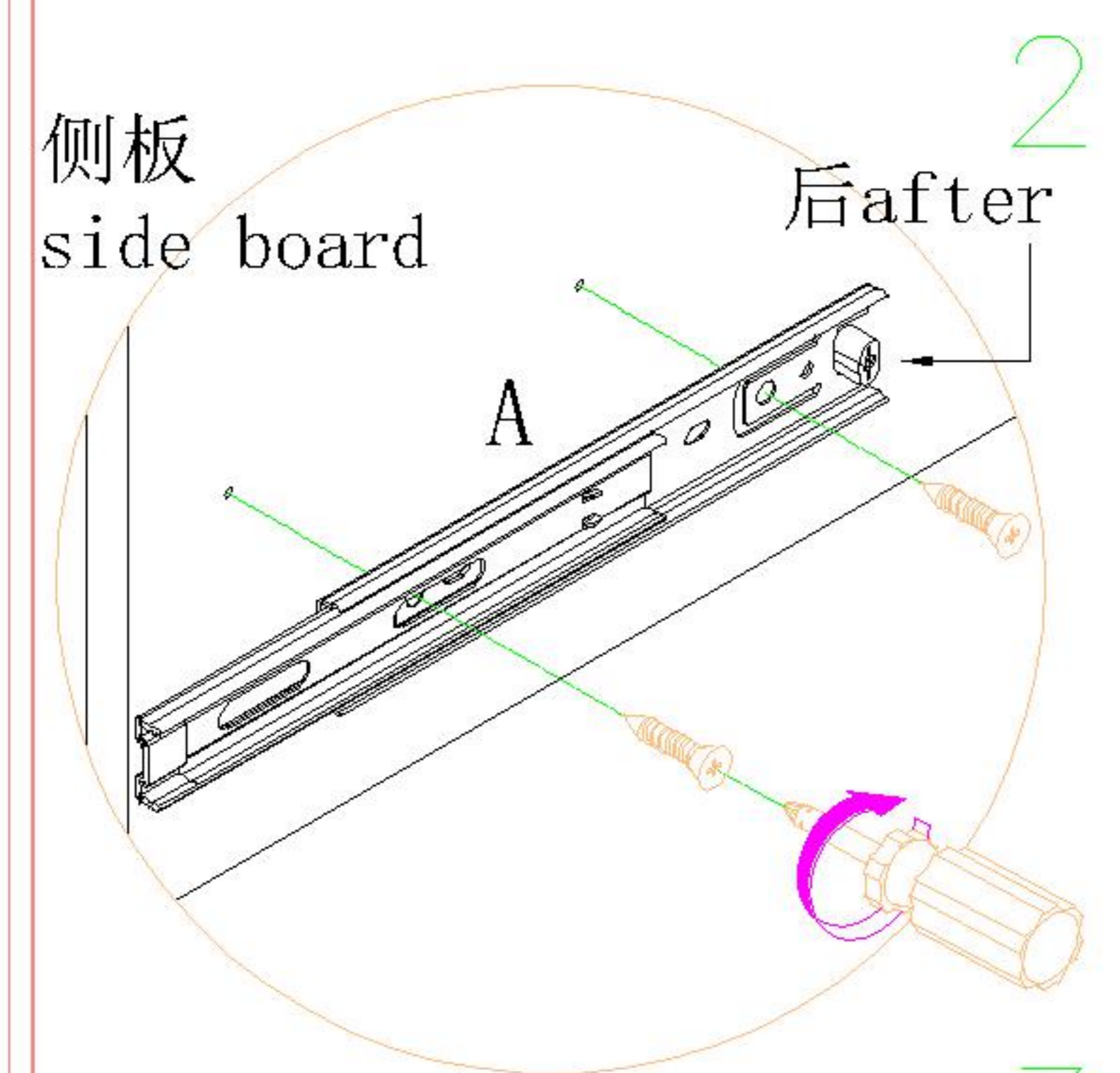

YZ1E-A 六斗柜

安装方法/
Installation method

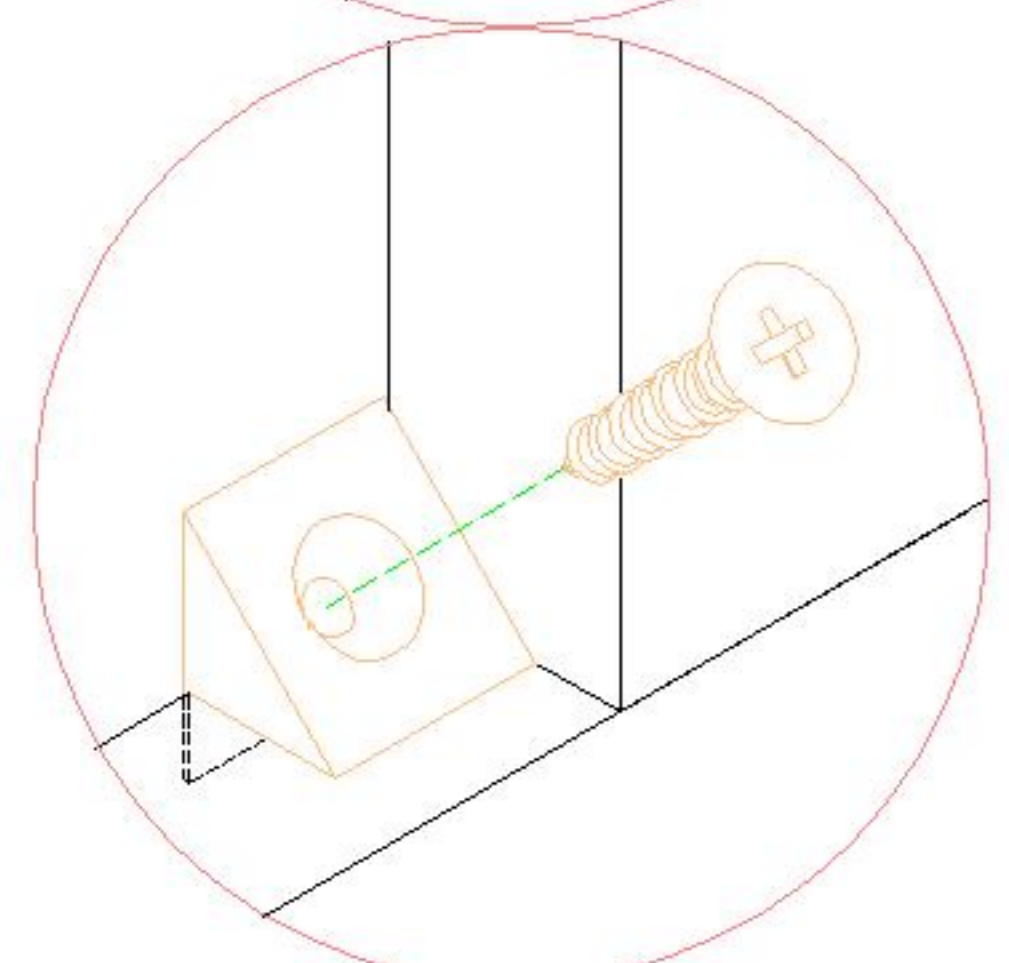
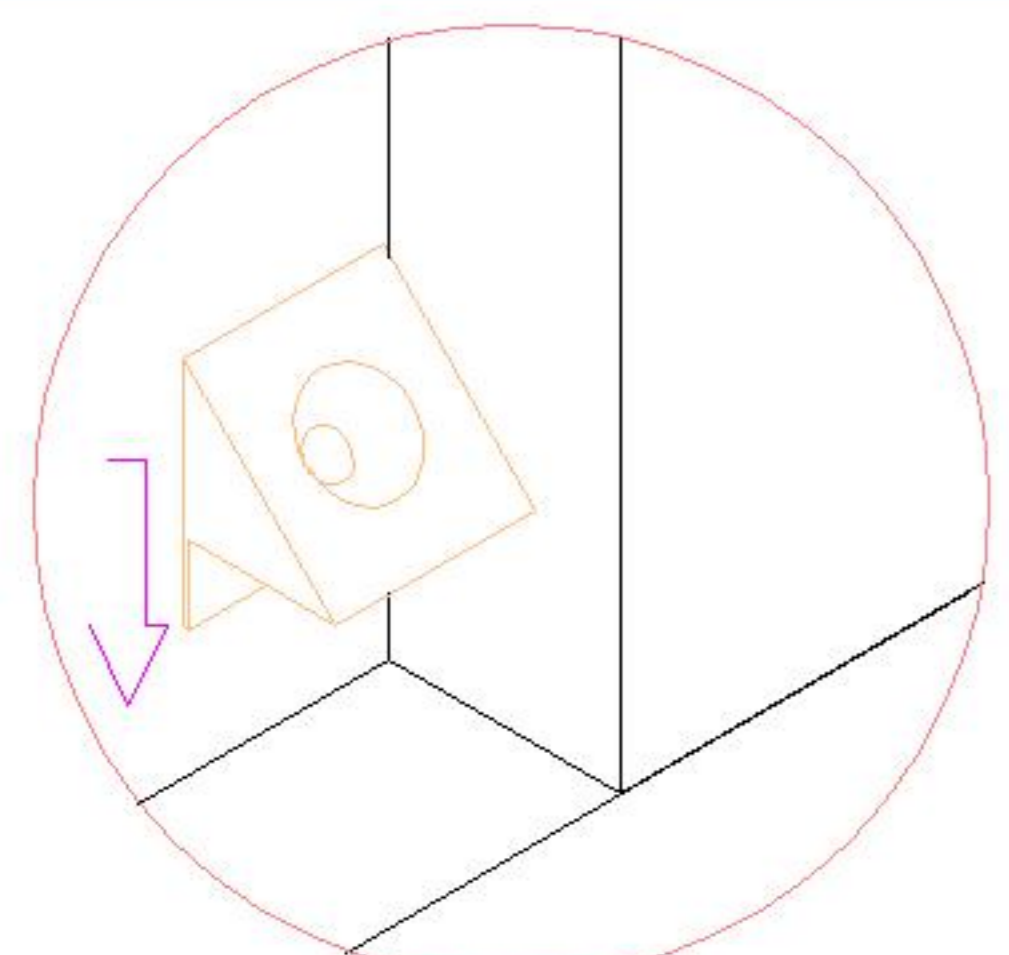

背板扣
Back Plate Buckle



(I)*12

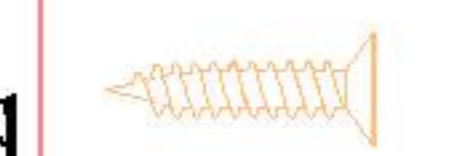

(J)*12

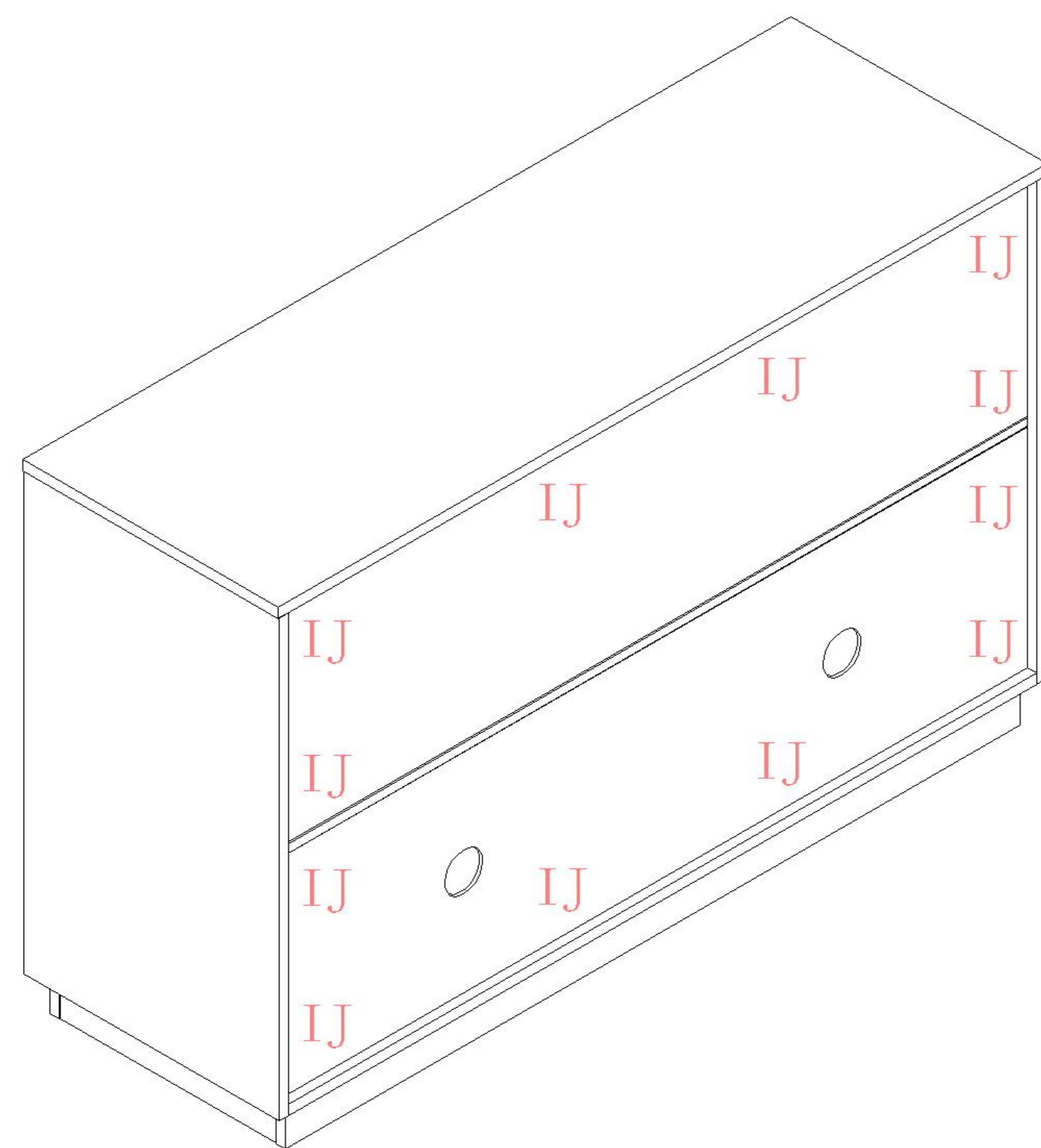

13

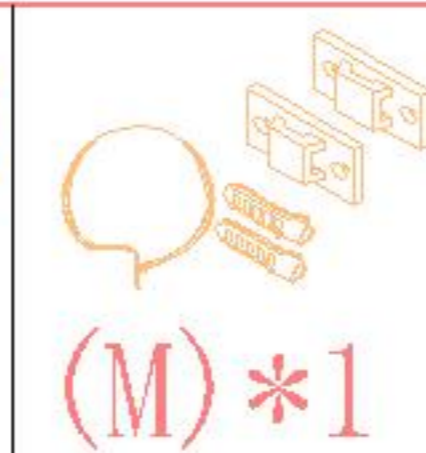

(M)*1

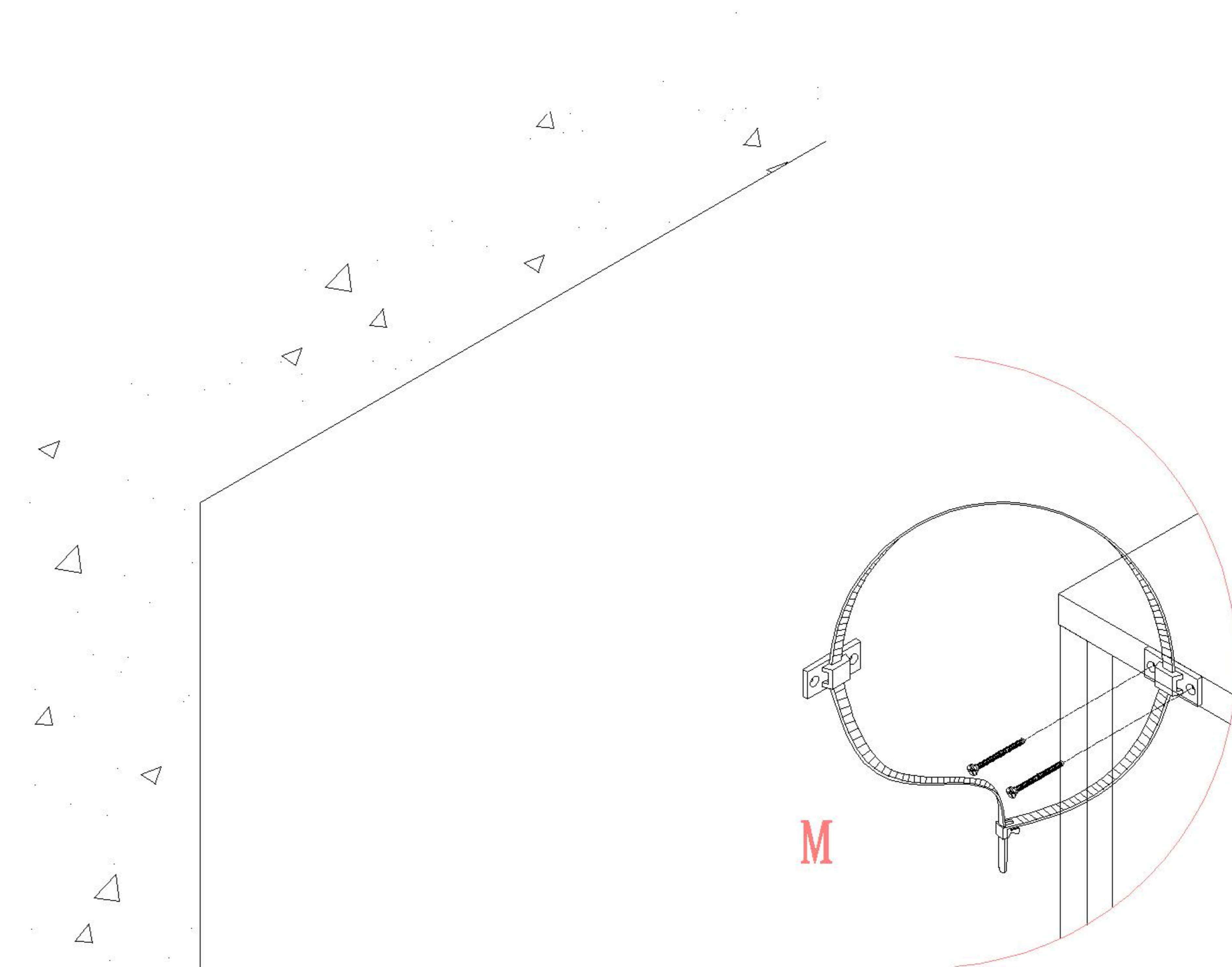

14

15

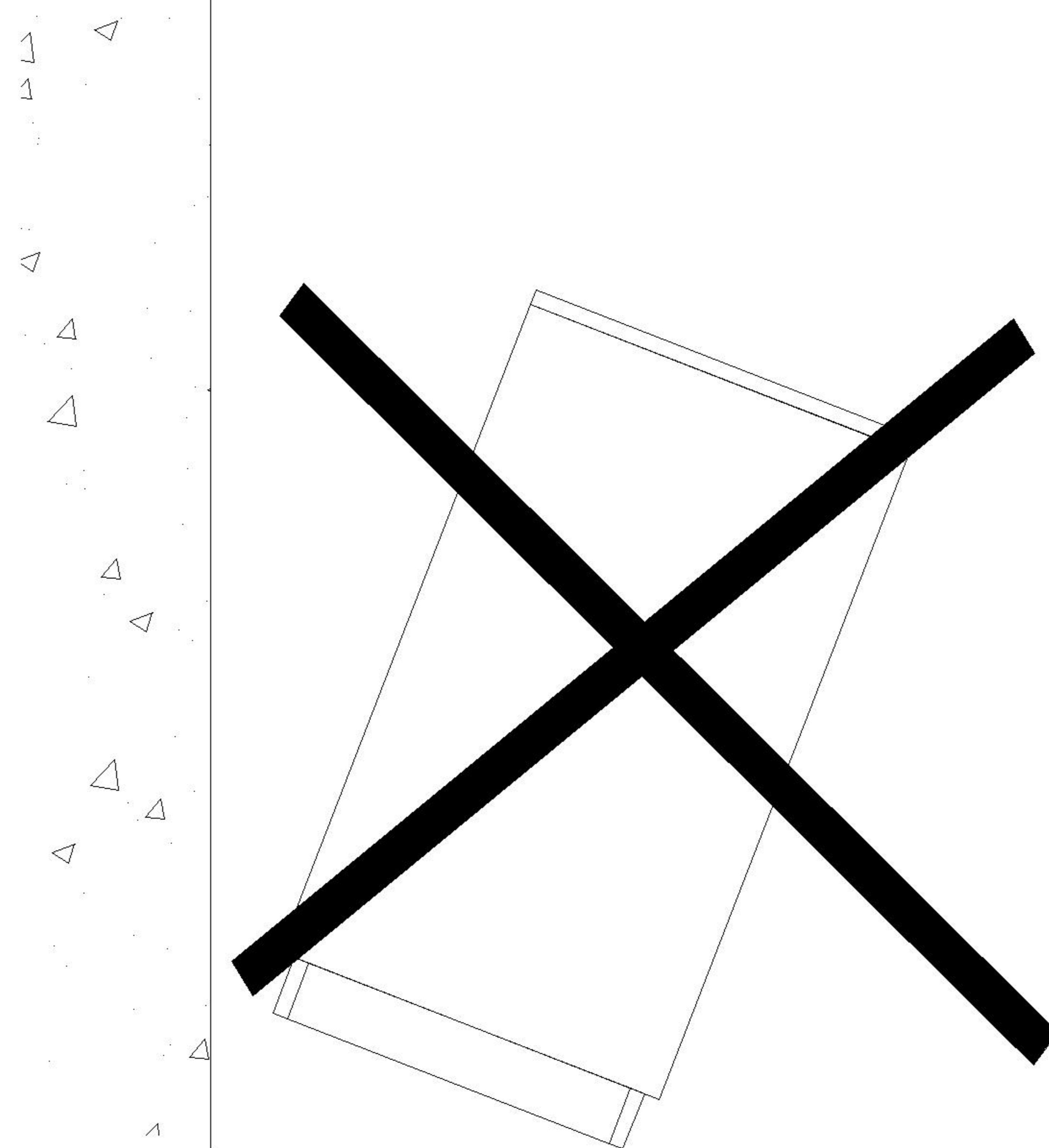

实体墙
Solid wall

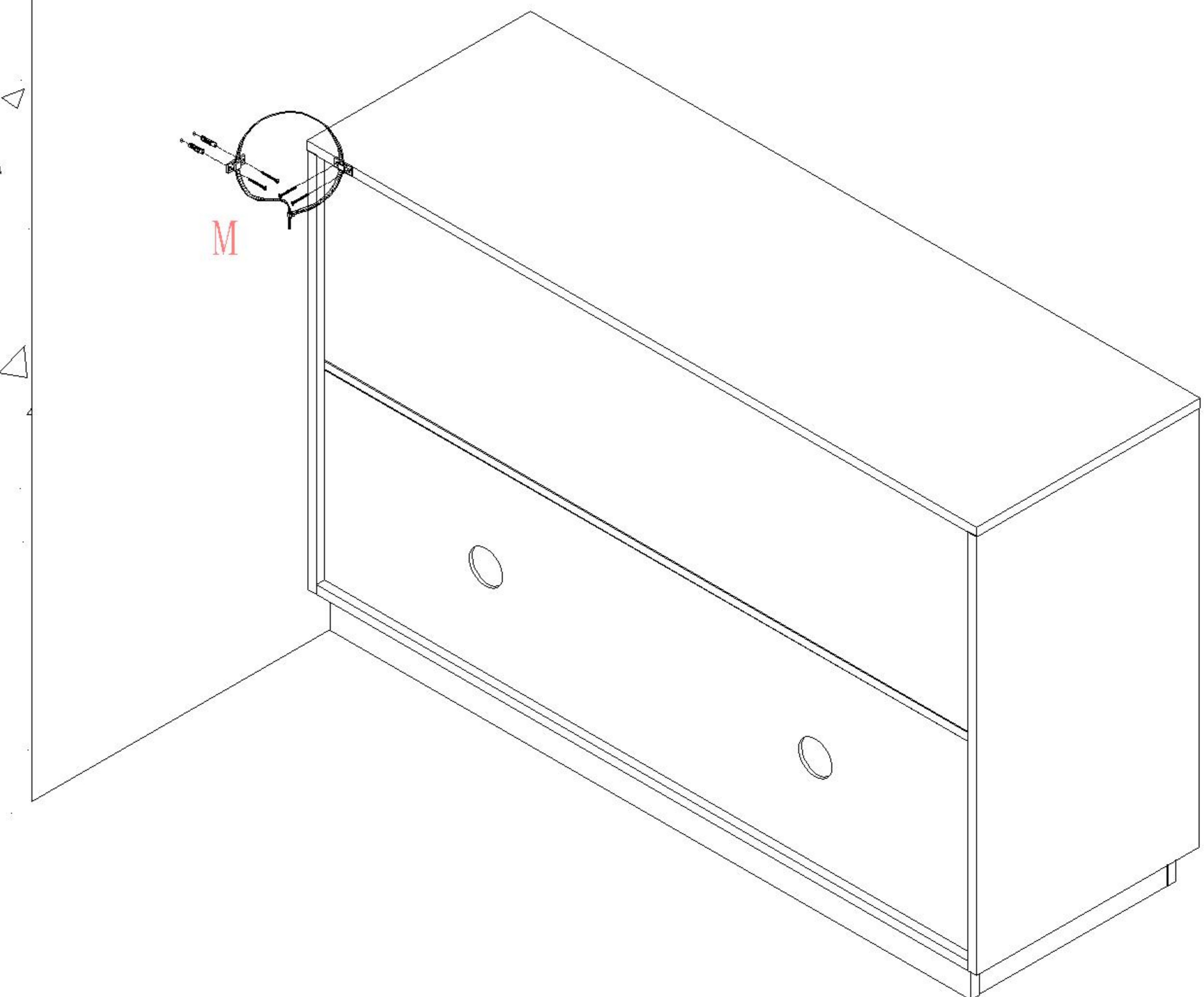

LINSY 林氏家居

五金表/Hardware list

部件表/Parts List

安装示意图/Assembly Instruction

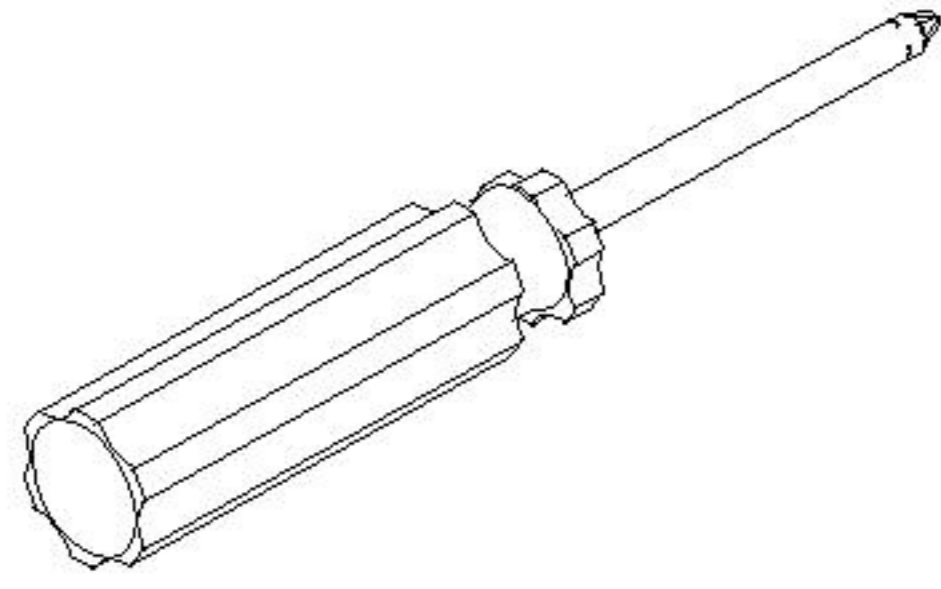
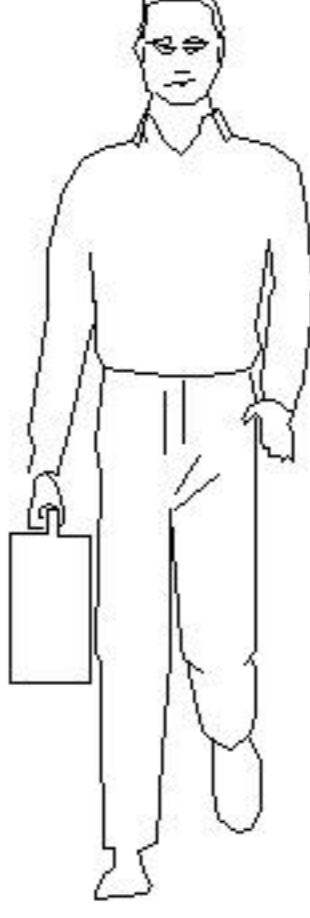
产品名称 Model NO.	L型桌
产品型号 Product Model	YZ1V-A
尺寸规格 Specification	(1200*398*793)mm
安装工具 Tool	安装人数 Installer
	

注：为保证设计效果，部分尺寸为定制尺寸，不影响使用。

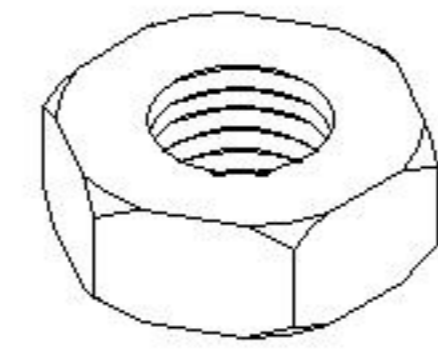
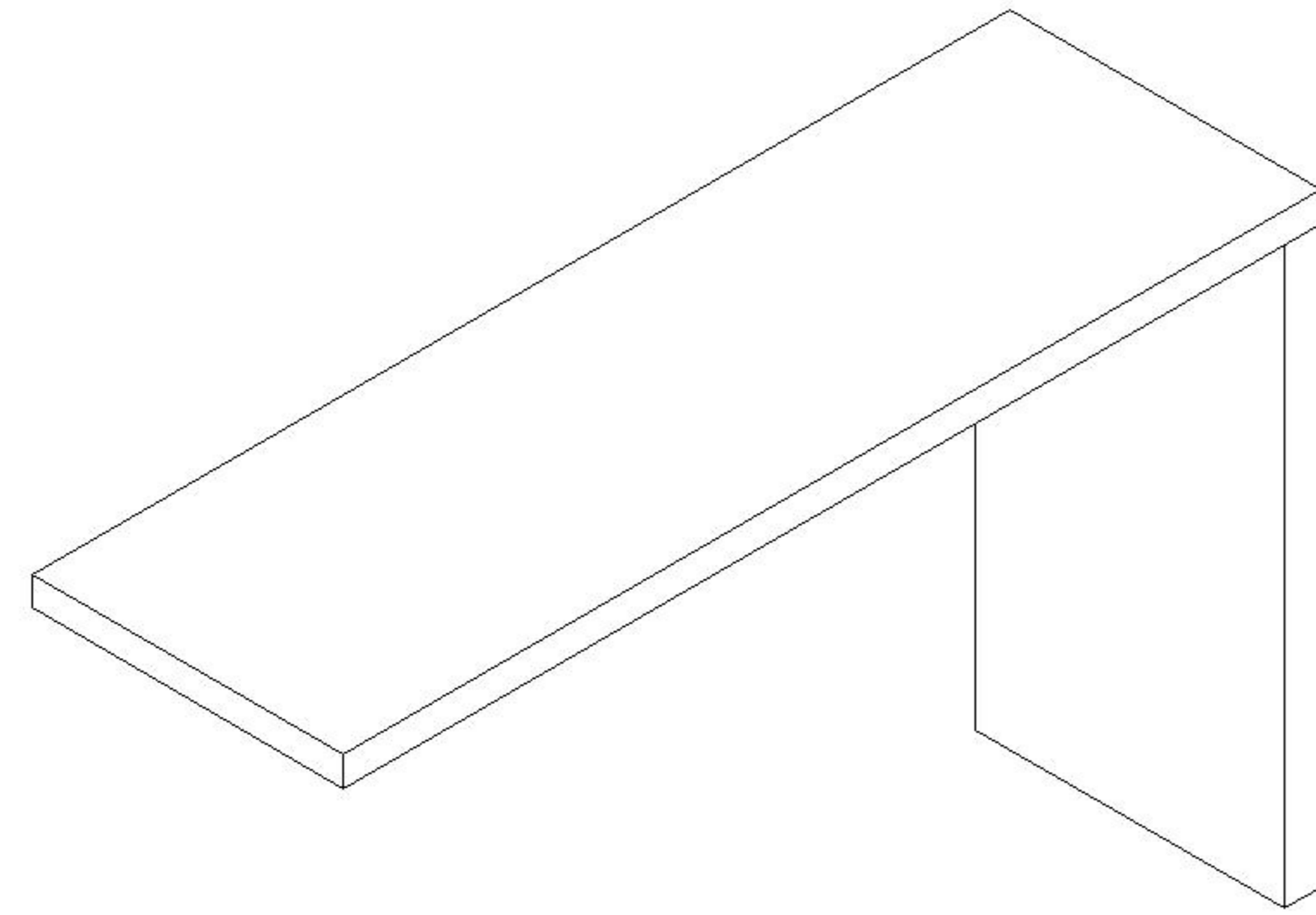

(A)* 2
外六角螺母M8
Hexagon Nut
colored zinc

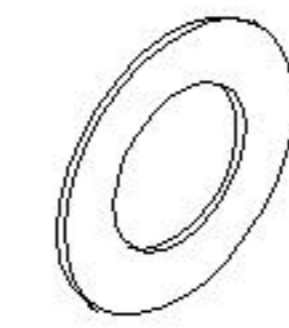

(B)* 2
垫片M8-彩锌8*17
Gasket-color zinc

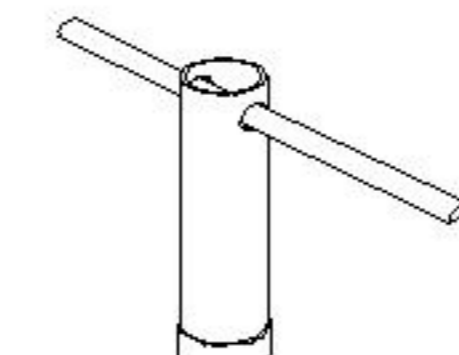

(C)* 1
套筒扳手
Socket wrench

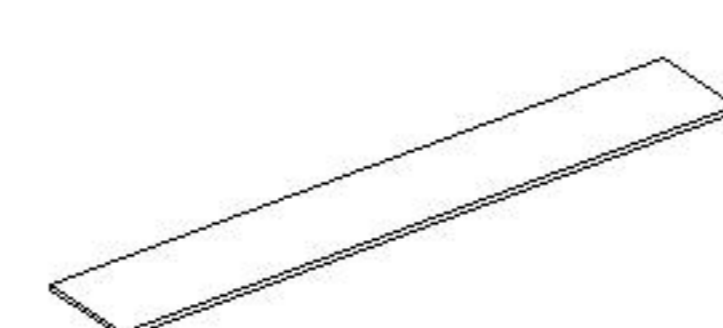

(D)* 2
垫片-黑色
Gasket - Black

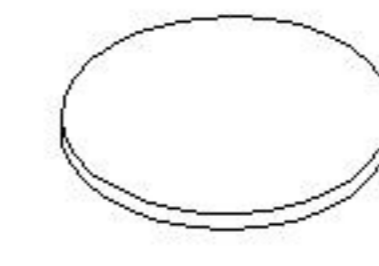

(E)* 2
脚垫
Footrest

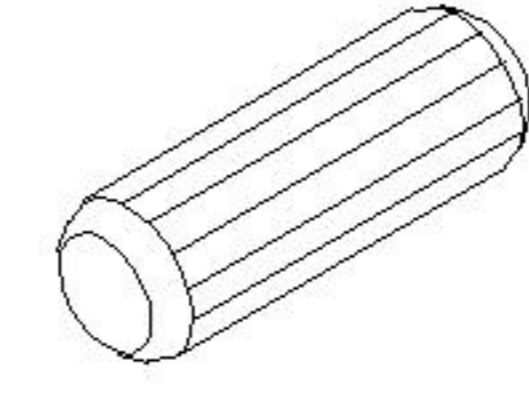

(F)* 2
木榫Ø10x40mm
wood tenon

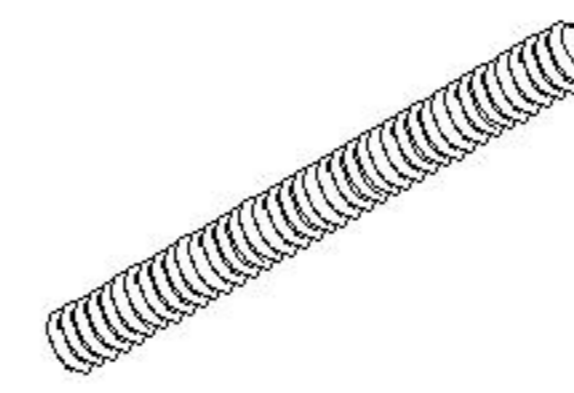

(G)* 2
全牙螺杆-M8x725mm
screw- color zinc

编号NO.	名称Name	规格 (mm) Specification	数量QTY	材质Material
①	面板 Top panel	1200*398*36	1	纤维板+刨花板Fiber board+Particle board
②	侧板 Side board	754*396*36	1	纤维板+刨花板Fiber board+Particle board

YZ1V-A L型桌

产品分解图/
exploded drawing

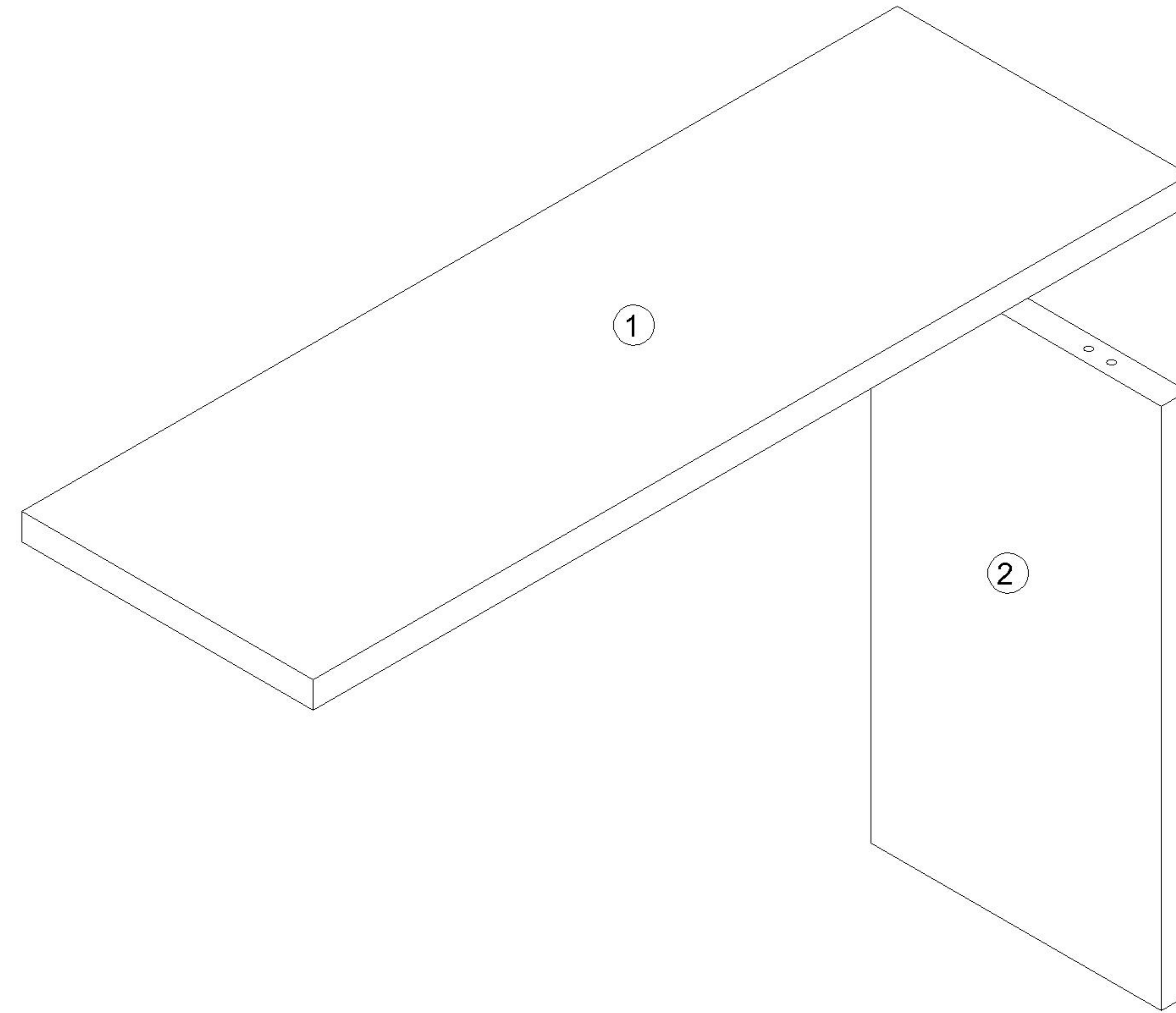

部件表/Parts List

编号NO.	名称Name
①	面板 Top panel
②	侧板 Side board





YZ1V-A L型桌

安装方法/
Installation method

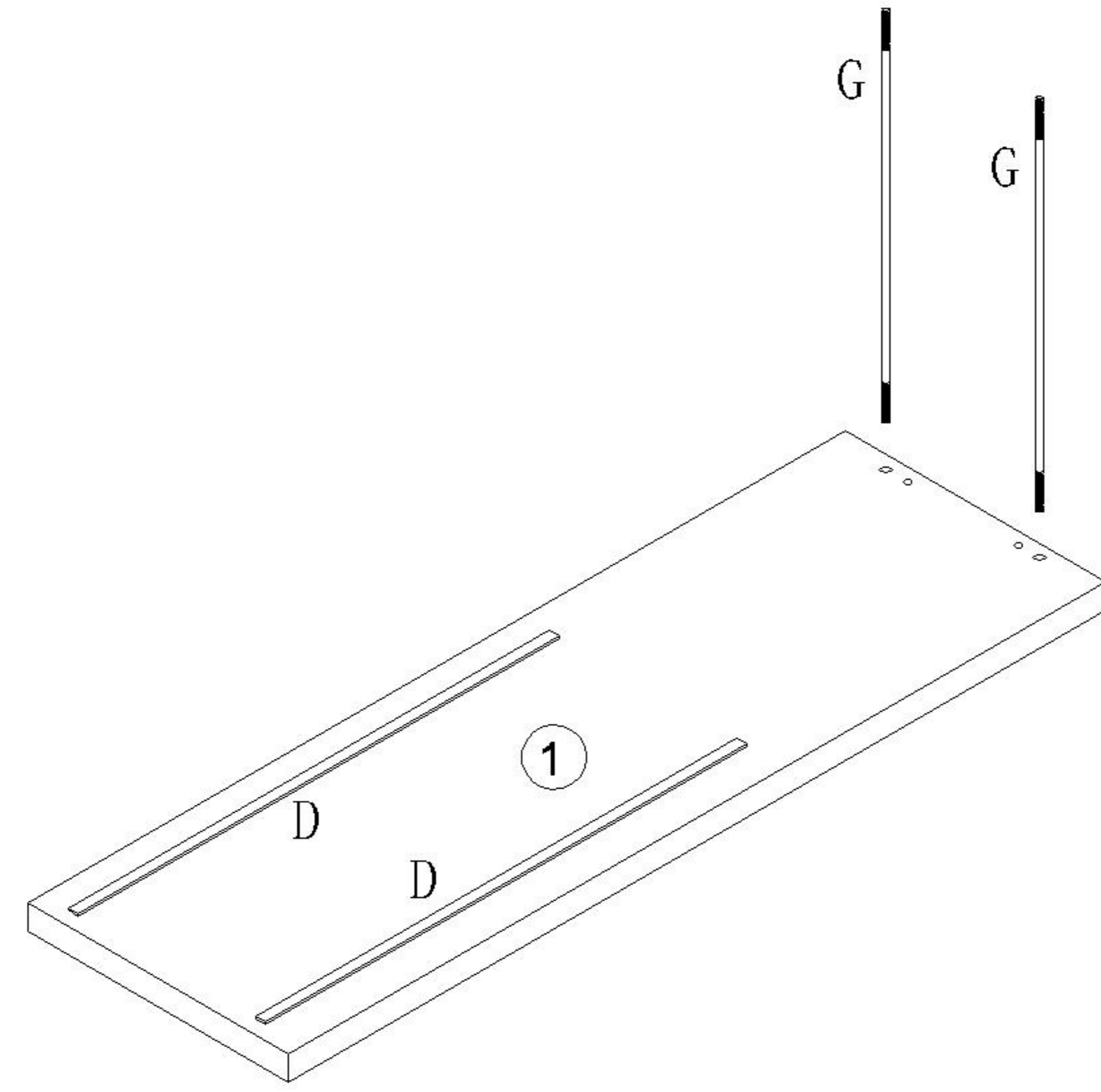
-  (D)*2
-  (G)*2



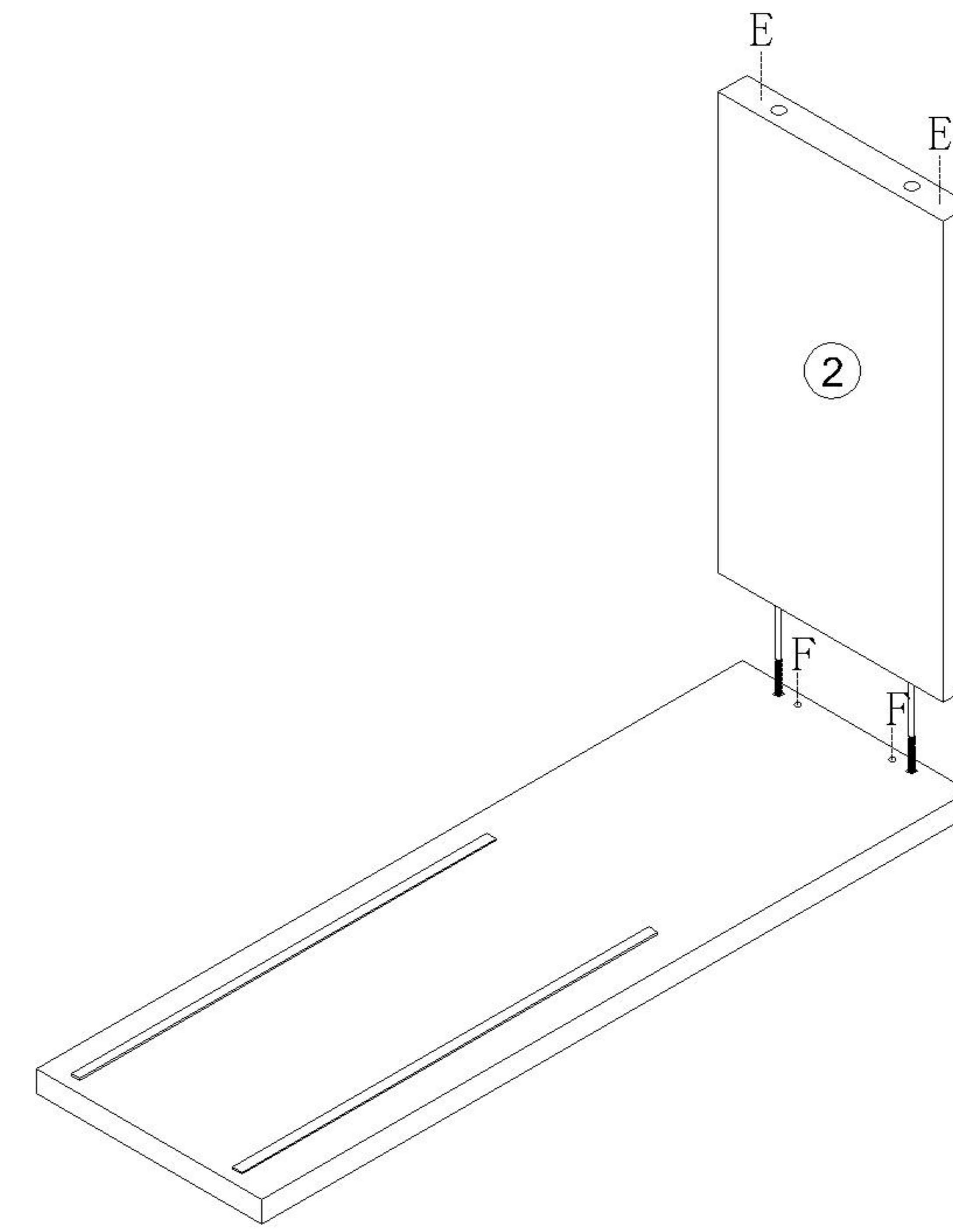

1

-  (E)*2
-  (F)*2



2

-  (A)*2
-  (B)*2
-  (C)*1

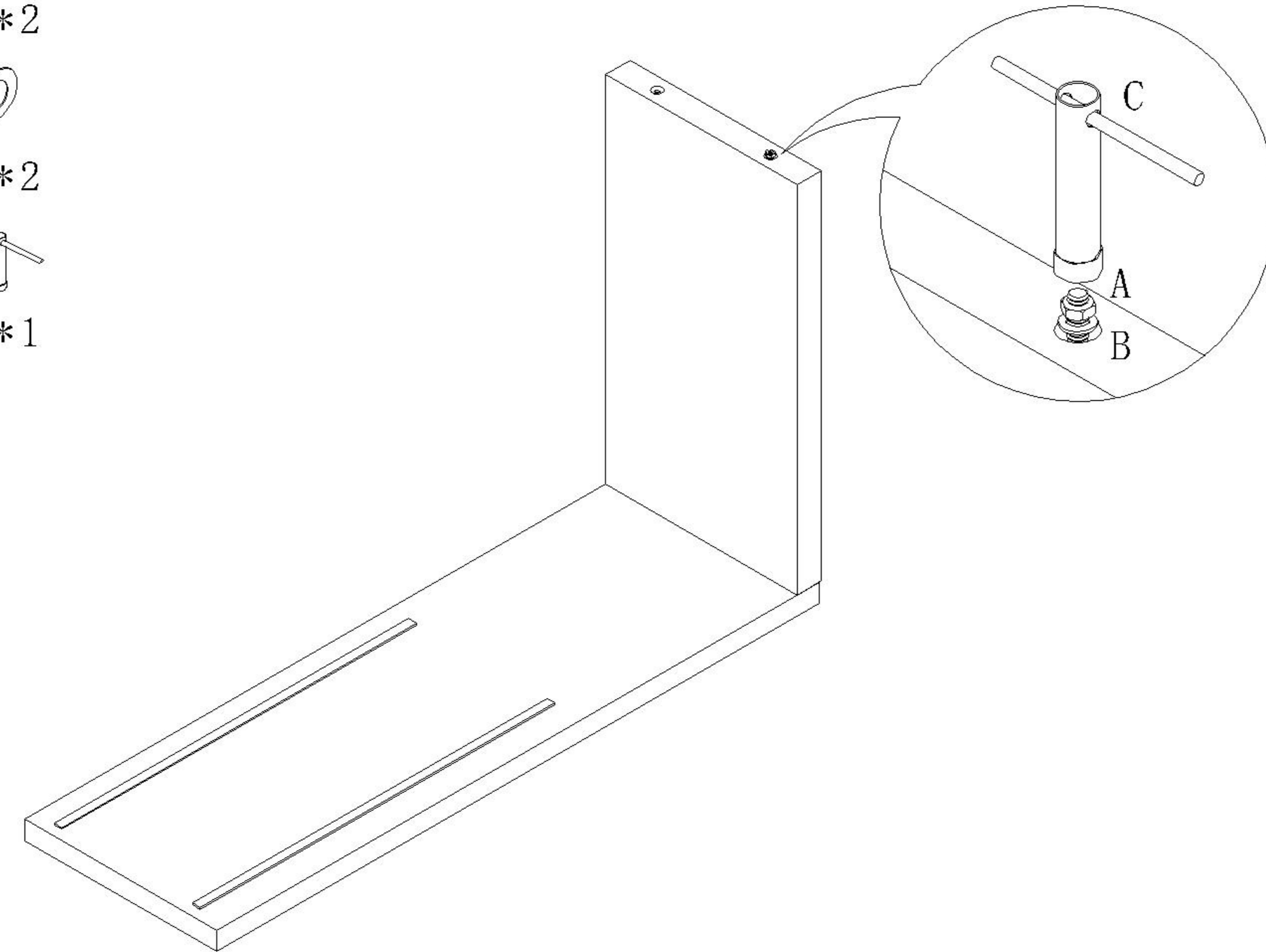

3

4

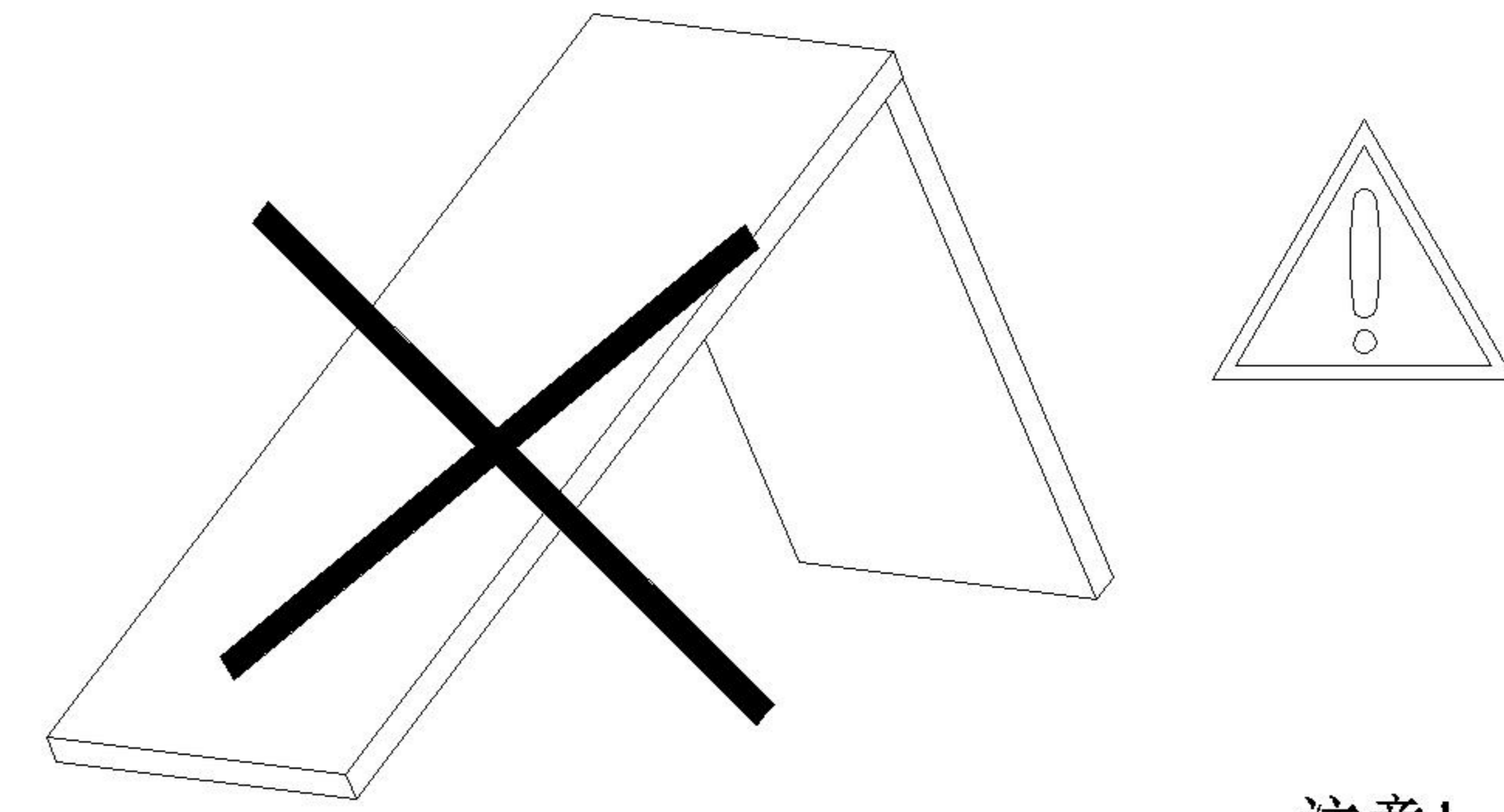

注意!
本产品需搭配组合柜使用
be careful!
This product needs to be paired with a combination cabinet for use

注意!
使用产品时请适当调整主柜与边柜组合间距离，单独放置会有倾倒的风险。
Be careful!
Please properly adjust the distance between the attached and main cabinet. Placing the main cabinet alone will have a risk of dumping.

LINSY 林氏家居

五金表/Hardware list

部件表/Parts List

安装示意图/Assembly Instruction

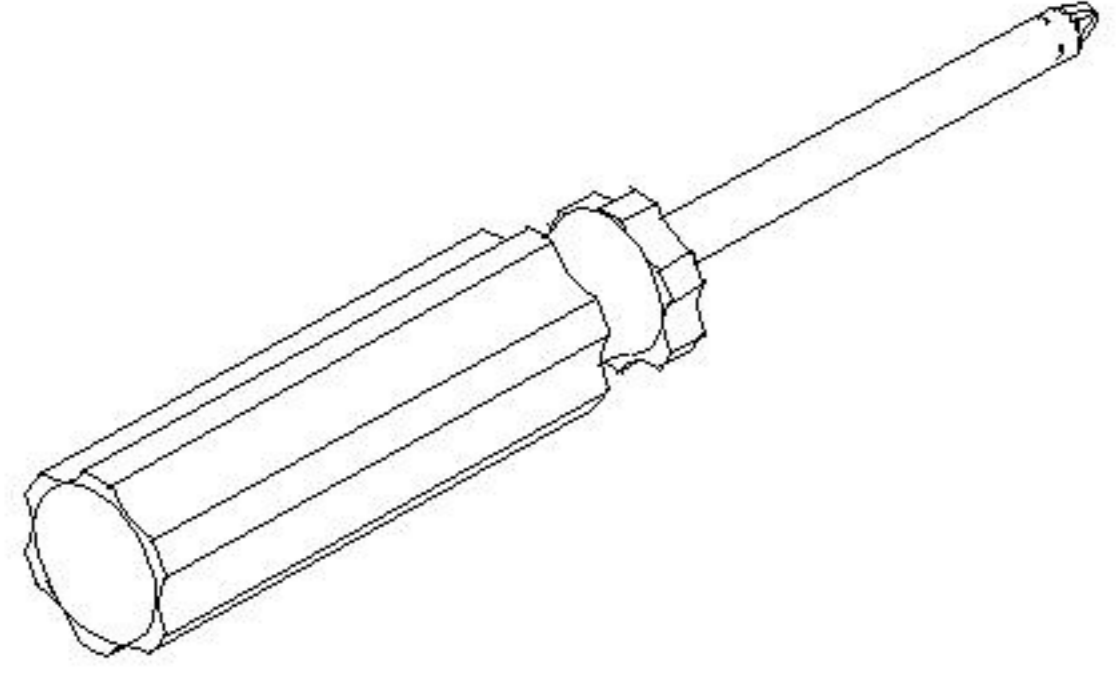
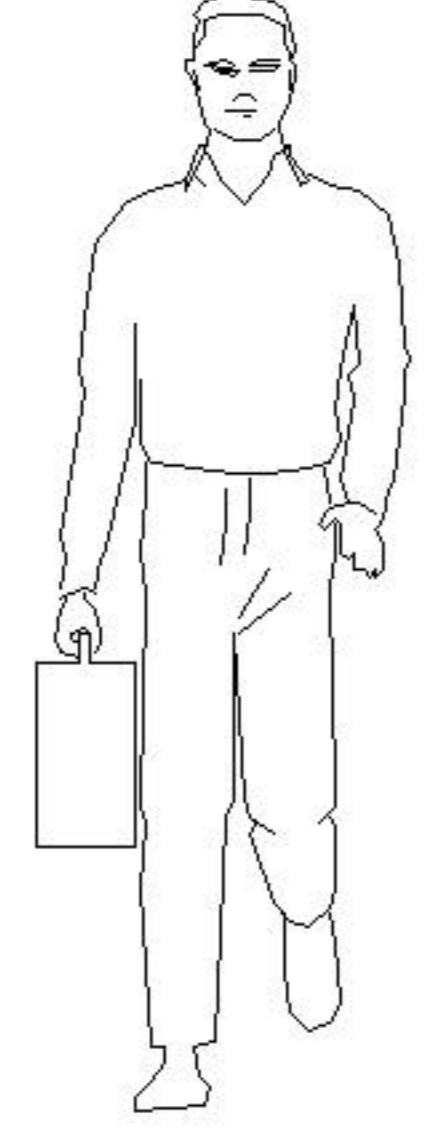
产品名称 Model NO.	方餐凳 (1把装) 胡桃色
产品型号 Product Model	UB2S-C
产品规格 Specification	395*295*458
安装工具 Tool	安装人数 Installer
	

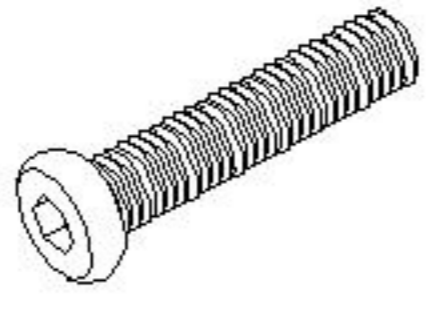
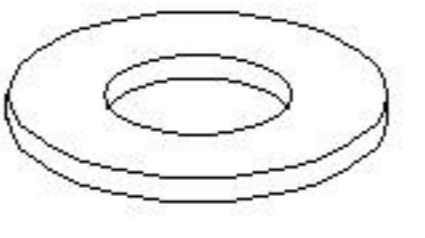
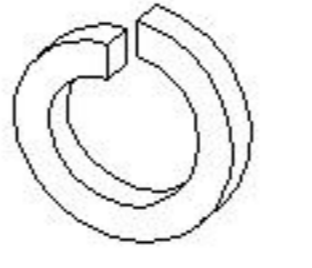
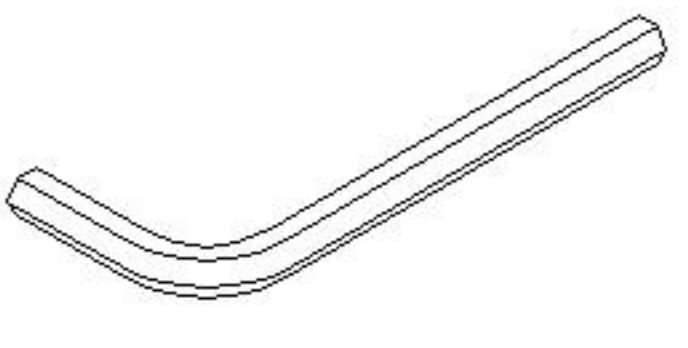
			
(A)*8 内六角丝杆 M6*45 Screw rod-(M6*45)	(B)*8 平垫 $\phi 6*18*1.2$ Flat cushion-($\phi 6*18*1.2$)	(C)*8 弹簧垫圈 $\phi 6$ Spring pad-($\phi 6$)	(F)*1 六角扳手 4# Wrench-(4mm)

编号NO.	名称Name	规格 Specification	数量QTY	材质Material
1	底框 Bottom frame	366*266*60	1	橡胶木 Rubber wood
2	脚 foot	410*75*35	4	橡胶木 Rubber wood
3	软包座板 Soft-padded seat board	395*295*42	1	多层板+海绵皮料 Multi-layer board +leather material

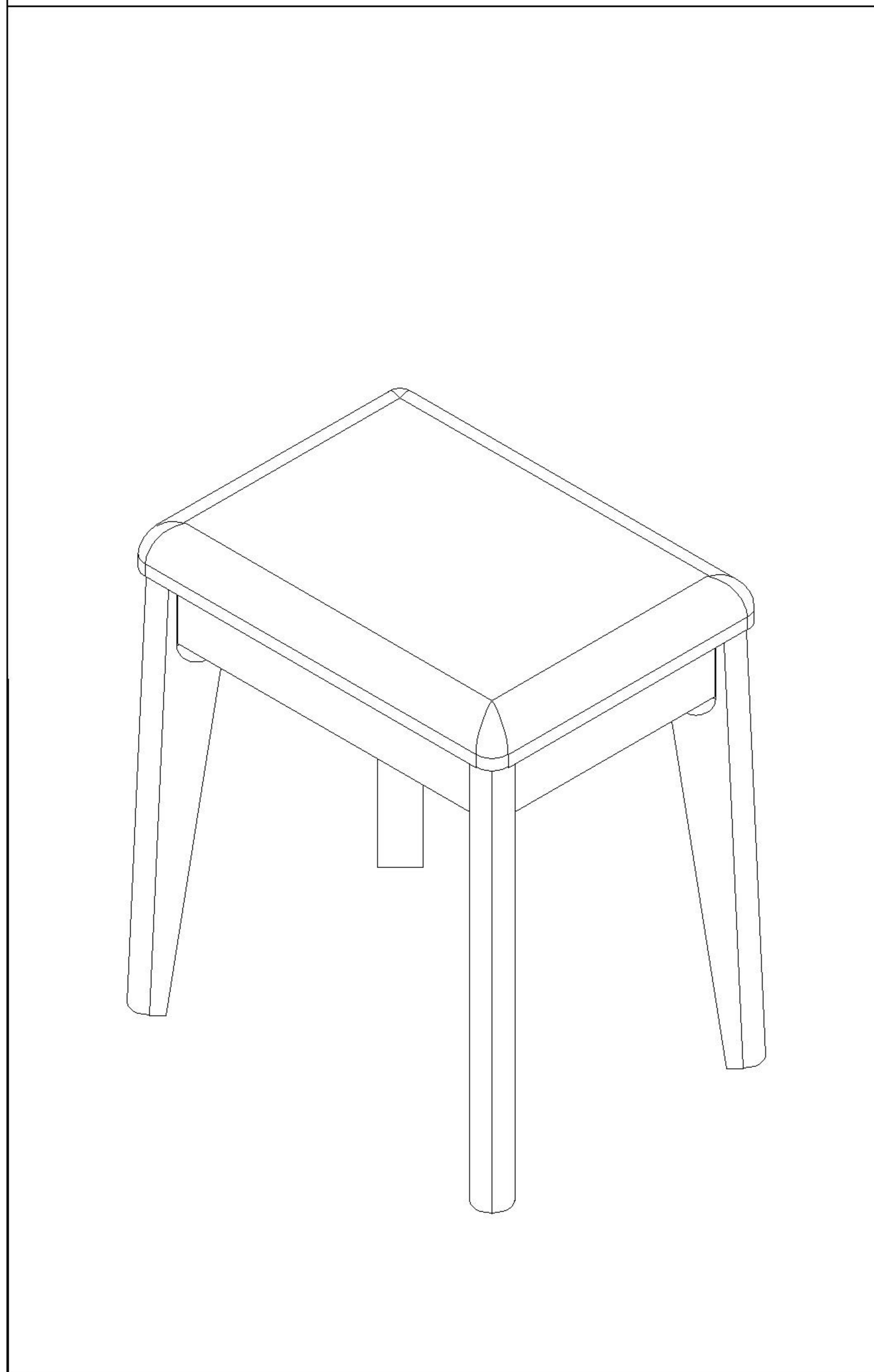

UB2S-C

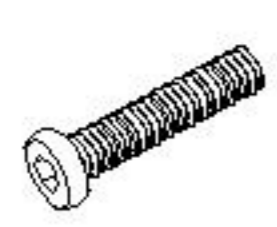

(A)*8

安装方法/
Installation method



(C)*8

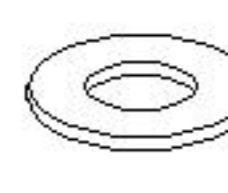

(B)*8



(D)*1

