

LINSY 林氏家居

安装示意图 / Assembly Instruction

产品名称 Model NO.	LS857J1-B Z字造型边几 (胡桃木色) LS857J1-B(Z-shaped table) (Walnut color)	产品规格 Specification	442*360*565mm
-------------------	---	-----------------------	---------------

安装工具/Tool



安装人员 / Installer



部件表 / Parts list

编号 NO.	名称 Name	规格 Specification	数量 QTY	材质 Material
1	桌面 desktop	402*350*20	1	竹 bamboo
2	玻璃 glass	400*300*5	1	玻璃
3	侧片 Sidepiece	360*565*20	2	竹 bamboo
4	背板 backboard	402*315*20	1	竹+PVC藤编 bamboo+rattan weaving
5	拉档 cross rail	400*45*12	1	竹 bamboo

五金表 / Hardware list

编号 NO.	名称 Name	图示 Illustration	数量 QTY	材质 Material
A	内六角过山丝 internal hexagonal screw	M5*40	10	镀锌 nickeling
B	硅胶垫 silicone pad		4	硅胶 silica gel
C	内六角扳手 hexagon bar wrench	3#	1	镀锌 nickeling

当心夹手 / Watch Your Hand

安装时请勿将手伸入缝中，以防夹手。

Do not reach into the gap during installation to prevent getting fingers pinched.

温馨提示：

步骤中，拉开或安装过程中卡住时，请勿使用蛮力拉开，以免造成产品损坏。

Do not use brute force to pull apart or install when get stuck to avoid product damage.

※ 亲 请您在安装时注意每个五金不要一次性旋紧，需等所有的五金组装到位再固定旋紧。

Please level it and tighten it once

安装步骤 Installation steps

- ① 如图先把五金A固定好部件1与3。
As shown in the figure, first fix hardware A to component 1/3.

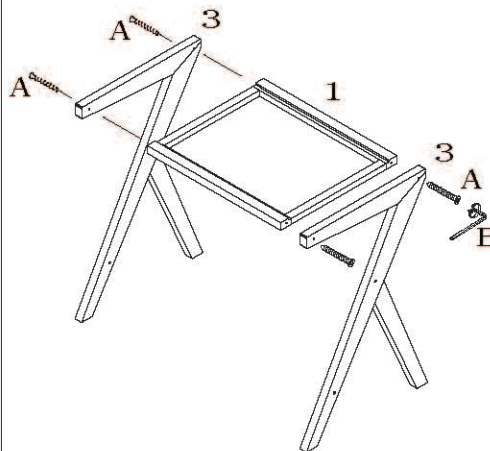

- ② 如图用五金A把部件5固定在部件4上。
Fix component 5 onto component 4 using hardware A.

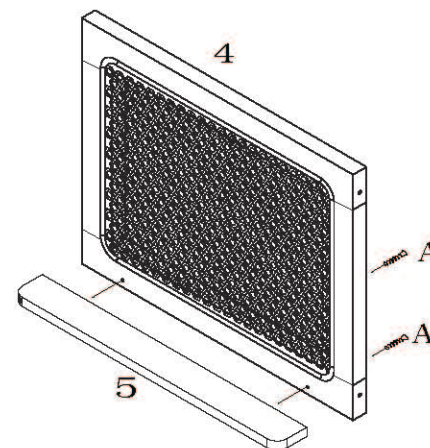

- ③ 先用五金A把部件3/4组装好。再如图将五金B如图位置粘贴好，再把部件2按箭头方向放好。组装完成。
First, assemble component 3/4 with hardware A, then paste hardware B according to the position shown in the diagram, and finally place component 2 in the direction of the arrow. Assembly completed.

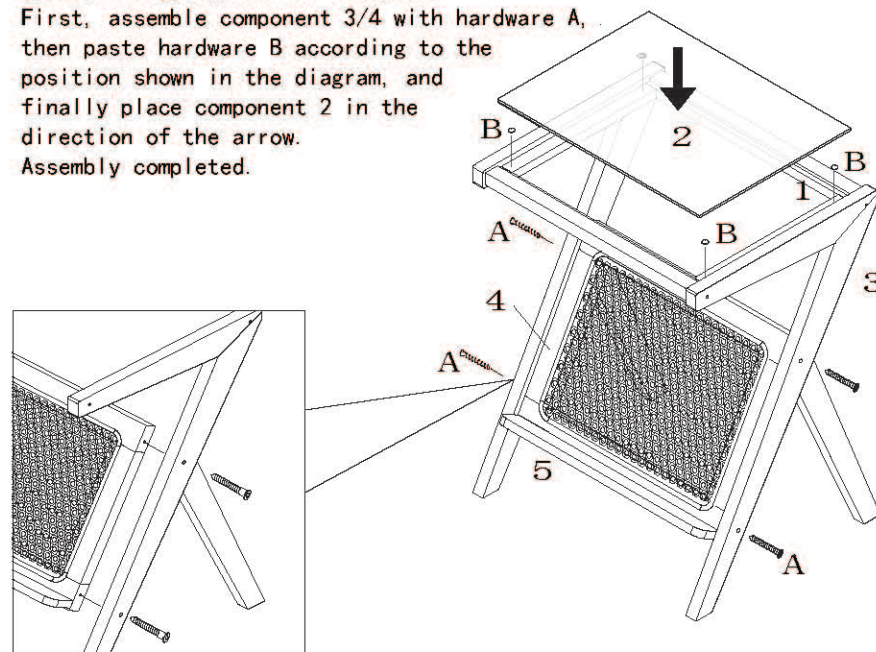

LINSY 林氏家居

安装示意图 / Assembly Instruction

产品名称 Model NO.	LS857J1-A Z字造型边几 LS857J1-A (Z-shaped table)	产品规格 Specification	442*360*565mm
-------------------	--	-----------------------	---------------

安装工具 / Tool



安装人员 / Installer



部件表 / Parts list

编号 NO.	名称 Name	规格 Specification	数量 QTY	材质 Material
1	桌面 desktop	402*350*20	1	竹 bamboo
2	玻璃 glass	400*300*5	1	玻璃 glass
3	侧片 Sidepiece	360*565*20	2	竹 bamboo
4	背板 backboard	402*315*20	1	竹+PVC藤编 bamboo+rattan weaving
5	拉档 cross rail	400*45*12	1	竹 bamboo

五金表 / Hardware list

编号 NO.	名称 Name	图示 Illustration	数量 QTY	材质 Material
A	内六角过山丝 internal hexagonal screw	M5*40	10	镀锌 nickeling
B	硅胶垫 silicone pad		4	硅胶 silica gel
C	内六角扳手 hexagon bar wrench	3#	1	镀锌 nickeling

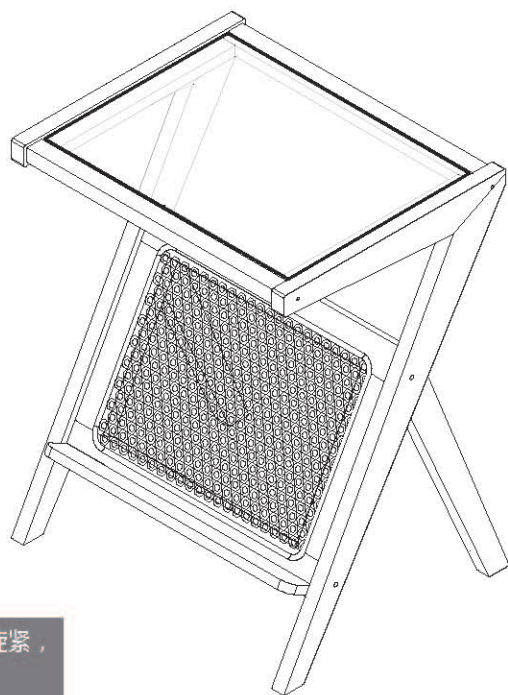

当心夹手 / Watch Your Hand

安装时请勿将手伸入缝中，以防夹手。

Do not reach into the gap during installation to prevent getting fingers pinched.

温馨提示：

步骤中，拉开或安装过程中卡住时，请勿使用蛮力拉开，以免造成产品损坏。

Do not use brute force to pull apart or install when get stuck to avoid product damage.

※ 亲 请您在安装时注意每个五金不要一次性旋紧，需等所有的五金组装到位再固定旋紧。

Please level it and tighten it once

安装步骤 Installation steps

① 如图先把五金A固定好部件1与3。
As shown in the figure, first fix hardware A to component 1/3.

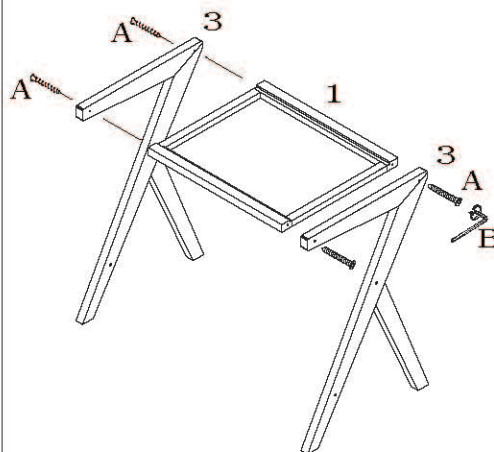

② 如图用五金A把部件5固定在部件4上。
Fix component 5 onto component 4 using hardware A.

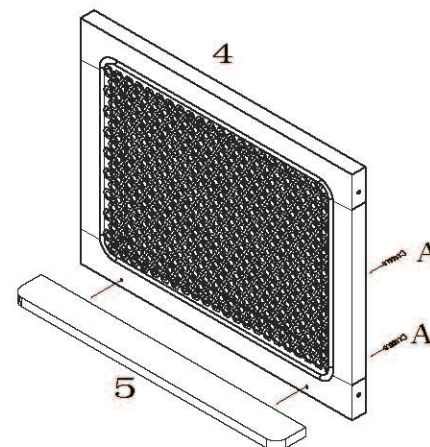

③ 先用五金A把部件3/4组装好。再如图将五金B如图位置粘贴好，再把部件2按箭头方向放好。组装完成。
First, assemble component 3/4 with hardware A, then paste hardware B according to the position shown in the diagram, and finally place component 2 in the direction of the arrow. Assembly completed.

