

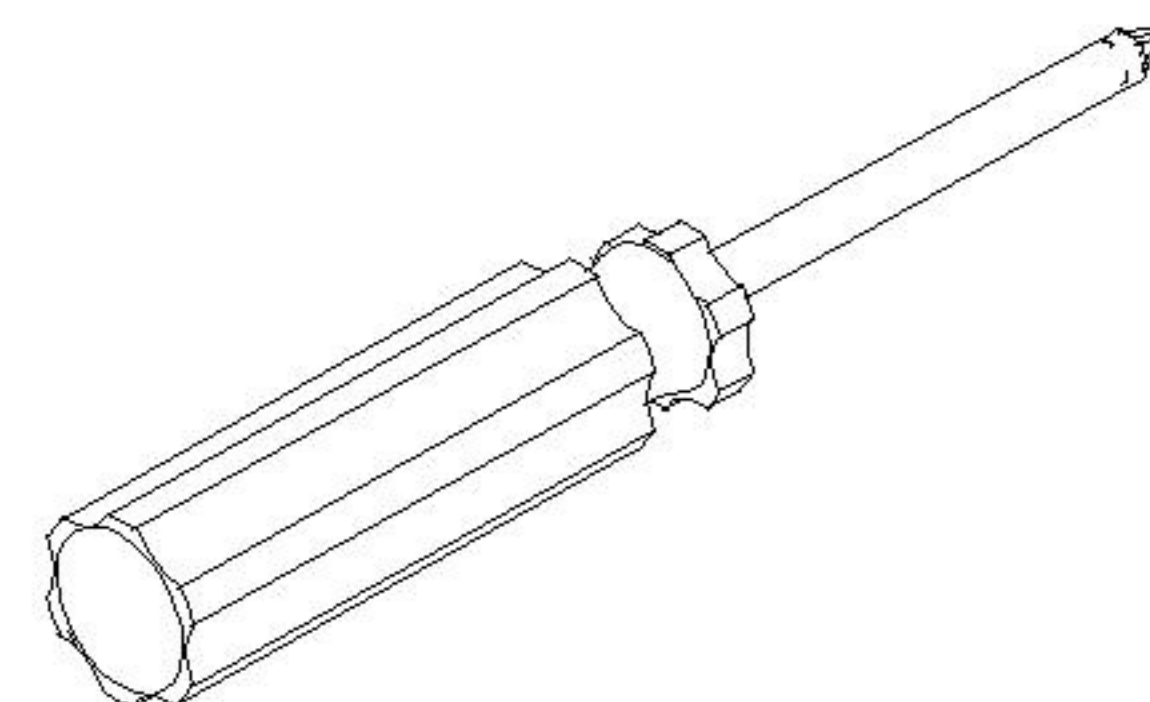

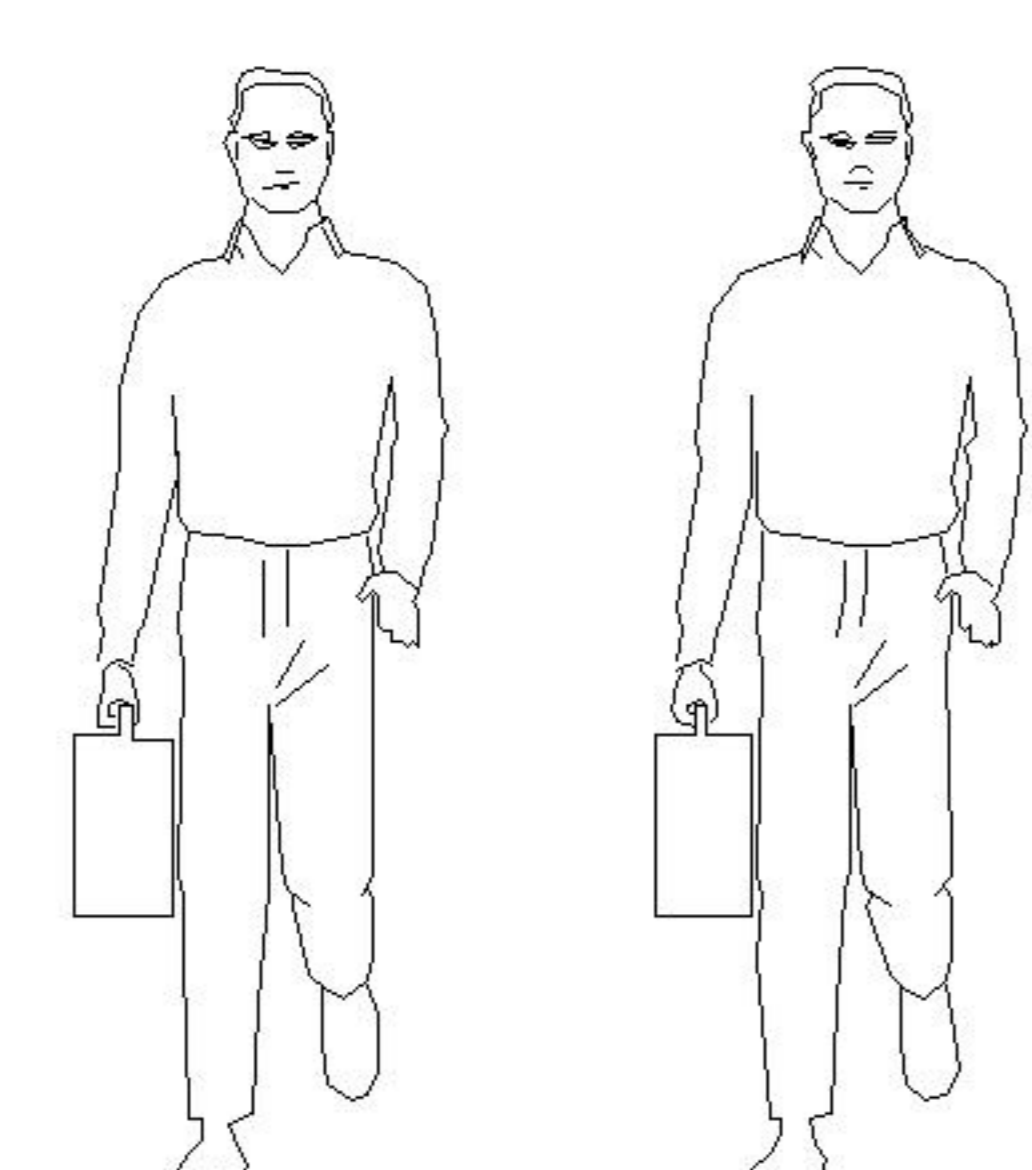

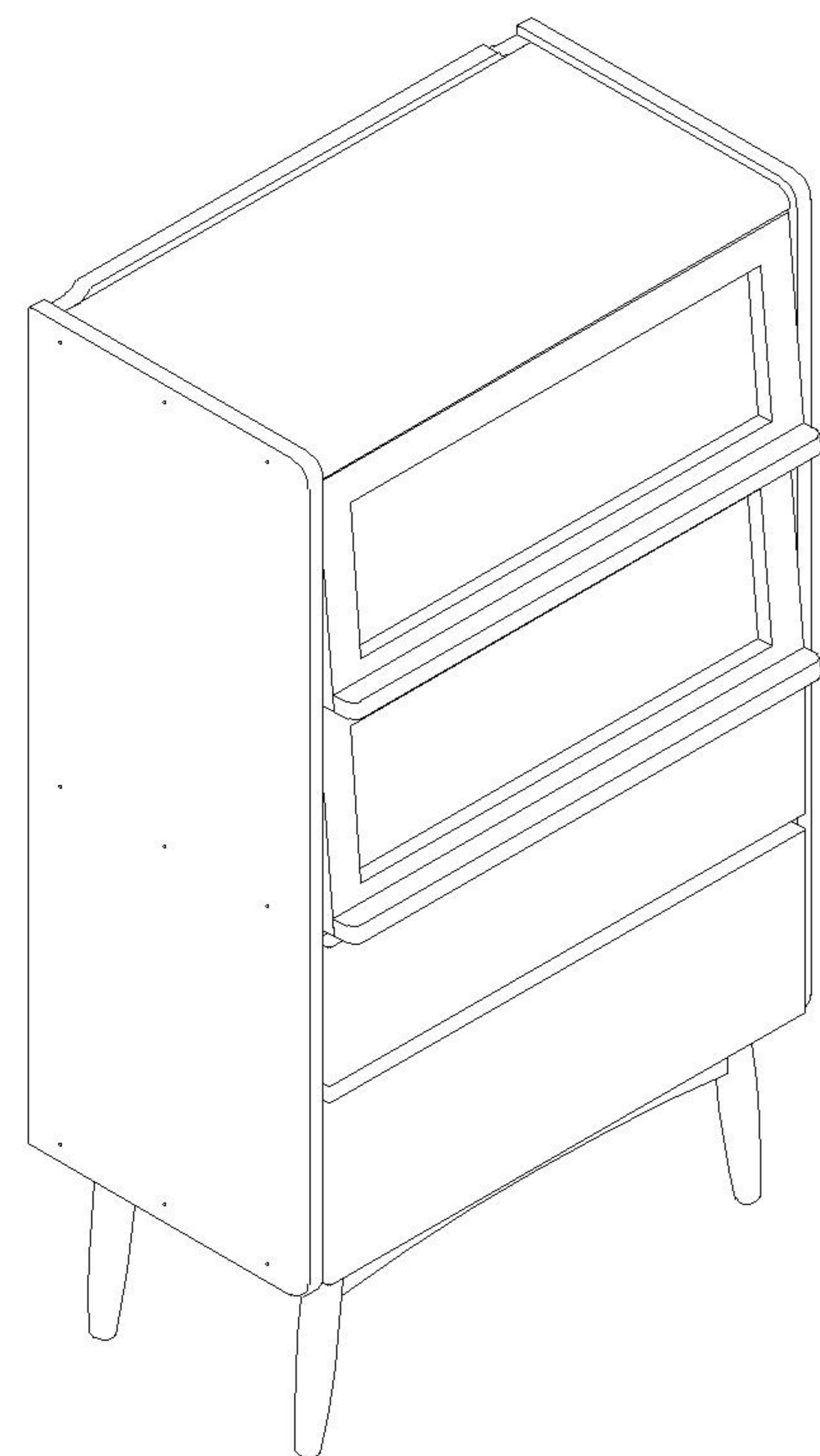

安装示意图/Assembly Instruction

产品名称 Model NO.	RQ10-A
产品规格 Specification	700*428*1212mm
安装工具 Tool	安装人数 Installer
	

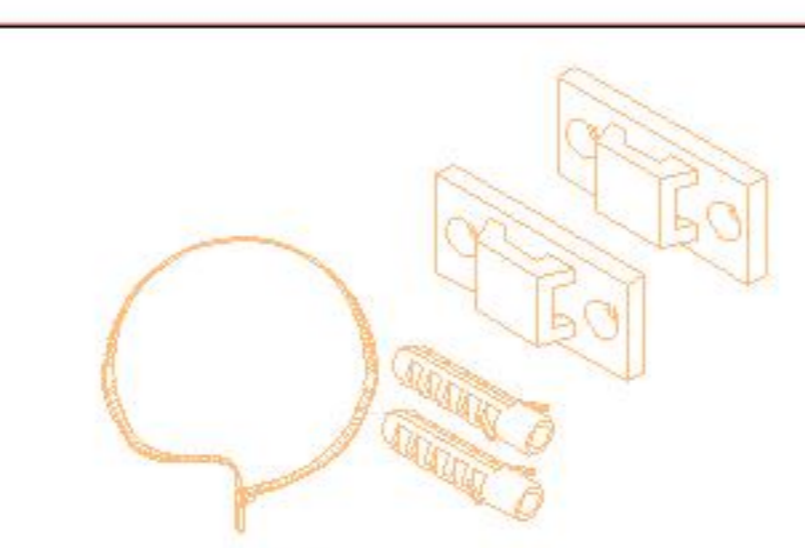
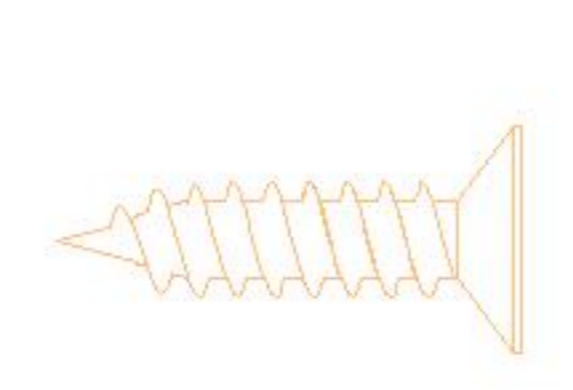
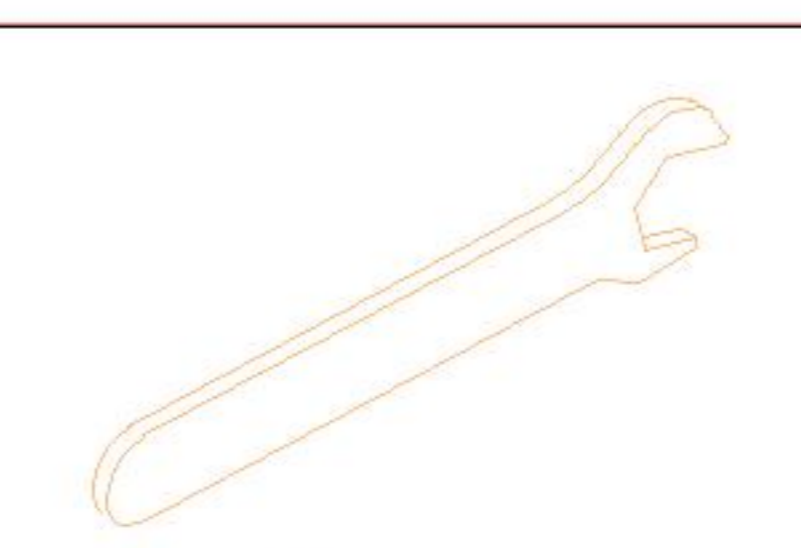
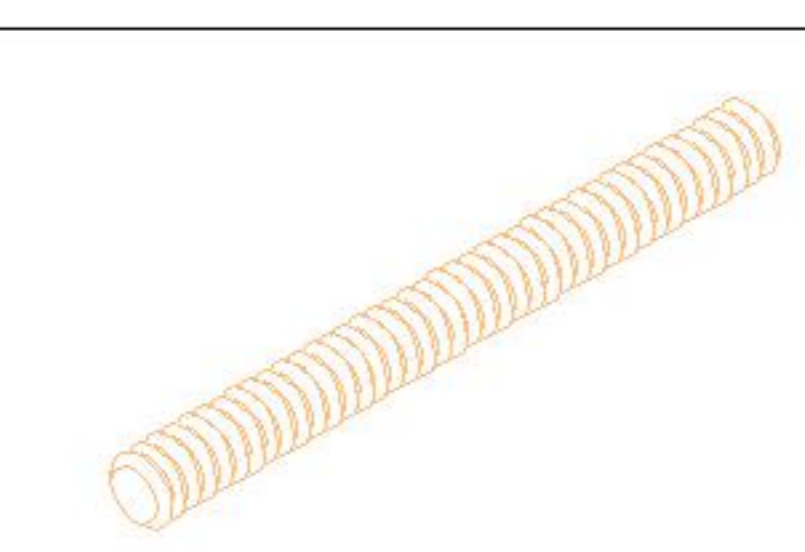
注：为保证设计效果，部分尺寸为定制尺寸，不影响使用。

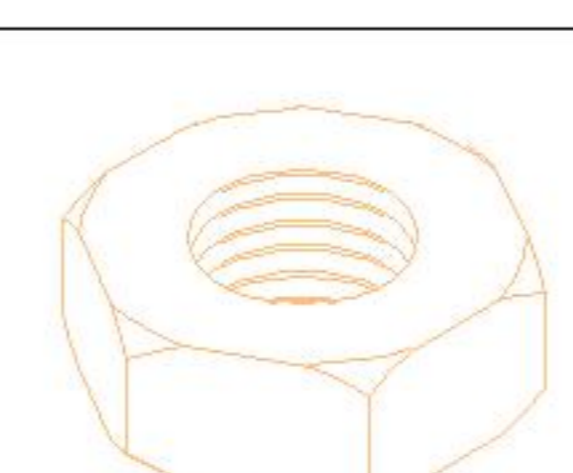
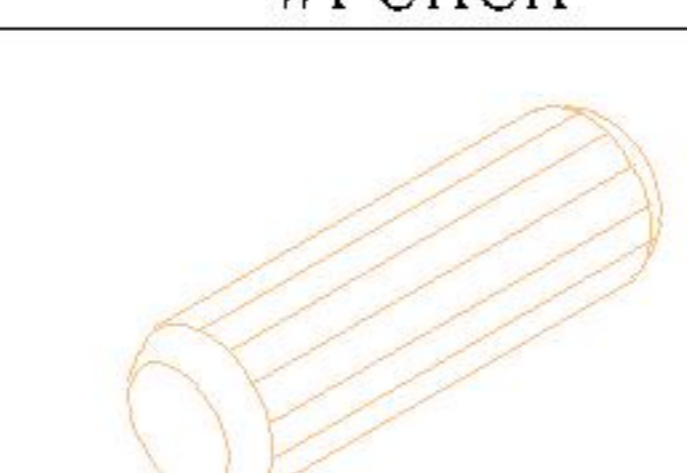

 (A)* 4 脚垫-灰色 Footrest - Grey	 (B)* 2 家具防倒器-白色 Anti-fall device white	 (C)* 4 自攻螺丝M4x45mm Self-tapping screw	 (D)* 1 开口扳手10mm Wrench- Open End Wrench
 (E)* 4 全牙螺杆-M6x70 screw- color zinc	 (F)* 4 开口挡块 Opening screw	 (G)* 4 外六角螺母M6 Hexagon Nut colored zinc	 (H)* 2 木榫06x30mm wood tenon
 (I)* 4 层板托 Layer board support			

编号NO.	名称Name	规格(MM) Specification	数量QTY	材质Material
①	整装柜子Packaged cabinet	700*400*1010	1	黑胡桃木+桐木 Black walnut wood+paulownia
②	门板组立Door plank assembly	656*261*45	2	黑胡桃木+玻璃 Black walnut wood+Glass
③	上抽屉面板Upper drawer's panel	664*168*20	1	黑胡桃木 Black walnut wood
④	上抽盒Up draw box	624*310*110	1	桐木 paulownia
⑤	下抽屉面板Bottom drawer's panel	664*220*20	1	黑胡桃木 Black walnut wood
⑥	下抽盒Lower draw box	624*310*142	1	桐木 paulownia
⑦	前后脚框Front and rear footframes	627*210*61	2	黑胡桃木 Black walnut wood
⑧	侧立水Side apron	216*56*20	2	黑胡桃木 Black walnut wood
⑨	左背板back board(L)	946*332*9	1	桐木 paulownia
⑩	右背板back board(R)	946*332*9	1	桐木 paulownia

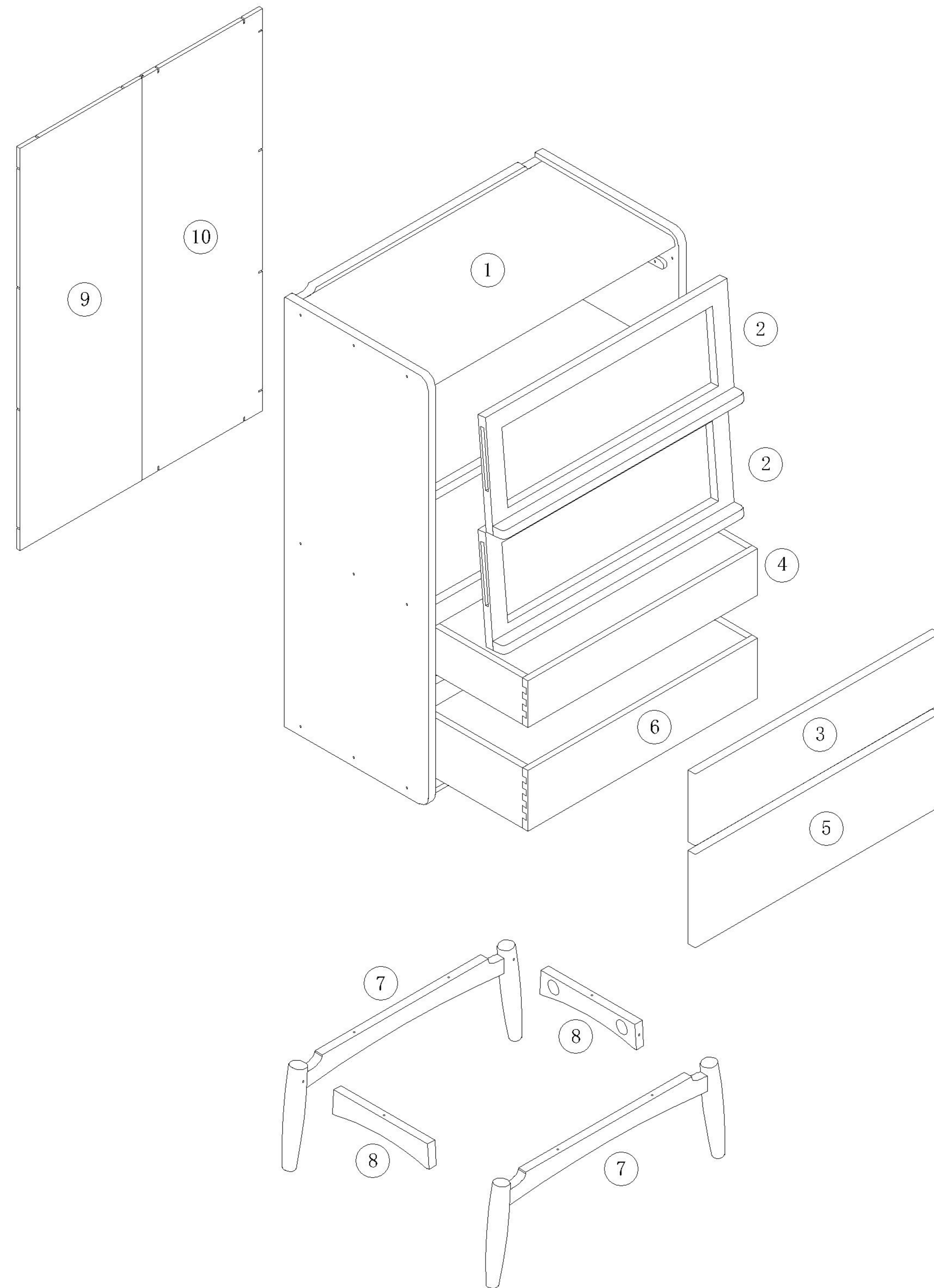

编号NO.	名称Name
①	整装柜子Packaged cabinet
②	门板组立Door plank assembly
③	上抽屉面板Upper drawer's panel
④	上抽盒Up draw box
⑤	下抽屉面板Bottom drawer's panel
⑥	下抽盒Lower draw box
⑦	前后脚框Front and rear footframes
⑧	侧立水Side apron
⑨	左背板back board(L)
⑩	右背板back board(R)

RQ10-A

安装方法/
Installation method

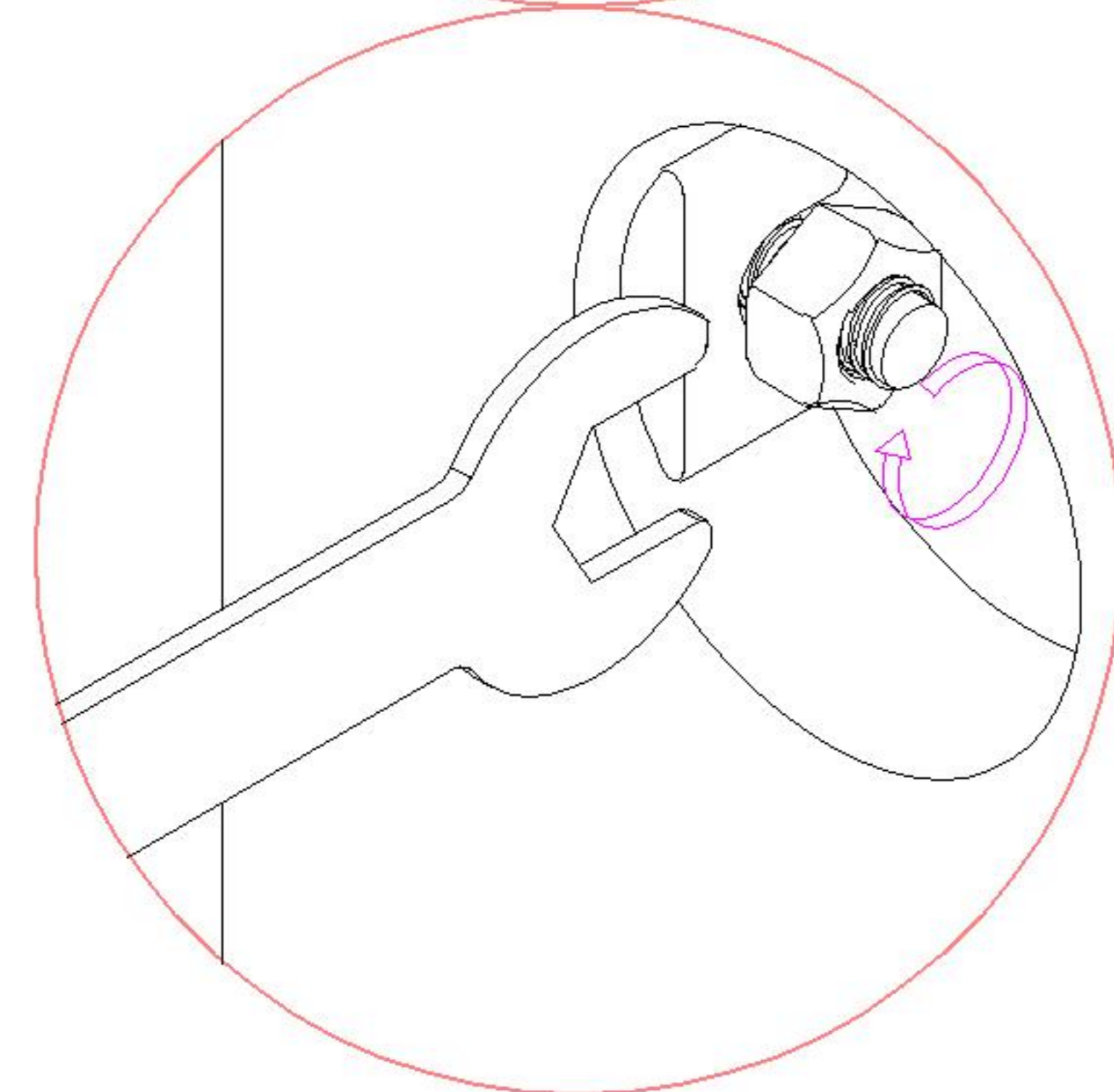
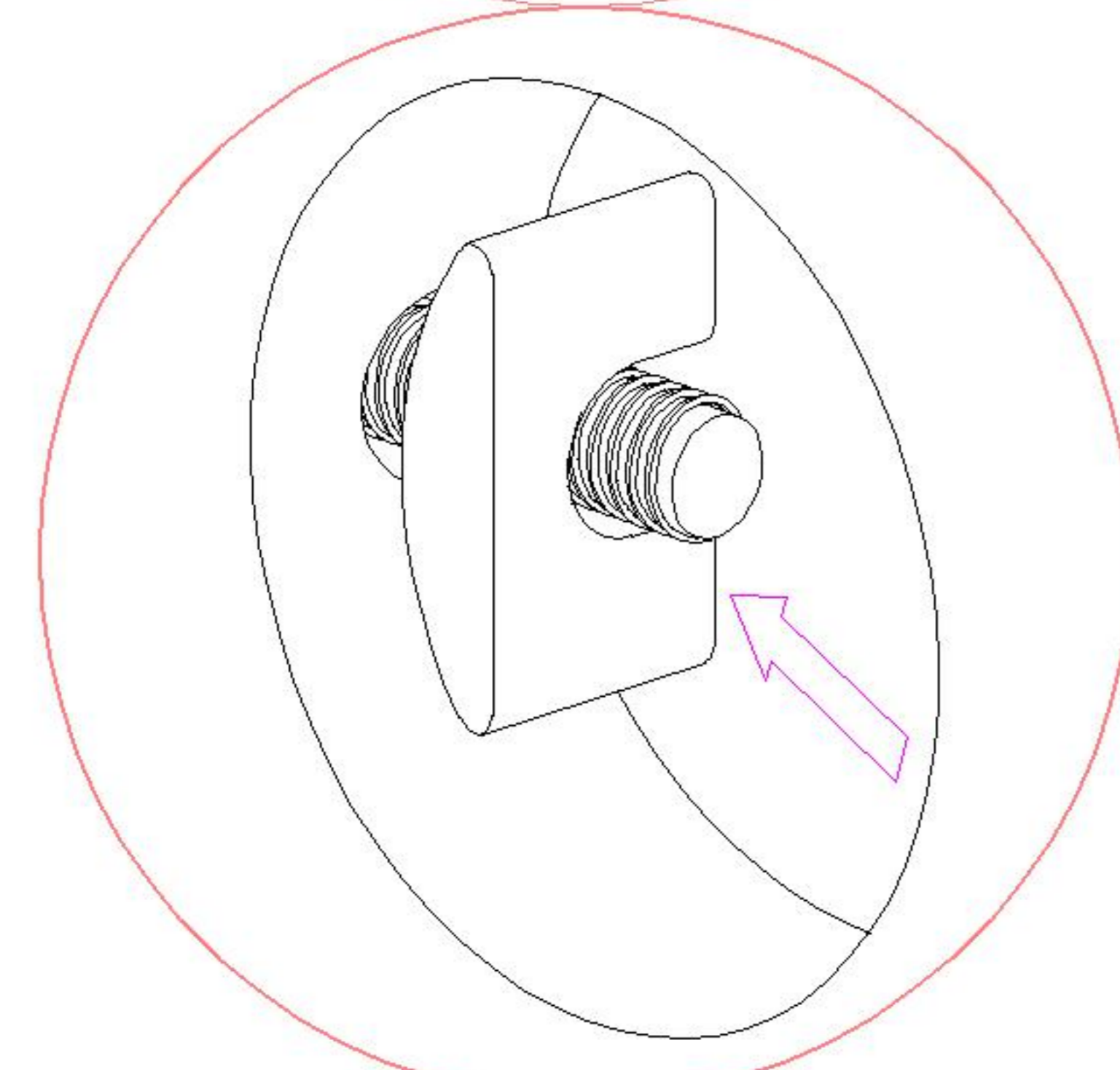
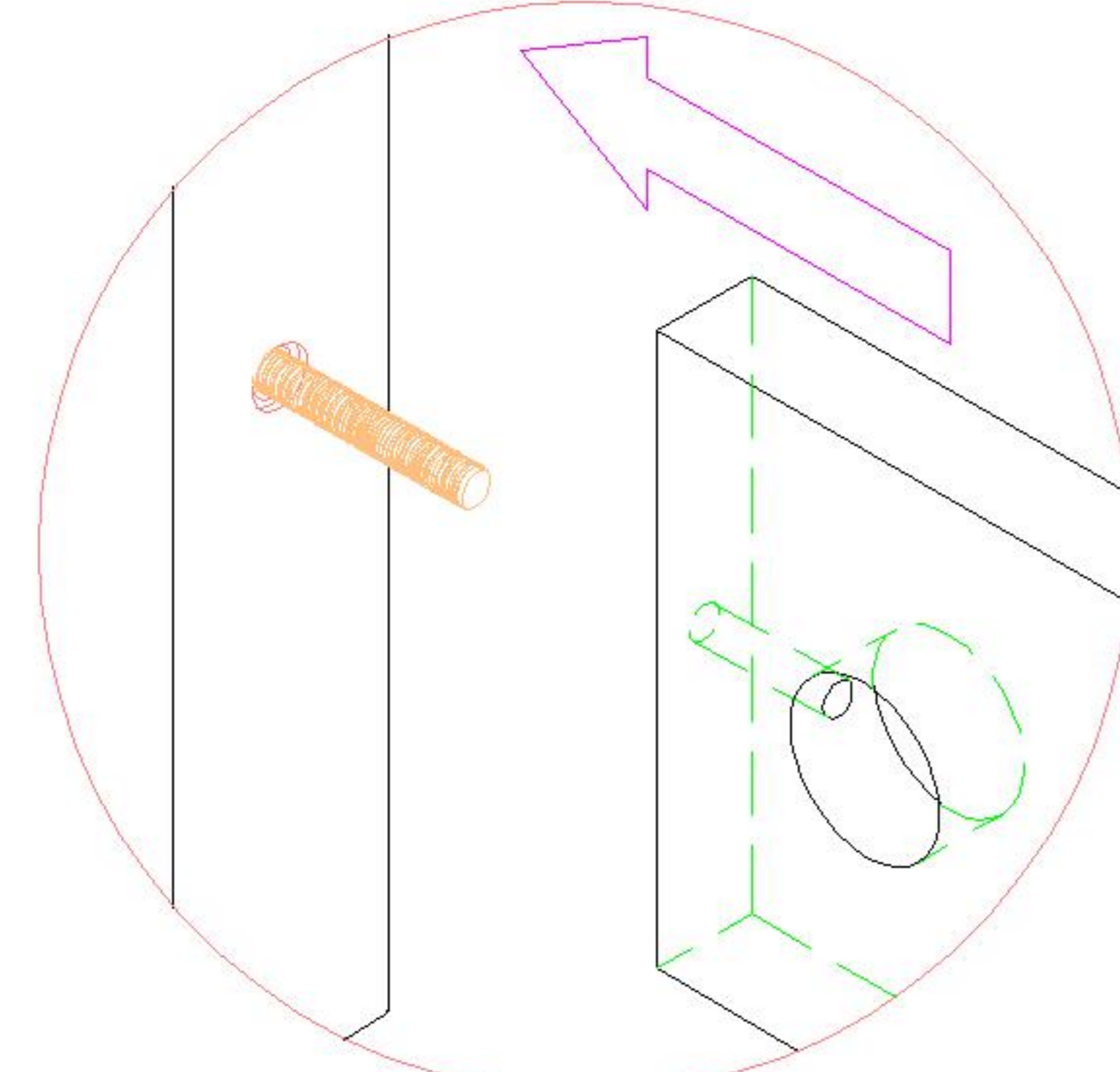
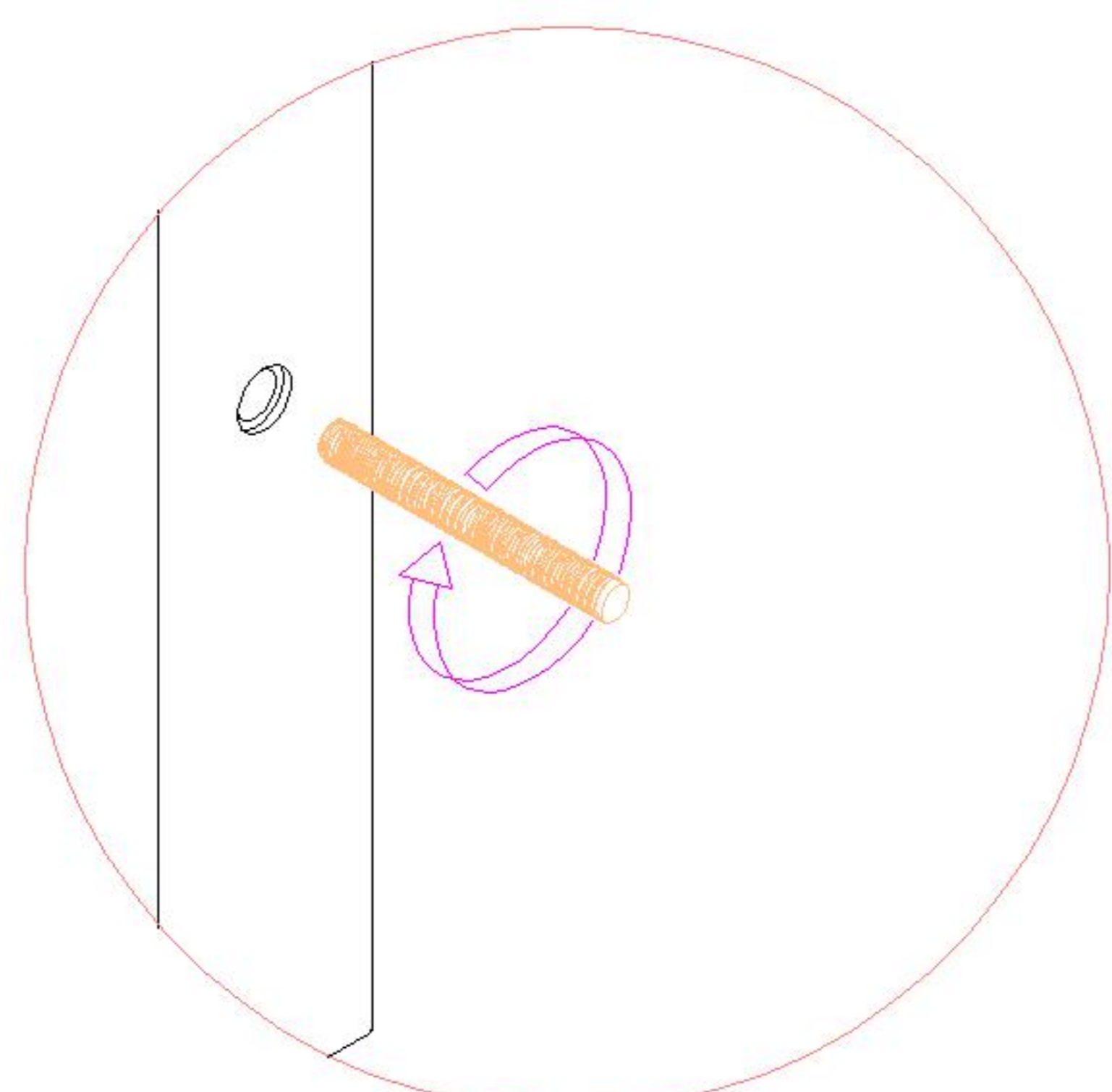

小五合一



(G)*4



(D)*1



(E)*4



(F)*4



(A)*4



(B)*1

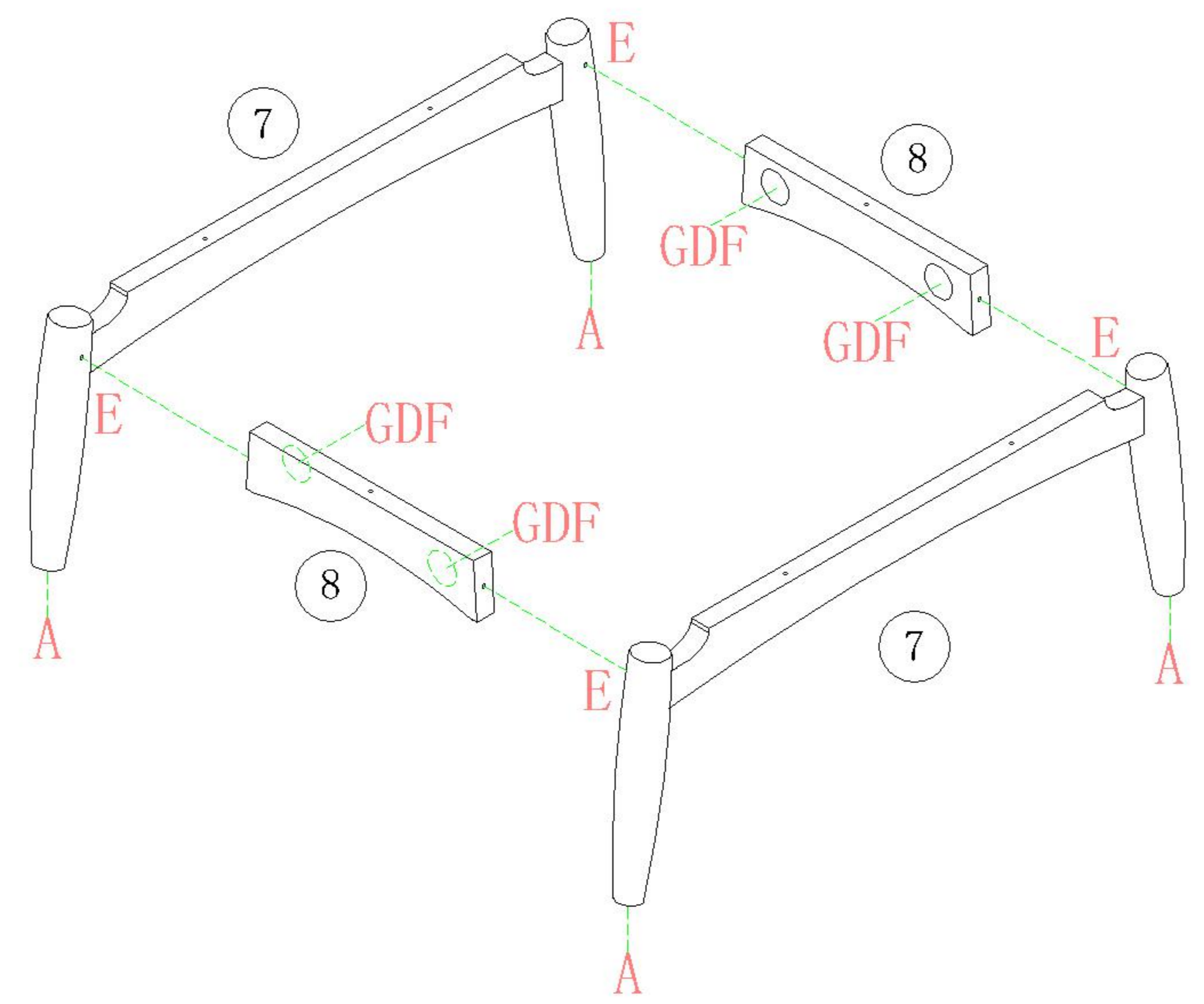

1



(H)*2

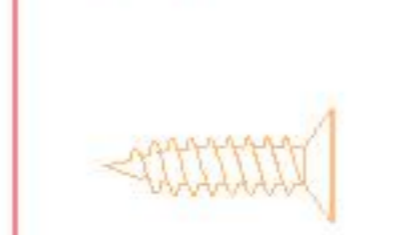

(C)*4

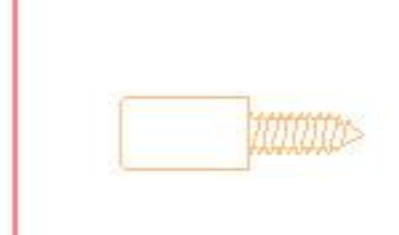

(I)*4

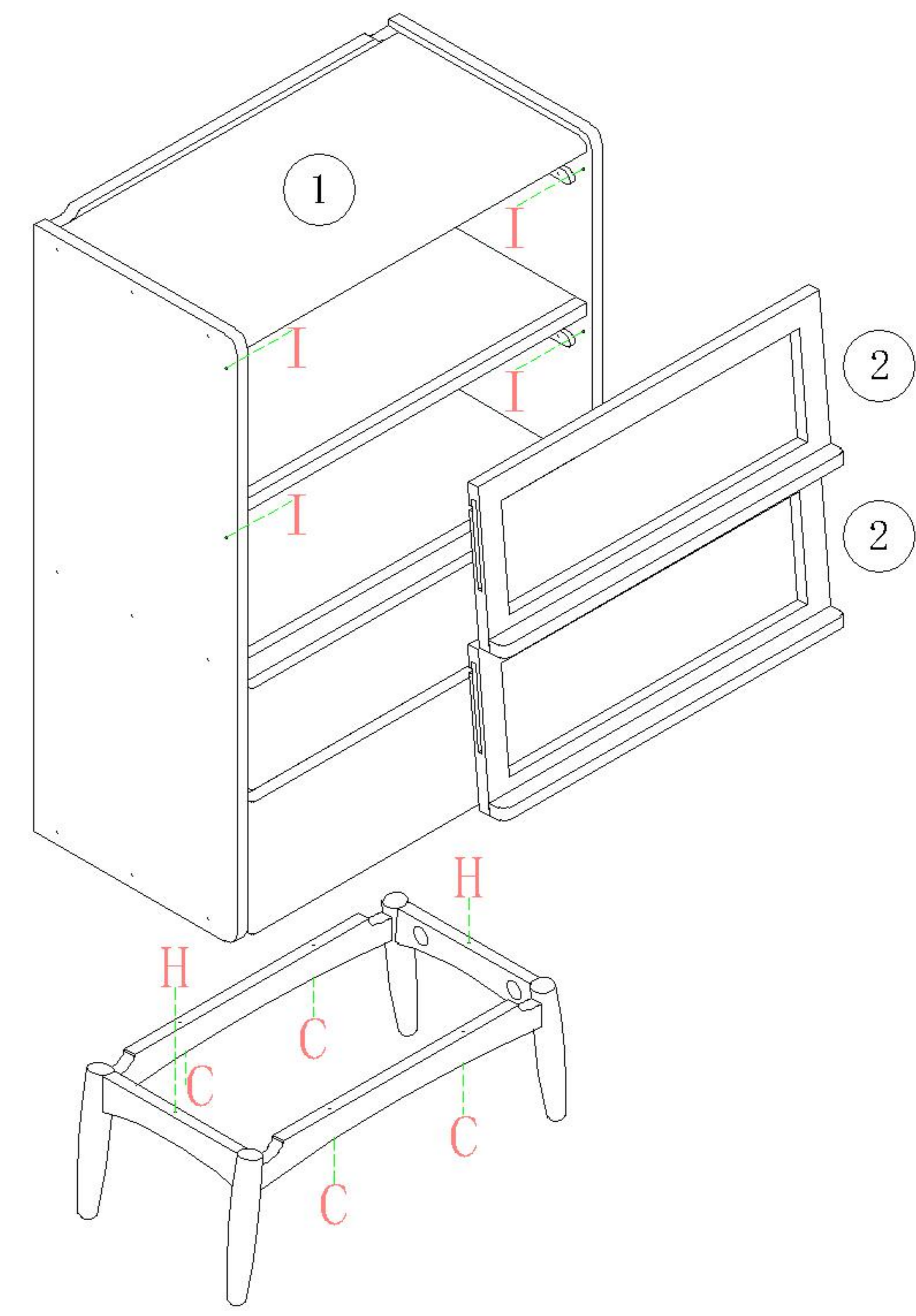

2

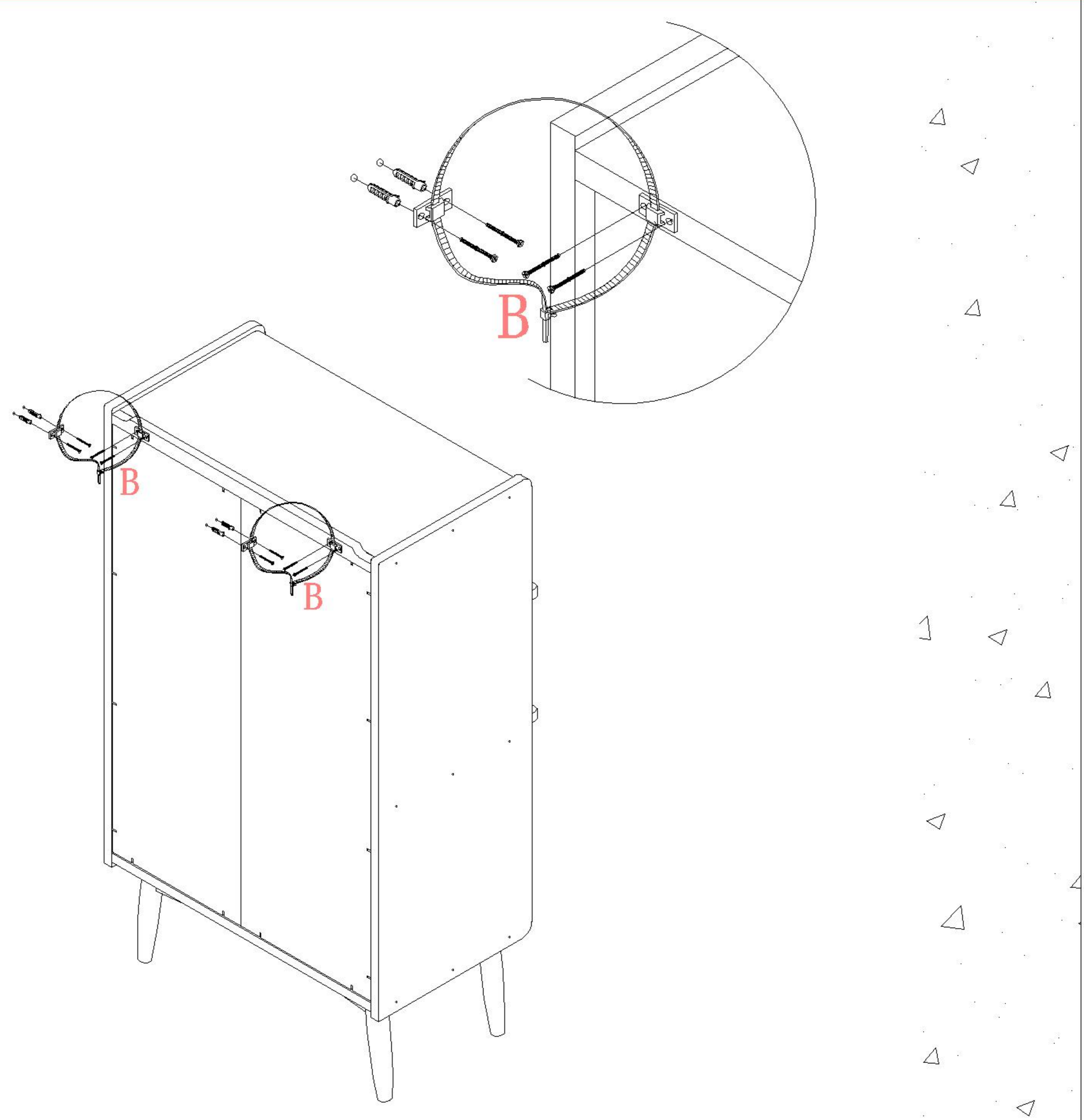
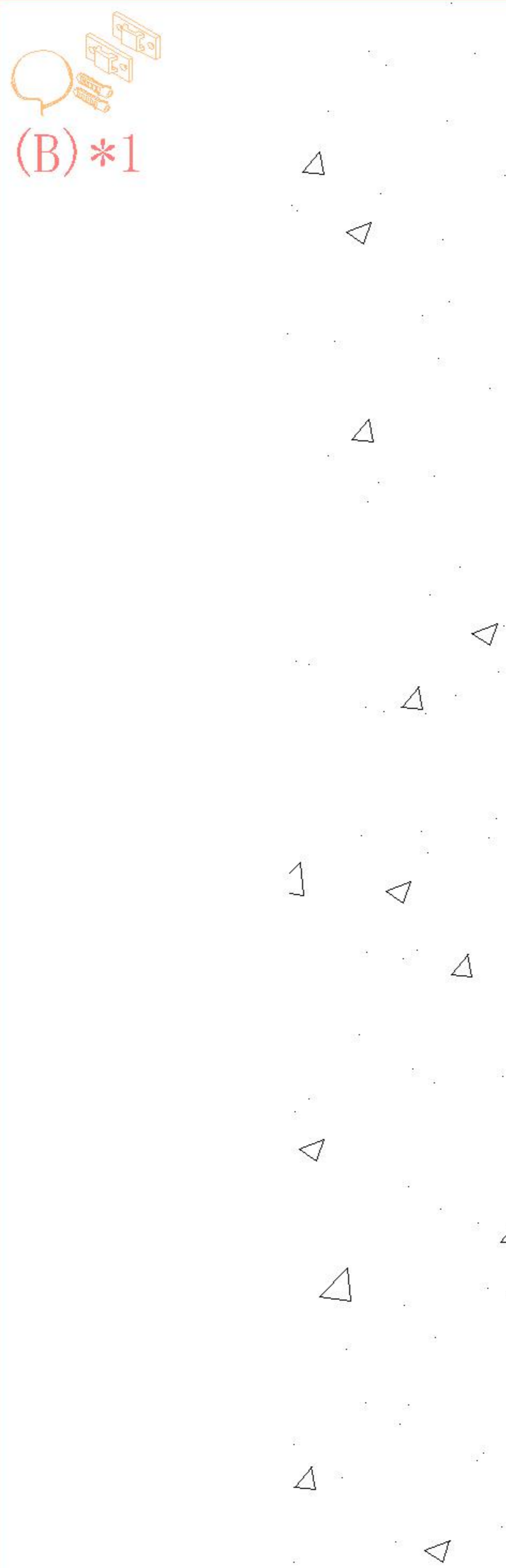

3

